

Synchrotron Spectrum the “Engineering Way”

- Feed electric field of the synchrotron radiation into waveguide
- Mix it with THz-frequency and analyse with spectrum analyser
- => 1 Hz resolution, 40 GHz bandwidth, center frequency adjustable

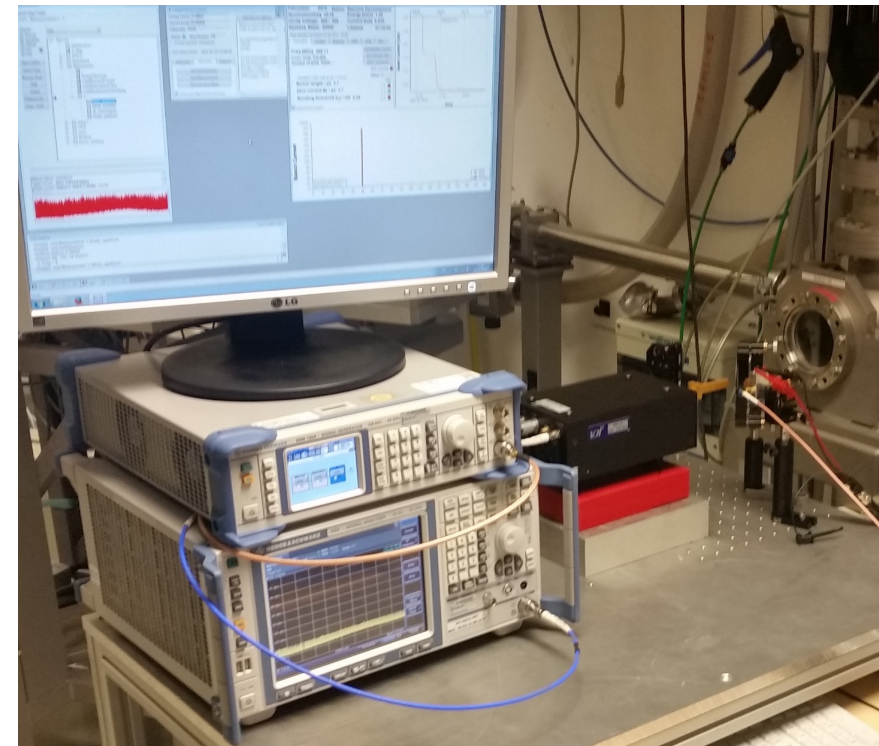
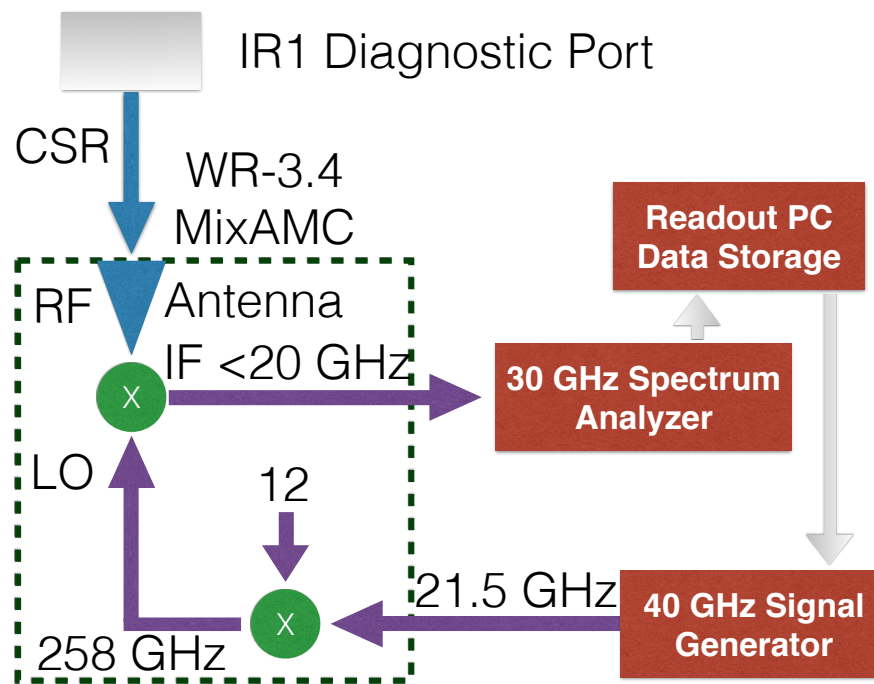

Observed discrete nature of SR at THz frequencies

Revolution frequency comb

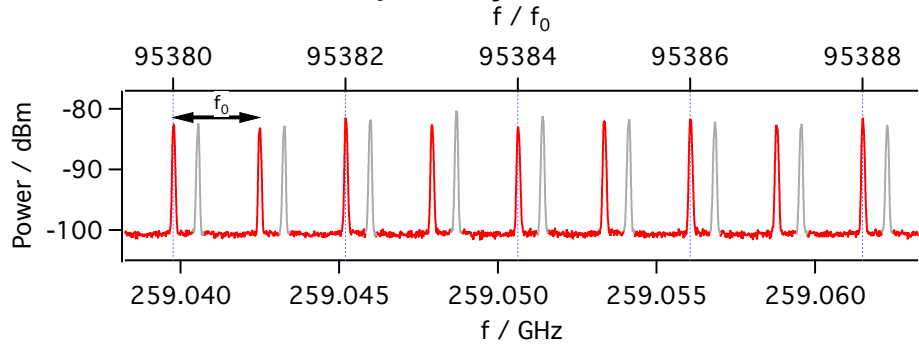

Synchrotron frequency sidebands

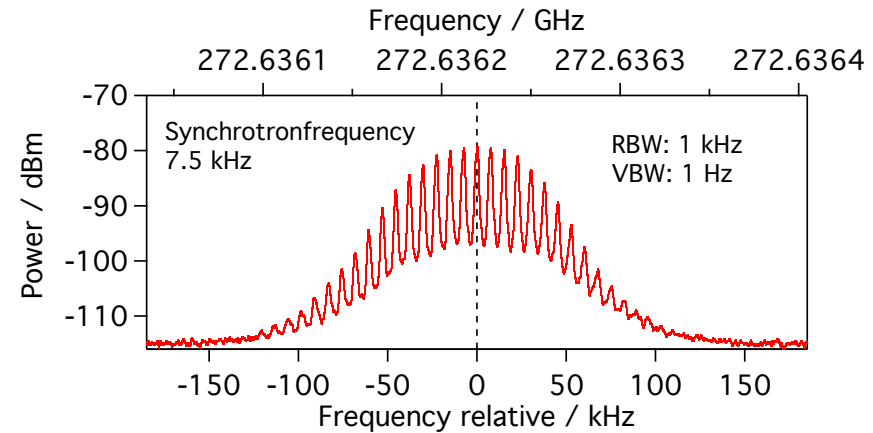

Filling pattern influence

