



DESY Photon Science Users' Meeting 2020 European XFEL Users' Meeting 2020

Jointly organized Users' Meeting of
DESY Photon Science and European XFEL



**14th INTERNATIONAL CONFERENCE ON
SYNCHROTRON RADIATION INSTRUMENTATION**

SRI2021

30 August - 3 September 2021
CCH - Congress Center Hamburg





DESY Photon Science Users' Meeting 2020
European XFEL Users' Meeting 2020
in Hamburg, Germany
DESY Auditorium (Bldg. 5)



Monday, 27 January: Satellite Workshops

09:15 – 19:00	Static Pressure Experiments at XFEL	DESY SemR FLASH, Bldg. 28c
13:30 – 18:30	MID Workshop: First year of operation and future developments	European XFEL XHQ E1.173
13:30 – 18:30	First experiments with a high-intensity short-pulse laser at HED/HIBEF	European XFEL XTOB 1.01

Tuesday, 28 January: Satellite Workshops

08:30 – 20:00	Static Pressure Experiments at XFEL	DESY SemR FLASH, Bldg. 28c
09:30 – 13:00	MID Workshop: First year of operation and future developments	European XFEL XHQ E1.173
09:30 – 12:00	First experiments with a high-intensity short-pulse laser at HED/HIBEF	European XFEL XTOB 1.01
14:00 – 15:40	User experience of data analysis at European XFEL	DESY CSSB Lecture hall, Bldg. 15
09:00 – 18:30	Chemical Dynamics Opportunities at the FXE Instrument	DESY CFEL SemR I-III, Bldg. 99
13:00 - 19:00	Current status and future completion at the HED instrument and the HIBEF contributions	European XFEL XHQ E1.173

Wednesday, 29 January: European XFEL Users' meeting - Plenary Sessions

8:30–10:00 Registration

10:15	Welcome	R. Feidenhans'l	<i>EuXFEL</i>
10:25	Opening address from the Council Chair	M. Faury	<i>CEA Saclay</i>
	European XFEL Update Session		Chairperson: M. Faury (CEA)
10:35	General status of the project	R. Feidenhans'l	<i>EuXFEL</i>
11:10	Electron accelerator – status and further goals	W. Decking	<i>DESY Hamburg</i>
11:45	Requirements and ideas to reduce experiment data at EuXFEL	S. Aplin	<i>EuXFEL</i>
12:20	News from the European XFEL User Organization	A. Eschenlohr	<i>U Duisburg-Essen</i>

12:40–14:00 Lunch break

Science Session

Chairperson: O. Alekseeva (RAS)

14:00	Membrane protein MHz crystallography at the European XFEL	N. Zatsepin	<i>La Trobe</i>
14:30	Coulomb explosion imaging as structural probe of polyatomic molecules	R. Boll	<i>EuXFEL</i>
15:00	Insights into the donor-acceptor properties of base metal free dyads for photocatalysis	M. Bauer	<i>U Paderborn</i>
15:30	MHz X-ray Microscopy at Synchrotron and FEL Facilities	P. Vagovic	<i>DESY/EuXFEL</i>

16:00-16:30 Coffee break

Chairperson: M. Harmand (IMPMC)

16:30	Nucleation dynamics of skyrmion lattice from magnetic fluctuations phase	B. Pfau	<i>MBI Berlin</i>
17:00	Femto-second holographic X-ray imaging with FEL pulses of laser-induced cavitation bubbles	T. Salditt	<i>Uni. Göttingen</i>
17:30	Static high pressure experiments at European XFEL	S. McWilliams	<i>CSEC Edinburgh</i>
18:00	Elastic and inelastic X-ray scattering from isochorically heated carbon	D. Kraus	<i>HZDR</i>

19:00 European XFEL Dinner Reception (in the DESY canteen, Bldg. 9)

Thursday, 30 January: DESY Photon Science Users' Meeting - FLASH

8:30–9:00 Registration

Chairperson: E. Plönjes (DESY)

09:00	Welcome	H. Franz	DESY Hamburg
09:05	FLASH - today and tomorrow - status report and future plans	M. Beye	DESY Hamburg
09:30	THz/XUV pump-probe experiments for studying local fields and dynamics at surfaces	J. Osterwalder	University of Zurich
10:00	Distorting atoms – The nonlinear driving of atom-specific transitions with intense XUV light	C. Ott	MPI-K Heidelberg

10:30 - 11:00 Coffee break

Science Session: Soft X-ray FEL Science Highlights (jointly organised)

Chairperson: S. Molodtsov (EuXFEL)

11:00	X-ray Lasers Shed Light on the Mysteries of Water	A. Nilsson	U Stockholm
11:30	Imaging nanostructures in superfluid helium droplets	R. Tanyag	MBI Berlin
12:00	Evidence of Extreme Ultraviolet Superfluorescence in Xenon	L. Mercadier	EuXFEL
12:30	Transient magnetic scattering in thin Co/Pt multilayers upon femtosecond IR excitation	I. Pronin	University ITMO St. Petersburg
13:00	ESUO report	U. Pietsch (ESUO Chair)	Univ. Siegen

13.10 - 14.00 Lunch break

Satellite workshops

13:00 - 18:25	10th workshop on X-ray Nano-Imaging of Biological and Chemical Systems at PETRA III	DESY CFEL I-III, Bldg. 99
13:00–18:25	Coherent X-ray scattering and imaging	DESY CFEL I-III, Bldg. 99 & SemR FLASH, Bldg. 28c
13:00–18:20	SAXS/WAXS/GISAXS User Workshop @ DESY	DESY CSSB Lecture hall, Bldg. 15
14:00–19:00	High-pressure Science in the Large Volume Press at Beamline P61B	DESY SemR 456, Bldg. 25f
14:00–18:40	Central infrastructure for DESY Photon Science Scientific computing - update and future directions	DESY SemR. BAH1/BAH2, Bldg. 3
13:00–18:20	X-ray absorption spectroscopy at P64/65	DESY SemR 4ab, Bldg. 1b
14:00–18:00	High Energy X-Ray Diffraction for Physics and Chemistry	DESY CFEL SemR IV, Bldg. 99
14:00–18:00	Light-Matter Interaction: Recent Advances in Theory	DESY CFEL SemR V, Bldg. 99
14:00–18:00	ECB Workshop (Extreme Conditions Beamline P02.2)	DESY SemR 3, Bldg. 1b
14:00–18:30	Interfaces in electrochemistry, corrosion and solution based self assembly	DESY SemR 109, Bldg. 25b
14:00–18:00	High Energy X-Rays for Swedish Materials Science	DESY O1.030, Bldg. 48f
14:00–19:10	First meeting of the European XFEL Spanish user community	DESY EMBL SemR, Bldg. 48e
14:00–18:00	Helmholtz-Zentrum Geesthacht GEMS Outstation: Materials Research and High Resolution Imaging	DESY DESY Auditorium, Bldg. 5
14:00–18:00	Best of Science for new Therapies (on invitation)	DESY SemR 1, Bldg. 1

19:00 DESY Reception for speakers and participants
Supported by industry exhibition

(in the DESY canteen, Bldg. 9)

Friday, January 31: DESY Photon Science Users' Meeting

8:30 – 9:00 Registration

Chairperson: G. Grübel (DESY)

09:00	Welcome and news from LEAPS	H. Dosch	DESY, Hamburg
09:10	Photon Science at DESY	E. Weckert	DESY, Hamburg
09:50	PETRA III and future outlook - PETRA IV	C. Schroer	DESY/Univ. Hamburg

10:20 - 10:50 Coffee break

Chairperson: H.-C. Wille (DESY)

10:50	Structural insights into the multifunctional L protein of bunyaviruses	M. Rosenthal	BNI Hamburg
11:20	Size Induced Structural Changes in Molybdenum Oxide Nanoparticles	T. L. Christiansen	Univ. Kopenhagen
11:50	Investigating Amphiphilic Monolayers with Grazing-Incidence Diffraction and X-ray Fluorescence	E. Schneck	TU Darmstadt
12:20	Direct imaging of orbitals in quantum materials using inelastic X-ray scattering	L. H. Tjeng	MPI Dresden
12:50	Report of the DESY Photon Science User Committee (DPS-UC) Results DPS-UC Election 2020	P. Müller-Buschbaum (DPS-UC Chair)	TU München
13:00	Report of the ‚Komitee Forschung mit SR‘ (KFS)	B. Murphy (KFS Chair)	University Kiel

13.10 - 14:00 Lunch break

14:00-17:00 POSTER SESSION (14-17h) and Vendor exhibition (10-18h)

Venue: "Kuppel Hamburg"

(dome on the Trabrennbahn Bahrenfeld, opposite to the campus - Luruper Chausse 30)

DESY Photon Science User Committee

Election 2020

Please vote **X** online until

Thursday 30 January, 14:00 h

DOOR.desy.de

General Information

Oral and poster sessions

The oral sessions will be held in the DESY auditorium (bldg. 5).

The poster session on Friday afternoon will take place in the dome 'Kuppel Hamburg'.

The 'Kuppel Hamburg' is located on the Trabrennbahn Hamburg, outside of the DESY campus near the side gate: Luruper Chaussee 30, 22761 Hamburg (see map).

Vendor exhibition

The vendor exhibition will take place in the 'Kuppel Hamburg' on Friday, 31 January from 10 - 18h.

Social events

The European XFEL reception

Wednesday, 29 January, at 19:00 in the DESY canteen (bldg. 9).

The DESY Photon Science reception

Thursday, 30 January, at 19:00 in the DESY canteen (bldg. 9).

DESY WLAN

Name: UsersMeeting2020

WPA/WPA2-PSK: Ee7foi9koht4



Organisers

S. Bertini (European XFEL), K. Baranašić (European XFEL), G. Heeßel (European XFEL), M. Kreuzeder (DESY), K. Kucza (DESY), W. Laasch (DESY), F. Lehmkuhler (DESY), S. Molodtsov (European XFEL), G. Quondam (European XFEL), A. Rothkirch (DESY), D. Unger (DESY)

Local Information

Cash machine/ATM

You will find a cash machine in the foyer of the DESY canteen (bldg. 9).

Meals

Breakfast

If you stay at the DESY guest house you may have breakfast in the DESY cafeteria (opens at 07:00, bldg. 9) or CFEL Cafeteria (opens at 8:00, bldg. 99) at your own expenses.

Lunch

You may have lunch in the DESY canteen (bldg. 9) or CFEL Cafeteria (bldg. 99) at your own expenses.

Shops etc.

Lidl (supermarket)

From the DESY main gate (Notkestrasse) turn right and follow the street (700 – 800m).

Denn's Biomarkt (supermarket)

From the DESY main gate walk straight down the street 'Zum Hünengrab' (700 – 800m). At the end of the street on the right side you will find the supermarket. You will find e.g. a bakery, drugstore and other shops as well as restaurants in the vicinity.

Public transportation

Bus (HVV): Bus stops near the main entrance: 'Zum Hünengrab (DESY)' and near the side entrance: 'Luruper Chaussee (DESY)'. Further information: www.hvv.de

Bike rental (StadtRAD Hamburg): There are two city bike stations on the DESY campus where bikes can be returned. Further information: stadtrad.hamburg.de

On-demand shuttle service (ioki): Stations are available in an area close to DESY and on the campus. Further information (a HVV ticket is needed in addition): www.hvv.de/de/ioki.

I Main sessions
Abstracts of the talks

Membrane protein MHz crystallography at the European XFEL

Chris Gisriel^{1,2,3}, Jesse Coe^{1,2}, Romain Letrun⁴, Oleksandr M. Yefanov⁵, Cesar Luna-Chavez^{1,2}, Natasha E. Stander^{1,2}, Stella Lisova^{1,6}, Valerio Mariani⁵, Manuela Kuhn⁵, Steve Aplin⁵, Thomas D. Grant^{7,8}, Katerina Dörner⁴, Tokushi Sato^{4,5}, Austin Echelmeier^{1,2}, Jorvani Cruz Villarreal^{1,2}, Mark S. Hunter⁹, Max O. Wiedorn^{5,10,11}, Juraj Knoska⁵, Victoria Mazalova⁵, Shatabdi Roy-Chowdhury^{1,2}, Jay-How Yang^{1,2}, Alex Jones^{1,2}, Richard Bean⁴, Johan Bielecki⁴, Yoonhee Kim⁴, Grant Mills⁴, Britta Weinhausen⁴, Jose D. Meza⁴, Nasser Al-Qudami⁴, Saša Bajt¹², Gerrit Brehm^{1,2,13,14}, Sabine Botha⁶, Djelloul Boukhelef⁴, Sandor Brockhauser^{4,15}, Barry D. Bruce^{16,17,18}, Matthew A. Coleman¹⁹, Cyril Danilevski⁴, Erin Discianno¹, Zachary Dobson^{1,2}, Hans Fangohr^{4,20}, Jose M. Martin-Garcia¹, Yaroslav Gevorkov^{8,21}, Steffen Hauf⁴, Ahmad Hosseinizadeh²¹, Friederike Januschek^{4,22}, Gihan K. Ketawala^{1,2}, Christopher Kupitz^{9,21}, Luis Maia⁴, Maurizio Manetti⁴, Marc Messerschmidt^{1,2,4}, Thomas Michelat⁴, Jyotirmoy Mondal¹⁶, Abbas Ourmazd²¹, Gianpietro Previtali⁴, Iosifina Sarrou⁵, Silvan Schön⁵, Peter Schwander²¹, Megan L. Shelby¹⁹, Alessandro Silenzi⁴, Jolanta Sztuk-Dambietz⁴, Janusz Szuba⁴, Monica Turcato⁴, Thomas A. White⁵, Krzysztof Wrona⁴, Chen Xu⁴, Mohamed H. Abdellatif⁵, James D. Zook^{1,2}, John C. H. Spence^{1,6}, Henry N. Chapman^{5,10,11}, Anton Barty⁵, Richard A. Kirian^{1,6}, Matthias Frank¹⁹, Alexandra Ros^{1,2}, Marius Schmidt²¹, Raimund Fromme^{1,2}, Adrian P. Mancuso^{4,24}, Petra Fromme^{1,2} and Nadia A. Zatsepin^{1,6,24}

¹*Biodesign Center for Applied Structural Discovery, Arizona State University, USA*

²*School of Molecular Sciences, Arizona State University, USA*

³*Present address: Department of Chemistry, Yale University, New Haven, USA*

⁴*European XFEL GmbH, Schenefeld, Germany*

⁵*Center for Free-Electron Laser Science, DESY, Hamburg, Germany*

⁶*Department of Physics, Arizona State University, USA*

⁷*Hauptman-Woodward Institute, Buffalo, USA*

⁸*Department of Structural Biology, Jacobs School of Medicine and Biomedical Sciences, SUNY Univ. at Buffalo, USA*

⁹*Linac Coherent Light Source, SLAC National Accelerator Laboratory, USA*

¹⁰*Department of Physics, Universität Hamburg, Hamburg, Germany*

¹¹*CUI, Universität Hamburg, Hamburg, Germany*

¹²*DESY, Hamburg, Germany*

¹³*Institute for X-Ray Physics, University of Göttingen, Göttingen, Germany*

¹⁴*Center Nanoscale Microscopy and Molecular Physiology of the Brain, Göttingen, Germany*

¹⁵*Biological Research Centre, Hungarian Academy of Sciences, Szeged, Hungary*

¹⁶*Department of Biochemistry & Cellular and Molecular Biology, Univ. of Tennessee at Knoxville, USA*

¹⁷*Program in Energy Science and Engineering, University of Tennessee at Knoxville, USA*

¹⁸*Department of Microbiology, University of Tennessee at Knoxville, USA*

¹⁹*Lawrence Livermore National Laboratory, Livermore, USA*

²⁰*University of Southampton, Southampton, UK*

²¹*Department of Physics, University of Wisconsin-Milwaukee, Milwaukee, USA*

²²*Present address: DESY, Hamburg, Germany*

²³*Hamburg University of Technology, Vision Systems E-2, Hamburg, Germany*

²⁴*ARC Centre of Excellence in Advanced Molecular Imaging, Department of Chemistry and Physics, La Trobe Institute for Molecular Science, La Trobe University, Victoria, Australia*

The presentation will focus on the first membrane protein megahertz serial femtosecond crystallography experiment at the SPB/SFX beamline of the European XFEL. We determined a high-resolution structure of the large membrane protein complex involved in photosynthesis, Photosystem I. The talk will cover challenges in megahertz SFX for membrane protein microcrystals, briefly covering batch microcrystallisation and sample delivery for MHz SFX, while focusing on data collection and analysis [1].

[1] Gisriel, C., Coe, J. et al. *Nature Comm.* 10, 5021 (2019) DOI: 10.1038/s41467-019-12955-3

Email of corresponding authors: n.zatsepin@latrobe.edu.au, pfromme@asu.edu

Coulomb explosion imaging as structural probe of polyatomic molecules

Rebecca Boll

European XFEL, SQS Scientific Instrument

Recording images of individual molecules with ultrashort "exposure times" has been a long-standing dream in molecular physics, chemistry, and biology because this would allow one to follow the motion of atoms on their inherent timescale (10^{-15} s). While X-ray and electron diffraction have been successfully used to retrieve the structure of large biomolecules, both are very challenging to apply to small molecules in the gas phase. Moreover, these techniques are essentially blind to hydrogen atoms, which are key to many chemical reactions.

In one of the first user experiments at the Small Quantum Systems (SQS) instrument, we have used the very intense, femtosecond soft X-ray pulses from the European XFEL to record snapshot images of the complete structure of a molecule with eleven atoms, including all hydrogens, by Coulomb explosion imaging (CEI) using the reaction microscope (REMI) end station. Up to now, it was generally expected that, in order to image polyatomic molecules, it would be necessary to record essentially all charged fragments in coincidence – a requirement that is currently impossible to fulfil for more than a few atoms within a reasonable measurement time. However, here we demonstrate that, while it was possible to record up to six-fold ion coincidences in the experiment, even three-fold ion coincidences can be sufficient to image the full structure of a molecule. The X-ray intensity at SQS (up to 10^{13} photons/ μm^2) is high enough to produce extreme charge states in heavy atoms (e.g. up to 42+ in xenon atoms), and to Coulomb-explode molecules into individual atoms very quickly, such that the initial molecular structure is well preserved in the recorded momenta of all ions.

The intriguingly clear momentum images allow us to identify each atom's position in the molecule unambiguously, and thus make it possible to trace the rearrangement of charge from the absorbing heavy atom to the other atoms in the molecule. Moreover, by combining our experimental results with state-of-the-art molecular dynamics calculations, we are able to follow in detail the charge-up dynamics of the molecule throughout the femtosecond X-ray pulse, thus gaining unprecedentedly detailed insights into the ultrafast charge rearrangement and fragmentation dynamics.

Given the femtosecond X-ray pulse duration, the presented results can, in the next step, readily be employed to monitor the temporal evolution of the molecular structure in a pump-probe experiment – thus bringing the long-standing dream of recording molecular movies of photo-chemical reactions very close to realisation.

Email of corresponding author: rebecca.boll@xfel.eu

Insights into the donor-acceptor properties of base metal free dyads for photocatalysis

Matthias Bauer

University of Paderborn, Faculty of Science, Warburger Str. 100, 33098 Paderborn

The conversion of sunlight into fuels or chemicals gains lots of attention by the so-called Sun-to-X approach. The reduction of protons to hydrogen using sunlight is one of the prototype reactions here. In particular with the renaissance of fuel cells as an alternative to batteries, sustainable hydrogen production becomes even more important.

While two-component proton reduction systems employ photosensitisers and catalysts in a diffusion driven process, molecular assemblies of both, so-called dyads could offer a vectorial electron transfer. This could reduce the lifetime limitations for the electron transfer in photocatalytic reactions.

Using base metals instead of noble metals increases the sustainable character of photocatalytic proton reduction. Both in photosensitizers and photocatalysts, metals like iron and cobalt can be used, but so far, no photocatalytically active dyads using only base metals exist. Achieving competitive activity of such noble-metal-free dyads requires major efforts in chemical design. Due to the very limited knowledge about the properties and functionality of base metal compounds in this context, fundamental insights into their working principle are mandatory.

X-ray emission and absorption spectroscopy (XES) provides unique details about the electronic and geometric structure of iron and cobalt photosensitisers and photocatalysts¹. In particular for Fe-Co dyads as shown in Fig. 1, ultrafast cutting edge two-colour emission experiments² at the European XFEL and other X-ray free electron lasers are possible and of unique advantage to understand the electron transfer properties after photoexcitation. In these experiments, which will be presented in detail with this contribution, the emission lines of both metal sites in dyads are probed simultaneously, avoiding ambiguities in time zero and showing unprecedented new insights into the excited state behaviour of this new compound class. The obtained results indicate that a simple view on the electron transfer is not appropriate and needs to be exchanged by a detailed picture to achieve optimal photocatalytic activity.

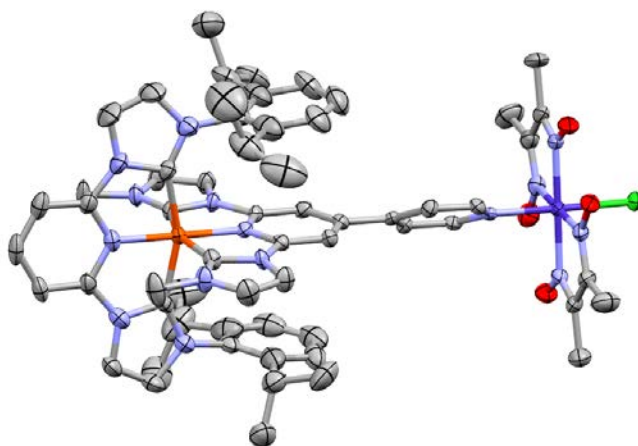

Figure 1. X-ray structure of a bimetallic dyad using iron as photosensitiser and cobalt as catalyst.

References

- [1] M. Bauer, M. Phys. Chem. Chem. Phys. 2014, 16, 13827.
- [2] A. Kalinko, W. Caliebe, R. Schoch, M. Bauer, J. Synchrotron Rad. 2020, 27, 31.

Email of corresponding author: matthias.bauer@upb.de

MHz X-ray Microscopy at Synchrotron and Free Electron Laser Facilities

Patrik Vagovič^{1,2,3}, Tokushi Sato,^{1,2} Ladislav Mikeš,² Grant Mills,² Rita Graceffa,² Frans Mattsson,⁴ Pablo Villanueva-Perez,^{4,1} Alexey Ershov,⁵ Tomáš Faragó,⁵ Jozef Uličný,⁶ Henry Kirkwood,² Romain Letrun,² Rajmund Mokso,⁴ Marie-Christine Zdora,^{7,8,9} Margie P. Olbinado,¹⁰ Alexander Rack,¹⁰ Tilo Baumbach,⁵ Joachim Schulz,² Alke Meents,¹ Henry N. Chapman¹ and Adrian P. Mancuso^{2,11}

¹Center for Free-Electron Laser, Notkestraße 85, 22607 Hamburg, Germany

²European XFEL, Holzkoppel 4, 22869 Schenefeld, Germany

³Institute of Physics, Academy of Sciences of the Czech Republic v.v.i., Na Slovance 2, 182 21, Praha 8, Czech Republic

⁴Lund University, Sweden

⁵Institute for Photon Science and Synchrotron Radiation, Karlsruhe Institute of Technology (KIT), Herrmann-von-Helmholtz-Platz 1, 76344 Eggenstein-Leopoldshafen, Germany

⁶Faculty of Science, Department of Biophysics, P. J. Šafárik University, Jesenná 5, 04154 Košice, Slovakia

⁷Diamond Light Source, Harwell Science and Innovation Campus, Didcot, Oxfordshire OX11 0DE, UK

⁸Department of Physics & Astronomy, University College London, London, WC1E 6BT, UK

⁹Department of Physics & Astronomy, University of Southampton, Southampton SO17 1BJ, UK

¹⁰ESRF – The European Synchrotron, 71 Avenue des Martyrs, 38000 Grenoble, France

¹¹Department of Chemistry and Physics, La Trobe Institute for Molecular Science, La Trobe University, Melbourne, Victoria 3086, Australia

Modern emerging technologies, such as additive manufacturing, bio-printing, and new material production and processing, require novel metrology tools to probe fundamental high-speed dynamics happening in such systems. Such processes are stochastic in nature and conventional pump and probe stroboscopic approaches are not sufficient to provide accurate information about their complex nature. We present the application of the megahertz European X-ray Free-Electron Laser (EuXFEL) and Synchrotron sources to image the such fast stochastic processes and discuss future possibilities and applications of this method especially at new MHz rate

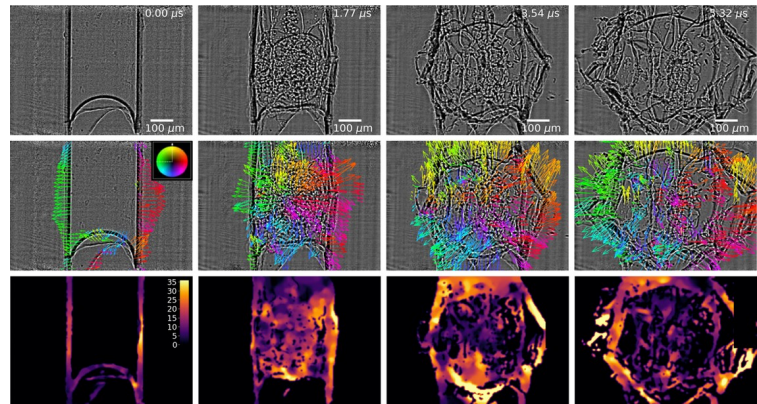

Figure 1: X-ray sequence of laser-induced dynamics in water filled glass capillary imaged at 1.13 MHz sampling rate (top) and processed velocity vectors (middle) and velocities (bottom).

XFEL photon sources. We present a first demonstration of the MHz X-ray microscopy method performed at EuXFEL of laser induced dynamics on water-filled capillaries with micrometer-scale spatial resolution sampled at 1.13 MHz (Fig. 1). This work opens up new possibilities for the characterisation of MHz stochastic processes on the nanosecond to microsecond time scales with object velocities up to a few kilometers per second and possibility to obtain 3D information per one pulse with sampling rate up to 4.5 MHz and photon energies up to 25 keV at EuXFEL.

Email of corresponding author: patrik.vagovic@cfel.de

Nucleation dynamics of skyrmion lattice from magnetic fluctuations phase

Felix Büttner¹, Bastian Pfau², Marie Böttcher³, Michael Schneider², Giuseppe Mercurio⁴, Christian M. Günther^{5,6}, Piet Hessing², Christopher Klose², Angela Wittmann¹, Kathinka Gerlinger², Lisa-Marie Kern², Christian Strüber², Clemens von Korff Schmising², Josefin Fuchs², Dieter Engel², Alexandra Churikova¹, Siying Huang¹, Daniel Suzuki¹, Ivan Lemesh¹, Mantao Huang¹, Lucas Caretta¹, David Weder², Sergey Zayko⁷, Kai Bagschik⁸, Robert Carley⁴, Laurent Mercadier⁴, Justine Schlappa⁴, Alexander Yaroslavtsev⁴, Loïc Le Guyader⁴, Natalia Gerasimova⁴, Andreas Scherz⁴, Carsten Deiter⁴, Rafael Gort⁴, David Hickin⁴, Jun Zhu⁴, Monica Turcato⁴, David Lomidze⁴, Florian Erdinger⁹, Andrea Castoldi^{10,11}, Stefano Maffessanti⁸, Matteo Porro⁴, Andrey Samartsev⁴, Claus Ropers⁷, Jairo Sinova³, Johan H. Mentink¹², Bertrand Dupé³, Geoffrey S. D. Beach¹, and Stefan Eisebitt^{2,5}

¹*Department of Materials Science and Engineering, MIT, Cambridge, Massachusetts, USA*

²*Max-Born-Institut, Berlin, Germany*

³*Institut für Physik, Johannes Gutenberg Universität Mainz, Germany*

⁴*European XFEL GmbH, Schenefeld, Germany*

⁵*Institut für Optik und Atomare Physik, Technische Universität Berlin, Berlin, Germany*

⁶*Zentraleinrichtung für Elektronenmikroskopie (ZELMI), Technische Universität Berlin, Germany*

⁷*University of Göttingen, 4th Physical Institute, Göttingen, Germany*

⁸*Deutsches Elektronen-Synchrotron (DESY), Hamburg, Germany*

⁹*Institute of Computer Engineering, Heidelberg University, Germany*

¹⁰*Dipartimento di Elettronica, Informazione e Bioingegneria, Politecnico di Milano, Italy*

¹¹*Istituto Nazionale di Fisica Nucleare, Sezione di Milano, Italy*

¹²*Radboud University Nijmegen, Institute for Molecules and Materials, Nijmegen, Netherlands*

Magnetic skyrmions are topological quasi-particles with diameters down to a few nanometers. These spin structures are attractive as information entities for spintronic applications, in particular for the realisation of current-driven magnetic shift registers, so-called racetrack memories. Generation, transport and annihilation of skyrmions are fundamental operations in this context. The non-trivial topology characterising skyrmions is believed to enhance their stability. However, despite the expected conservation of topological charge, skyrmion creation and annihilation through topological switching can be induced via field, current, or optical excitation. Yet, the mechanism and dynamics of the topological transition leading to a nucleation of skyrmions has remained unresolved. Here, we reveal the physics of ultrafast laser-induced topological switching by time-resolved X-ray scattering combined with atomistic simulations. Single-shot-resolved experiments at European XFEL allow us to track the magnetic correlation length and size of skyrmions nucleated in a short-range ordered lattice.

We find that skyrmion formation is a two-step process. First, the optical heat pulse induces a topological fluctuation phase where enough energy is available for atomistic spin-flip transitions. Subsequent to this nucleation step, micromagnetic energies lead to the collapse of antiskyrmions and coarsening of skyrmions, which freeze into a short-range ordered array with a controllable density upon rapid cooling. This ultrafast and controlled generation of topological charge paves the way towards new devices based on topological opto-spintronics.

Email of corresponding author: bastian.pfau@mbi-berlin.de

Femto-second holographic X-ray imaging with FEL pulses of laser-induced cavitation bubbles

M. Vassholz¹, H. P. Höppe¹, M. Osterhoff¹, J. Hagemann², A. Schropp², C. Schroer²,
J. M. Rosselló³, R. Mettin³, J. Möller⁴, U. Bösenberg⁴, J. Hallmann⁴, A. Madsen⁴
and T. Salditt¹

¹ *Institut für Röntgenphysik, Georg-August-Universität Göttingen,*

² *Deutsches Elektronen-Synchrotron (DESY)*

³ *Drittes Physikalisches Institut, Georg-August-Universität Göttingen*

⁴ *MID instrument, European XFEL*

Small transient or strongly driven cavitation bubbles in liquids exhibit a range of interesting nonlinear effects, from violent collapse and shockwave emission, sonoluminescence, and chemical reactions. For well-controlled experiments on cavitation bubbles, ultra-fast laser pulses are commonly used, which seed cavitation bubbles by a transition from a laser-generated plasma to a hot, compressed bubble nucleus, and finally to an expanding gas and vapour bubble in the liquid environment. This transition from the plasma to a bubble, the plasma growth, subsequent cooling of the plasma and generation of waves in the medium, as well as the precise states of matter in the bubble remain elusive. Apart from fundamental aspects of non-equilibrium physics, these processes are also relevant for applications such as laser surgery. More generally, cavitation effects are relevant for many more applications such as ultrasonic cleaning, and sonochemistry. For several decades, the main tool to study bubble dynamics has been optical imaging, with up to 100 million frames per second by high-speed CCD cameras. However, due to the small scales and the fast dynamics, imaging of the bubble interior and its environment remains a huge challenge. Nanosecond time resolution and sub-micrometer spatial resolution are required to follow the motion of the phase boundary and the dynamics of the bubble interior.

Coherent imaging with X-ray free-electron laser (XFEL) pulses now has enabled a quasi-instantaneous high resolution structural probe of cavitation bubbles at different stages after seeding. These novel capabilities to investigate extreme states of bubble generation and collapse offer a complementary contrast to ultra-fast optical microscopy and may help to improve our basic physical understanding of these processes. In this work we demonstrate how micrometer-sized bubble states can be probed by coherent X-ray flash imaging. An infrared ns laser pump seeds the cavitation process, while the X-ray laser is used to image the bubble by in-line holography using a highly focused XFEL pulse. By forward modelling and iterative phase retrieval the X-ray holograms are analysed to extract density and pressure distributions of the cavitation bubbles in space and time. The experiment provides an insight in the dynamics of single individual bubbles, with parameters histogrammed for over 10000 individually probed bubbles.

Email of corresponding author: tsaldit@gwdg.de

Static High Pressure Experiments on European XFEL

Stewart McWilliams¹, Hanns-Peter Liermann²
and the HED-DAC Collaboration

¹ *School of Physics and Astronomy & Centre for Science at Extreme Conditions,
University of Edinburgh, Edinburgh, UK EH10 5LS*

² *Deutsches Elektronen-Synchrotron (DESY) Hamburg*

In recent years, the exploration of high pressure states of matter using X-ray free electron lasers (XFELs) has revolutionised our knowledge of materials' structure and phase at extremes. With these X-ray sources intrinsically pulsed on femtosecond timescales, such studies have to date largely employed dynamic compression, where extreme pressures produced by transient pressure waves, e.g. generated by an optical laser pulse, can be quickly probed. Together with corresponding developments in dynamic compression at synchrotron facilities, the exploration of high pressure structural properties of matter using dynamic compression has seen a period of remarkable growth.

Alternatively, static compression, wherein matter is compressed isothermally in pressure cells, has long been used at synchrotron facilities in the exploration of high pressure structural states. However, the coupling of static compression with next generation XFEL techniques has been slow to materialise, in part because many traditional static high pressure techniques lack any dynamic aspect for which pulsed X-ray radiation is immediately beneficial. However, there is increasing realisation of a wide range of dynamic measurements performed using static pressure cells that can benefit from intense XFEL radiation, some made possible only at these sources. Rapid XFEL measurements can also overcome problems that often hamper traditional static experiments, such as chemical contamination and containment failure. XFEL facilities are now moving to accommodate static compression experiments, most notably, the European XFEL.

The European XFEL's High Energy Density (HED) instrument is dedicated to the study of matter at extreme conditions (e.g. of temperature and pressure). At this instrument, a dedicated platform for high pressure experiments using static compression cells has been developed using diamond-based anvils (the so-called Diamond Anvil Cell, or DAC), using a special interaction chamber (IC2). Nominally transparent to hard X-rays (>10 keV photon energy), diamond anvil cells enable the hermetic enclosure of samples at pressures of millions of atmospheres, similar to conditions occurring in the deep interior of the earth. This platform enables XFEL exposure, excitation, and probing of high pressure samples, with sample state studied by X-ray diffraction and optical pyrometry, and further modulated by rapidly varying pressure and temperature using cutting-edge piezo-driven cells and pulsed optical laser heating.

The HED instrument opened to first users in 2019, with the first community-wide experiment using DAC techniques, performed with the involvement of over 70 scientists from 7 nations (the HED-DAC Collaboration), conducted in October 2019, following preliminary experiments at the Pohang Accelerator Laboratory's XFEL in S. Korea. The objective of the EuXFEL experiment was to explore how matter under pressure responded to hard X-ray (17.8 keV) radiation at MHz repetition rates, including X-ray heating, structural transformation, melting, and chemical reaction, in compressed materials ranging from metals such as iron to molecular insulators such as hydrogen. The serial XFEL exposures excited extreme states and processes while simultaneously providing a rapid snapshot of the sample transformations. In achieving conditions of pressure up to and exceeding one million atmospheres, temperature of thousands of Kelvin, and timescales (of order 1 microsecond) compatible with the study of equilibrium matter, the experiment closely replicated the conditions and materials states found deep within planetary interiors. These studies go beyond a 'diffract-and-destroy' strategy, with the experiments revealing diamond anvils and samples to be robust under XFEL radiation, even at higher irradiances which annihilate similar samples at ambient conditions.

This talk will present the facility design and experimental benchmarks achieved through these first experiments, with an outlook to the next generation of static high pressure studies at European XFEL. In summary, XFELs hold the possibility of providing unprecedented access to the structural and phase behaviour of extreme states of matter, with their potential has now been realised at European XFEL.

Email of corresponding author: rs.mcwilliams@ed.ac.uk

Elastic and inelastic X-ray scattering from isochorically heated carbon

Dominik Kraus^{1,2}, Katja Voigt^{1,2}, Min Zhang^{1,3}, Nicholas Hartley¹, Marion Harmand⁴, Alexis Amouretti⁴, Karen Appel⁵, Mandy Bethkenhagen⁶, Erik Brambrink⁵, Valerio Cerantola⁵, Deniza Chekrygina¹, Tilo Döppner⁷, Roger Falcone⁸, Katerina Falk^{1,2}, Luke Fletcher⁹, Dirk Gericke¹⁰, Siegfried Glenzer⁹, Sebastian Göde⁵, Stefan Hau-Riege⁷, Lingen Huang¹, Mikako Makita⁵, Alexander Pelka¹, Clemens Prescher¹¹, Anja Schuster^{1,2}, Michal Smid¹, Ronald Redmer⁶, Gerd Röpke⁶, Toma Toncian¹, Jan Vorberger¹, Ulf Zastra⁵, Thomas Preston⁵

¹*Helmholtz-Zentrum Dresden-Rossendorf, Dresden, Germany*

²*Technische Universität Dresden, Dresden, Germany*

³*University of Science and Technology of China, Hefei, China*

⁴*Université Pierre et Marie Curie, Paris, France*

⁵*European XFEL GmbH, Schenefeld, Germany*

⁶*Universität Rostock, Rostock, Germany*

⁷*Lawrence Livermore National Laboratory, Livermore, USA*

⁸*University of California, Berkeley, USA*

⁹*SLAC National Accelerator Laboratory, Menlo Park, USA*

¹⁰*University of Warwick, Coventry, United Kingdom*

¹¹*DESY, Hamburg, Germany*

As one of the very first user experiments at the HED instrument of European XFEL, we have realised an experimental platform for precisely studying the dynamics of dense carbon plasmas using spectrally resolved X-ray scattering, reaching a significantly enhanced data quality compared to previous proof-of-principle experiments at LCLS [1]. Elastic scattering from tightly bound electrons is highly sensitive to the ionic correlations and can therefore determine ultrafast changes in the ionic structure [2,3]. At the same time, inelastic scattering from free electrons gives direct access to the energy distribution of the electrons, from which the degree of ionisation and an average electronic temperature can be inferred [4]. Via inelastic scattering from bound electrons, we can accurately resolve the ionisation K-edge which provides the corresponding ionisation energy and thus the ionisation potential depression which, for dense plasma, is an area of very active scientific debate. Moreover, inelastic scattering from collective electron fluctuations can provide an additional constraint on the electronic temperature and ionisation. Finally, applying the 4-bounce monochromator, we have demonstrated the applicability of X-ray Raman spectroscopy as a highly promising diagnostics for electronic structure of dense plasmas, in particular for rep-rated experiments that will soon be enabled by the HIBEF infrastructure.

[1] D. Kraus et al., *Plasma Physics and Controlled Fusion* 61, 014015 (2019).

[2] S. P. Hau-Riege et al., *Physical Review Letters* 108, 217402 (2012).

[3] N. J. Hartley et al., *High Energy Density Physics* 32, 56-62 (2019).

[4] S. H. Glenzer and R. Redmer, *Reviews of Modern Physics* 81, 1625-1663 (2009).

FLASH – today and tomorrow – status report and future plans

Martin Beye for the FLASH team

Deutsches Elektronen-Synchrotron DESY, Hamburg, Germany

In 2019, FLASH has been operated for a record high of about 4600 hours to deliver free-electron laser (FEL) beam to users, yielding in total about 6400 hours of beam for FEL experiments thanks to about 40% of parallel operation of the two undulator lines FLASH1 and FLASH2. The machine uptime of 98% also reached a new peak. With the routine operation of the new pump-probe laser at the FLASH2 beamlines FL24 and FL26, the tunable undulators in the FLASH2 section can be fully exploited for time-resolved experiments that also demand continuous scans of the FEL wavelength.

At the new beamline FL21 at FLASH2, a setup for THz streaking is continuously improved and further standardised in order to diagnose FEL arrival time and pulse lengths routinely on a shot-to-shot basis in non-invasive mode. Beamline FL26 with the Reaction Microscope end station now comprises an HHG setup synchronised with the FEL for novel XUV/VUV pump-probe experiments, installed within a BMBF collaborative research project led by the Leibniz Universität Hannover.

In order to further enhance parallel operation of FLASH1 and FLASH2 along with improvement of the beam quality and the FEL parameter range, the FLASH2020+ project has made significant steps forward with the completion of the conceptual design report. It is planned to develop FLASH1 into a high repetition rate, externally seeded FEL with fully coherent pulses (and fully tunable undulators), while FLASH2 focusses on ultrashort pulses covering the full soft X-ray range up to 1keV photon energy including harmonics.

In the talk, I will give an update on the status of FLASH, review instrumental developments and present some selected science results. Furthermore, a quick overview of the planned upgrades within the FLASH2020+ project is given together with a description of the current status.

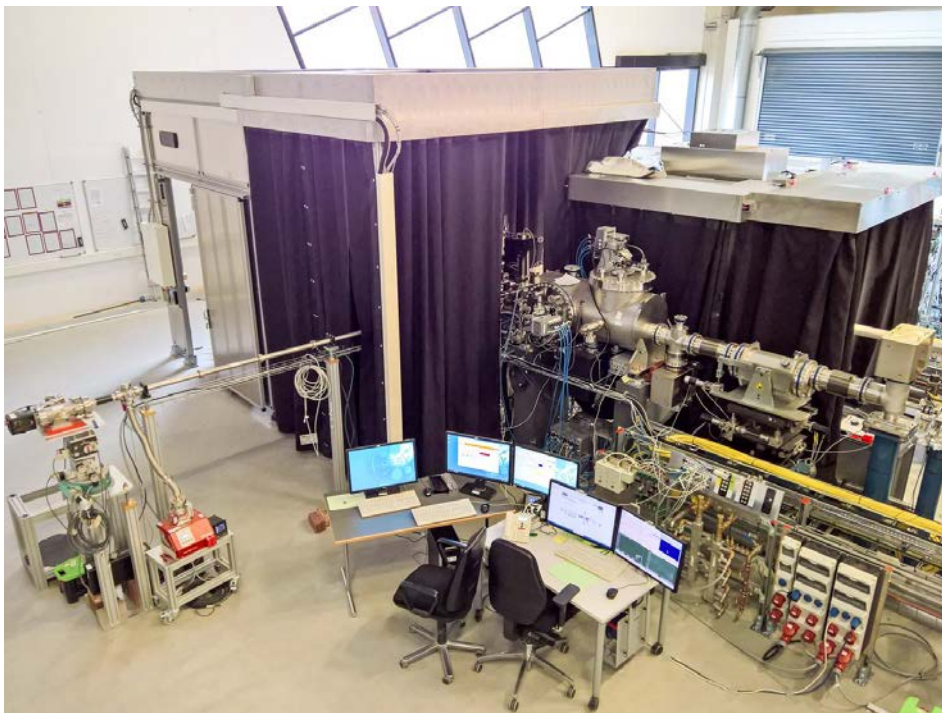

The FLASH2 beamline FL24 at DESY, providing tunable FEL focal sizes and a large laser tent for user-provided experimental setups. Next to the large tent is a separate smaller laser tent for independent pump-probe laser beam preparation and monitoring.

Email of corresponding author: martin.beye@desy.de

THz/XUV pump-probe experiments for studying local fields and dynamics at surfaces

Kay Waltar¹, Johannes Haase², Rui Pan³, Torsten Golz³, Pavel Kliuiev¹, Saša Bait³, Nikola Stojanovic³, Matthias Hengsberger¹, Jürg Osterwalder¹, Luca Castiglioni¹

¹ *Department of Physics, University of Zurich, Zurich, Switzerland*

² *Laboratory for Catalysis and Sustainable Chemistry, Paul Scherrer Institut, Villigen, Switzerland*

³ *Deutsches Elektronen-Synchrotron-DESY, Hamburg, Germany*

Intense THz fields can be used to excite specific low-frequency modes in condensed matter or drive confined currents in nano-structured arrays, paving the way for a new class of optoelectronic devices. At the same time, these fields are themselves strongly influenced by the interaction with solid surfaces and nanostructures. A THz pump - XUV photoemission probe experiment can in principle study both sides of this coin. During the THz pump pulse, photoelectron streaking can be used for the polarisation-sensitive reconstruction of all electric field components at dielectric and metallic surfaces [1]. Between pump pulses, the XUV photoelectron spectrum and angular distribution can provide information on the THz-induced structural dynamics of the studied system.

In a proof-of-principle experiment we have studied the system of CO molecules adsorbed on Pt(111) at the THz beamline of the FLASH free-electron laser, using both, a single crystal sample and ultrathin films with Pt(111) islands of the order of few 100 nm lateral dimensions grown on Si(111). Using a conventional hemispherical electron energy analyser with a two-dimensional detector, resolving kinetic energy and one momentum component, the electrical field components of the THz pulses perpendicular and parallel to the Pt(111) surface could be reconstructed [2]. As expected, the parallel component is completely suppressed on the Pt(111) single crystal sample due to metallic screening, while it persists on the nanostructured film sample. Electric field simulations of THz radiation incident on nanometer-sized metallic islands show strong local variations of both field components in close proximity of these islands which cannot be resolved in these experiments. The distance over which the emitted photoelectrons interact with the THz pulse limits the spatial resolution at which the electrical fields can be characterised. The attempt to resonantly excite a low-frequency frustrated translational mode of CO on Pt(111) by means of these pulses [3] was unsuccessful as the signature of the structural dynamics in the XUV-excited photoelectron angular distribution was below the detection limit due to the limited THz field amplitude. Our results nevertheless help to identify the parameters required for studying structural dynamics at surfaces by means of THz pump - photoemission probe experiments.

[1] K. Waltar et al., *Opt. Express* 26, 8364 (2018).

[2] K. Waltar et al., *Optica* 6, 1431 (2019).

[3] M. Greif et al., *Struct. Dynamics* 2, 035102 (2015); and *Struct. Dynamics* 3, 059901 (2016).

Email of corresponding author: osterwal@physik.uzh.ch

Distorting atoms – The nonlinear driving of atom-specific transitions with intense XUV light

Christian Ott

Max-Planck-Institut für Kernphysik, Saupfercheckweg 1, 69117 Heidelberg, Germany

With ultrafast XUV transient absorption spectroscopy, carried out in Fraunhofer-type transmission geometry by directly measuring the attenuated light, one is sensitive to both the linear and nonlinear XUV-optical dipole response of the electron dynamics in the local vicinity of an atom, enabling a direct view into the bound-state dynamics of excited electrons.

In this talk, we will present new results of direct XUV nonlinear effects in both helium [1] and neon [2] atoms. Intense XUV pulses from the free-electron laser (FEL) in Hamburg (FLASH) are tuned to photon energies of 60 eV and 50 eV, respectively, for the helium and neon absorption targets. The pulse energy ranges up to multiple ten μJ with a photon fluence of several J/cm^2 in the interaction volume. Depending on the stochastic substructure of the FEL pulses, intensities up to $10^{15} \text{ W}/\text{cm}^2$ can be reached with these parameters.

With increasing XUV intensity, we observe a significant change of the asymmetric Fano line-shape of the strongly driven $1s^2 - 2s2p$ two-electron transition in helium to a more symmetric absorption line at 60 eV photon energy [1]. Supported by a quantitative model we show how transient strong-XUV-field-induced energy shifts are directly encoded into the shape of the resonant absorption profile. The model also predicts an inversion of having more population in the upper $2s2p$ state than in the lower $1s^2$ ground state during a sizeable fraction of the 17 fs autoionisation lifetime.

For the case of neon, the XUV intensity is high enough to generate a significant abundance of Ne^{2+} ions within the target volume through the absorption of two photons at 50 eV. The Ne^{2+} ions are identified via $^3\text{P}-^3\text{D}$ $2p-3d$ spin-orbit multiplet transitions within the measured XUV absorption spectrum. Depending on the XUV intensity, we observe 10-meV-scale spectral shifts of these lines due to the ac-Stark effect [2]. Furthermore, a few-femtosecond coherence enhancement through plasma-induced diffraction in the neon target is observed in the data and reproduced by a model of the characteristic SASE (self-amplified spontaneous emission) temporal structure of the FEL pulses.

New insights into strong-XUV-field light-matter interaction can thus be gained, demonstrating the feasibility of quantum control of specific transitions characteristic to each atom. The results also pave the road towards site-specific quantum control of molecular dynamics and chemical reactions by using intense and ultrashort FEL pulses.

- [1] C. Ott, L. Aufleger, T. Ding, M. Rebholz, A. Magunia, M. Hartmann, V. Stooß, D. Wachs, P. Birk, G. D. Borisova, K. Meyer, P. Rupprecht, C. da Costa Castanheira, R. Moshhammer, A. R. Attar, T. Gaumnitz, Z.-H. Loh, S. Düsterer, R. Treusch, J. Ullrich, Y. H. Jiang, M. Meyer, P. Lambropoulos and T. Pfeifer, *Phys. Rev. Lett.* 123, 163201 (2019).
- [2] T. Ding, M. Rebholz, L. Aufleger, M. Hartmann, K. Meyer, V. Stooß, A. Magunia, D. Wachs, P. Birk, Y. Mi, G. D. Borisova, C. da Costa Castanheira, P. Rupprecht, Z.-H. Loh, A. R. Attar, T. Gaumnitz, S. Roling, M. Butz, H. Zacharias, S. Düsterer, R. Treusch, S. M. Cavaletto, C. Ott and T. Pfeifer, *Phys. Rev. Lett.* 123, 103001 (2019).

Email of corresponding author: christian.ott@mpi-hd.mpg.de

X-ray Lasers Shed Light on the Mysteries of Water

Anders Nilsson

Division of Chemical Physics, Department of Physics, Stockholm University, Sweden

Water is of extreme importance for our society and the key component of life as we know it but it is also of extraordinary interest due to its remarkable physical properties that differ from almost all other liquids. Deviation of water's properties from a simple liquid exists already in the ambient temperature regime and then becomes strongly enhanced upon supercooling. In particular the finding that the thermodynamic response and correlation functions appear to diverge towards a singular temperature estimated by power-law fits of about 228 K has led to several hypotheses about the origin of water's anomalous properties. One hypothesis to explain the apparent divergence is that there exists a liquid-liquid transition with a liquid-liquid critical point at rather high positive pressures. In this scenario the Widom line, defined as the locus of correlation length maxima in the P-T plane, emanates from the critical point as a continuation of the liquid-liquid transition line into the one-phase region and the divergence in the response functions is towards this line. The challenge is that the temperature T_s lies below the homogeneous ice nucleation temperature 232 K, a region of the phase diagram that has been denoted as "no man's land", since ice crystallization occurs on much faster time scale compared to the experimentally accessible time scale in a typical laboratory setting.

Here I will present how X-ray lasers can be used to probe the liquid in the deep supercooled water regime inside no-man's land. In particular I will discuss if a liquid-liquid transition, Widom line and a critical point exists in deep supercooled water causing fluctuations all the way up to ambient temperature.

Email of corresponding author: anders.s.nilsson@su.se

Imaging nanostructures in superfluid helium droplets

R. M. P. Tanyag^{1, 2, 3}, A. Ulmer², L. Gomez³, C. Bacellar⁴, T. Baumann⁵, C. Bernando³, R. Boll⁵, M. Bucher⁶, A. Chatterley⁷, A. de Fanis⁵, B. Erk⁸, S. Erukala³, A. Feinberg³, T. Fennel⁹, K. Ferguson⁶, P. Grychtol⁵, R. Hartmann¹⁰, S. Hauf⁵, A. Heilrath², A. Hoffmann¹, M. Ilchen⁵, M. Izquierdo⁵, C. Jones³, K. Kolatzki¹, B. Krebs⁹, B. Kruse⁹, M. Kuster⁵, B. Langbehn², J. Mahl⁴, T. Mazza⁵, K.-H. Meiwes-Broer⁹, J. Montaño⁵, V. Music⁵, G. Noffz², S. O'Connell³, W. Pang³, D. Rivas⁵, C. Saladrigas⁴, D. Schlosser¹⁰, P. Schmidt⁵, F. Seel², L. Seiffert⁹, B. Senfftleben¹, H. Stapelfeldt⁷, L. Strüder¹⁰, J. Tiggesbäumker⁹, B. Toulson⁴, D. Verma³, H. Yousef⁵, M. Zabel⁹, P. Walter⁶, M. Meyer⁵, Y. Ovcharenko⁵, C. Bostedt⁶, O. Gessner⁴, D. Rupp^{1, 2}, A. Vilesov³, and T. Möller²

¹Max Born Institute, Berlin, Germany

²Technical University of Berlin, Berlin, Germany

³University of Southern California, Los Angeles, California, USA

⁴Lawrence Berkeley National Laboratory, Berkeley, California, USA

⁵European X-ray Free Electron Laser, Schenefeld, Germany

⁶Linac Coherent Light Source SLAC, Menlo Park, California, USA

⁷Aarhus University, Aarhus, Denmark

⁸Deutsches Elektronen-Synchrotron, Hamburg, Germany

⁹University of Rostock, Rostock, Germany

¹⁰PN Sensor, Munich Germany

Helium droplets are intriguing media for investigating particle growth. The droplet serves as an individual cryostat where captured dopant particles move without friction and spontaneously assemble far-from equilibrium nanostructures. In this talk, we report on X-ray coherent diffractive imaging of nanostructures grown in free, single, rotating, superfluid helium-4 droplets with diameters ranging from 150 to 2000 nm. The data presented here are collected from experiments conducted at the Linac Coherent Light Source at SLAC and at the European X-ray Free Electron Laser. Different dopant particles with different interatomic or intermolecular forces of attraction are used to investigate the effect of chemical bonding on the formation and growth of these nanostructures. Since quantum vortices are known to be present in superfluid droplets, we will also comment on how their presence influences the instantaneous positions of the dopants and nanostructure formation. Ultimately, it is the intention of these measurements to develop a model for dopant aggregation in helium droplets and the possibility of controlling their growth.

Email of corresponding author: tanyag@tu-berlin.de or tanyag@mbi-berlin.de

Evidence of Extreme Ultraviolet Superfluorescence in Xenon

Laurent Mercadier¹, Andrei Benediktovitch², Hendrik Bekker³, Sven Bernitt³, Michael A. Blessenohl³, Rebecca Boll¹, Cédric Bomme², Christoph F. O. Bostedt⁴, Maximilian Bucher⁴, Jonathan Correa², José R. Crespo López-Urrutia³, Stepan Dobrodey³, Benjamin Erk², Mehdi A. Khalaf⁵, Tim Laarmann², Pascal Lablanquie⁵, Bruno Langbehn⁶, Vinay P. Majety², Thomas Möller⁶, Alexander Nelde⁶, Jérôme Palaudoux⁵, François Penent⁵, Olivier Peyrusse⁷, Andreas Przystawik², Daniel Rolles^{2,8}, Artem Rudenko⁸, Daniela Rupp⁶, Alvaro Sanchez-Gonzalez⁹, René Steinbrügge³, Sven Toleikis², Clemens Weninger², Zhong Yin² and Nina Rohringer^{2,10}

¹European XFEL, 22869 Schenefeld, Germany

²Deutsches Elektronen-Synchrotron (DESY), 22607 Hamburg, Germany

³Max-Planck-Institut für Kernphysik, 69117 Heidelberg, Germany

⁴Argonne National Laboratory, Lemont, IL 60439, USA

⁵Laboratoire de Chimie Physique-Matière et Rayonnement, Université Pierre et Marie Curie, F-75231 Paris Cedex 05, France

⁶Institut für Optik und Atomare Physik, Technische Universität Berlin, Berlin 10623, Germany

⁷Aix-Marseille Université, CNRS UMR 7345, PIIM, Marseille, France

⁸J. R. Macdonald Lab, Department of Physics, Kansas State Univ., Manhattan, Kansas 66506, USA

⁹Department of Physics, Imperial College London, London SW7 2AZ, United Kingdom

¹⁰Department of Physics, Universität Hamburg, 20355 Hamburg, Germany

Superfluorescence describes the spontaneous, collective decay of a macroscopic ensemble of excited atoms or ions which have been prepared in a population-inverted state. It results in the emission of collimated, highly intense radiation pulses. Observing superfluorescence in the extreme ultraviolet (XUV) and soft X-ray wavelength regimes is difficult because of the disparate timescales of two competing processes: the very fast Auger decay on the fs (or Coster-Kronig decays on sub-fs) timescale limiting the lifetime of inner-valence vacancies and coherences, and the comparatively long (ns) radiative transition times.

Here, we demonstrate XUV superfluorescence by focusing the FLASH free-electron laser (FEL) in a cell filled with Xe gas. The FEL photoexcites the 4d shell of Xe atoms that rapidly decay via various Auger channels, thus creating a long-lived population inversion within the n=5 shell (Auger pumping). On the timescale of 10 to 100 ps, a macroscopic polarization builds up in the medium, resulting in superfluorescent emission of several Xe lines in the forward direction. As the number of emitters in the system is increased by either raising the pressure or the pump-pulse energy, the emission yield grows exponentially over four orders of magnitude and reaches saturation. With increasing yield, we observe line broadening, a manifestation of superfluorescence in the spectral domain. Our novel theoretical approach, based on a full quantum treatment of the atomic system and the irradiated field, shows quantitative agreement with the experiment and supports our interpretation.

In a second experiment, we study the emission of an ensemble of Xe clusters photoexcited by the same FEL, in transversal (fluorescence spectroscopy) and forward direction. Despite the different nature of the medium, we observe amplification of the same emission lines in forward direction as in the gas phase, with strikingly different characteristics. The creation of a nano-plasma in the warm dense matter regime, characterized by fluorescence spectroscopy, adds dephasing via heating and collisions which results in spectral broadening and quenches the superfluorescence. However, as our theory and extensive numerical simulations suggest, this harsh environment also opens an additional pathway to create strong, laser-like emission: population inversion is created by electron-ion collisions and decoherence processes can be characterized by a phenomenological dephasing time in the range of 100 - 200 fs.

Email of corresponding author: laurent.mercadier@xfel.eu

Transient magnetic scattering in thin Co/Pt multilayers upon femtosecond IR excitation

M.V. Baidakova^{1,2}, R. Carley³, R. Gort³, G. Grübel⁴, E. Jal⁵, E. Yu. Lobanova^{1,2}, L. Mercadier³, S. L. Molodtsov^{1,3,6}, L. Müller⁷, A. Phillipi-Kobs⁴, D. Potorochin^{1,4,6}, W. Roseker⁴, A. Scherz³, J. Schlappa³, S. M. Suturin², B. Van Kuiken³, A. Yaroslavtsev³ and I. I. Pronin^{1,2}

¹ ITMO University, St. Petersburg, Russia

² Ioffe Institute, St. Petersburg, Russia

³ European XFEL, Schenefeld, Germany

⁴ DESY, Hamburg, Germany

⁵ Sorbonne University, Paris, France

⁶ TU Freiberg, Germany

⁷ University of Hamburg, Germany

The dynamic response of magnetic order to ultrafast external excitation is a fascinating field of modern research on magnetism. Optical probing at the femtosecond time scale allows the investigation of ultrafast magnetisation dynamics, including fundamental interactions between spins, electrons, and lattice degrees of freedom far from equilibrium. Despite the picosecond magnetisation dynamics, even for non-uniform states, has been successfully modelled with spatially averaged models, there is a growing understanding of the important role played by spatially-varying magnetisation. Particularly important is unravelling the non-equilibrium spin dynamics following laser excitation on the nanometer length scale where magnetic order emerges. Access to the nanometer length scale during the ultrafast processes has only recently been achieved thanks to the development of XFEL's and new detectors of scattered X-rays. So far, this opportunity has been implemented only in study of ultrafast dynamics of spatial magnetic fluctuations in ferrimagnets with perpendicular magnetic anisotropy. In the present work, we used XFEL to study spatially resolved ultrafast magnetic dynamics in ferromagnet that arises after femtosecond laser pumping.

The experiment was carried out at the SCS beamline of EuXFEL by resonant magnetic SAXS in transmission geometry with the use of DSSC detector. The photon energy was tuned to the L-edge of cobalt at 779 eV. A femtosecond IR laser with a wavelength of 800 nm was used for pumping. The main results were obtained on a (1.0 nm Co/1.2 nm Pt)₆ multilayered sample. The static SAXS pattern of the non-magnetised sample was dominated by the low-q third order scattering ring at $q \approx 0.07 \text{ nm}^{-1}$ corresponding to the maze-like multi-domain structure with domain size of about 60 nm. A sufficiently strong IR laser pulse was shown to cause an instant femtosecond-fast decrease of the low-q scattering followed by a picosecond-fast recovery. This is a known fingerprint of the ultrafast demagnetisation by IR radiation melting the magnetic domain order. Remarkably, for the IR fluences above 3.3 mJ/cm^2 , additional scattering on shorter length scales (at high $q > 0.8 \text{ nm}^{-1}$) appeared a few ps after the IR pulse. The re-formation and growth of magnetic order proceeds over picosecond time scales with a velocity in the km/s range. When a strong saturating field of 350 mT was applied, both static and transient low-q magnetic scattering completely vanished while the high-q transient magnetic scattering remained visible at a much lower level. This proves the magnetic nature of the observed transient effects.

The influence of the pump fluence and consequent sample heating have been investigated as the sample did not completely recover long range domain order during the $1.8 \mu\text{s}$ between the subsequent FEL pulses. This is an evidence of the quasi-static pulse-by-pulse increase of base temperature on the μs -timescale. As a consequence, the transient magnetic signal at large q being the highest during the first pumped frame, faded away as the system was heated and vanished after several FEL bunches.

To conclude, we have for the first time observed a very bright transient magnetic scattering taking place in thin Co/Pt multilayers upon femtosecond IR excitation. This transient scattering is coupled to the destruction of magnetic domain order and occurs shortly after on a few picosecond time scale.

Email of corresponding author: igor.pronin@mail.ioffe.ru

PETRA III and future outlook - PETRA IV

Christian G. Schroer for the PETRA III/IV group

DESY Photon Science, Notkestr. 85, 22607 Hamburg, Germany
Dept. of Physics, Universität Hamburg, Luruper Chaussee 149, 22761 Hamburg, Germany

PETRA III is DESY's brilliant synchrotron radiation source and is in operation since 2009. Also, in the past year, its active user community has performed many cutting-edge experiments and produced exciting scientific results. Some of these results will be highlighted in this presentation.

Since 2014 PETRA III has been extended, adding two new experimental halls and a number of new beamlines to the facility. Many of these beamlines have taken up user operation, others are currently in commissioning or under construction.



DESY plans to upgrade PETRA III to the ultra-low emittance source PETRA IV [1,2]. It will enable new groundbreaking studies in many fields of science and industry, such as health, energy, earth and environment, mobility, and information technology. Being diffraction-limited up to X-rays of about 10 keV, PETRA IV will be ideal for three-dimensional X-ray microscopy of biological, chemical, and physical processes under realistic conditions with highest resolution and sensitivity. In 2019, the conceptual design of the new facility was completed. In the next phase, the technical design will be developed.

[1] C. G. Schroer, et al., J. Synchrotron Rad. **25**, 1277–1290 (2018)

[2] PETRA IV Conceptual Design Report, DESY (2019), DOI: 10.3204/PUBDB-2019-03613

Email corresponding author: christian.schroer@desy.de

Structural insights into the multifunctional L protein of bunyaviruses

Nadja Gogrefe¹, Dominik Vogel¹, Juan Reguera², Stephen Cusack³, Stephan Günther¹,
Sophia Reindl¹, and Maria Rosenthal¹

¹ *Bernhard Nocht Institute for Tropical Medicine, Hamburg, Germany*

² *Aix-Marseille Université, CNRS, AFMB UMR 7257, 13288 Marseille, France*

³ *European Molecular Biology Laboratory, Grenoble, France*

Bunyaviruses are a diverse group of viruses distributed globally, causing severe human diseases, such as the Lassa fever. Therefore, several bunyaviruses are listed on the WHO R&D Blueprint, which has been established to enhance preparedness for future epidemics and urge for the development of medical countermeasures, such as antiviral drugs.

Bunyaviruses are RNA viruses with a single-stranded genome in negative polarity that infect cells and use the cellular metabolism to amplify. A key factor for bunyavirus genome replication and transcription is the large 250-450 kDa L protein, a multidomain and multifunctional viral protein. The L protein performs at least two different jobs: (1) amplification of the viral genome, a process referred to as genome replication, and (2) viral transcription, that is synthesis of viral mRNA which encodes information for the production of viral proteins at the host cell ribosomes. However, to access the cellular protein production machinery mRNA usually requires a specific modification – a cap-structure. As bunyaviruses do not possess enzymes to synthesise caps, they “steal” the cap-structures of cellular mRNA by a so-called cap-snatching mechanism. Cap-snatching involves both a cap-binding site, which binds to host capped mRNA, and an endonuclease, which cleaves the host RNA a few nucleotides downstream of the cap-structure. An RNA-dependent RNA polymerase then synthesises the viral mRNA using the capped host RNA fragment as a primer. The endonuclease and RNA-dependent RNA polymerase functions are located in different domains of the L protein. Even though bunyavirus endonuclease domains have been structurally and functionally well characterised, evidence for the second important protein activity for cap-snatching, the cap-binding function, was missing.

We used X-ray crystallography to determine structures of bunyavirus L protein fragments and were able to identify a cap-binding domain in bunyavirus L proteins. Structural comparison to the related influenza viruses, which share the cap-snatching mechanism as a strategy for viral mRNA synthesis, revealed striking similarities concerning the protein architecture despite a very low sequence similarity. The details of the cap-binding site however differ from that of influenza. In summary, the crystal structures we solved represent evidence for a cap-binding function in bunyavirus L protein, a new target for the development of antiviral compounds to fight bunyavirus infections.

Email of corresponding author: rosenthal@bnitm.de

Size induced Structural Changes in Molybdenum Oxide Nanoparticles

Troels Lindahl Christiansen¹, Espen D. Bøjesen², Mikkel Juelsholt¹, Joanne Etheridge² and Kirsten M.Ø Jensen¹

¹ *Department of Chemistry and Nanoscience Center, University of Copenhagen, 2100 Copenhagen Ø, Denmark*

² *Monash Centre for Electron Microscopy and Department of Material Science and Engineering, Monash University, Victoria 3800, Australia*

Small particles often show atomic structures different from the bulk material counterparts. These nanoscale atomic rearrangements can be utilised to tune materials properties; however, the nanostructures also pose a challenge to conventional structural characterisation techniques due to the small domain size and disordered nature. Structural characterisation is a critical part of materials development which makes the continual development of better tools for characterisation of structure on the nanoscale an important step in reaching the full potential of nanomaterials.

We have studied the atomic-scale structural changes occurring in MoO₂ nanoparticles at the nanoscale. Bulk MoO₂ adopts a distorted rutile structure; however, significant changes in the powder diffraction pattern of sub-10 nm particles indicate a fundamental structural rearrangement. In recent years total scattering and pair distribution function (PDF) analysis has emerged as a method for reliably characterising the atomic structure on the nanoscale, as it allows a direct view of the interatomic distances in a nanostructure. Utilizing the intuitive nature of the PDF method, we found that the structural changes relate to defects in the arrangement of the [MoO₆]-octahedra that make up the structure of MoO₂, and the octahedra show a larger tendency towards edge-sharing in the small particles. Similar crystallographic defects are known from bulk structures, and a simple model of the nanostructured MoO₂ is developed by applying these structural descriptions.

To achieve synthetic control of the defects in the MoO₂, we also studied the formation of MoO₂ *in-situ* using total scattering. In solution, molybdenum ions form a range of polyoxometalate ions, POMs, where [MoO₆] units are arranged in large, closed-shell clusters. Upon synthesis these break down to form the MoO₂ structures, and the POM may be considered pre-nucleation clusters. The nature of the POM present in solution is highly dependent on solvent properties, temperature and pH. By utilising this, we alter the prenucleation cluster structure, and in this way control the synthesis product to obtain both the pristine and highly defected MoO₂ structure. The differences in the structure of the products are linked to distinct reaction pathways from the clusters to the final product.

The studies highlight the value of PDF for nanostructural characterisation and obtaining information on the chemistry of nucleation. Greater understanding of nanomaterials' structure and chemistry will help to further develop nanomaterials as solutions to various challenges to society.

Email of corresponding author: troels@chem.ku.dk

Investigating Amphiphilic Monolayers with Grazing - Incidence Diffraction and X-ray Fluorescence

Emanuel Schneck

Department of Physics, Technische Universität Darmstadt

Soft interfaces constituted by molecular assemblies in two dimensions play key roles in numerous technological applications and are major components of all biological matter, for example in the form of biomembranes. The understanding of important biological or technological processes involving such interfaces typically relies on detailed structural insight.

We use various synchrotron-based X-ray diffraction and X-ray fluorescence techniques for the comprehensive characterisation of amphiphilic layers in terms of in-plane structural organisation, density profiles, elemental distributions, surface charge, and specific interactions with ions.

Email of corresponding author: schneck@fkp.tu-darmstadt.de

Direct Imaging of Orbitals in Quantum Materials

Liu Hao Tjeng

Max Planck Institute for Chemical Physics of Solids, Nöthnitzerstr, 40, 01187 Dresden, Germany

The search for new quantum materials with novel properties is often focused on materials containing transition-metal and/or rare-earth elements. The presence of the atomic-like d or f orbitals provides a fruitful playground to generate new phenomena. The intricate interplay of band formation with the local correlation and atomic multiplet effects leads to phases that are nearly iso-energetic, making materials' properties highly tunable by doping, temperature, pressure or magnetic field. Understanding the behavior of the d and f electrons is essential for designing and controlling novel quantum materials. Therefore, identifying the d or f orbitals that actively participate in the formation of the ground state is crucial. So far, these orbitals have mostly been deduced from optical, X-ray and neutron spectroscopies in which spectra must be analysed using theory or modelling. This, however, is also a challenge in itself, since *ab-initio* calculations hit their limits due to the many-body nature of the problem.

Here we developed a new experimental method that circumvents the need for involved analysis and instead provides the information as measured. With this technique, we can make a direct image of the active orbital and determine what the atomic-like object looks like in a real solid. The method, s -core-level non-resonant inelastic X-ray scattering (s -NIXS), relies on high momentum transfer in the inelastic scattering process, which is necessary for dipole-forbidden terms to gain spectral weight. To demonstrate the strength of the technique, we imaged the text-book example, $x^2-y^2/3z^2-r^2$ hole orbital of the Ni^{2+} ion in NiO single crystal [1], see Fig. 1. We will present the basic principles of s -NIXS and its experimental implementation. We will also show how we can apply this technique to unveil the active orbitals in complex oxides such as $\text{Ca}_3\text{Co}_2\text{O}_6$ [2], as well as to determine the orbital character in highly metallic systems such as elemental Cr, Fe, and Ni.

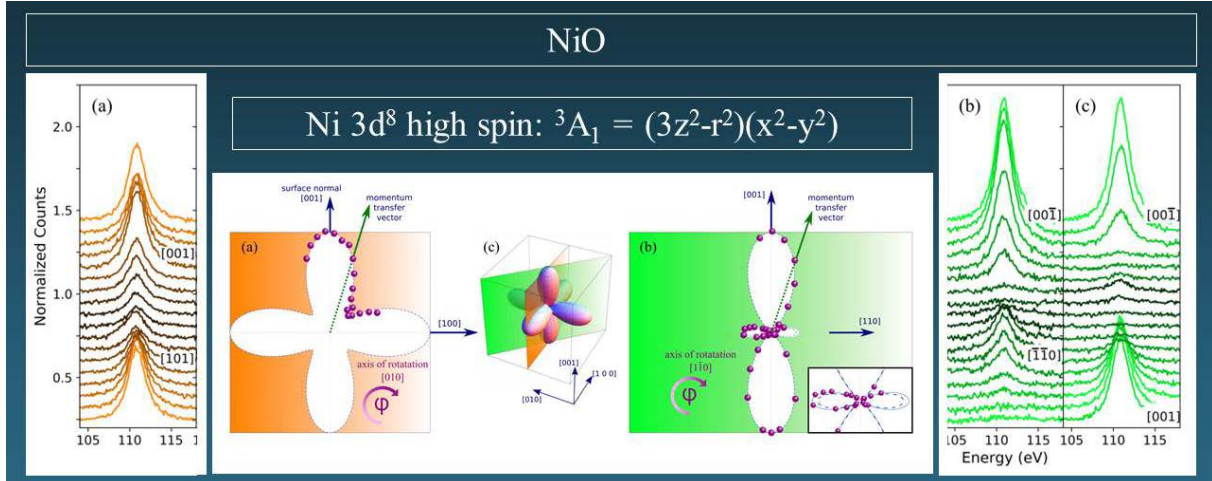

Fig. 1: Directional dependence of the spectral intensity associated with the dipole forbidden $3s \rightarrow 3d$ transition directly maps the local hole charge distribution.

- [1] H. Yavaş, M. Sundermann, K. Chen, A. Amorese, A. Severing, H. Gretarsson, M.W. Haverkort, L.H. Tjeng, *Nature Physics* 15, 559 (2019); <https://doi.org/10.1038/s41567-019-0471-2>.
[2] B. Leedahl, M. Sundermann, A. Amorese, A. Severing, H. Gretarsson, L.-Y. Zhang, A.C. Komarek, A. Maignan, M.W. Haverkort, and L.H. Tjeng, *Nature Communications* 10, 5447 (2019); <https://doi.org/10.1038/s41467-019-13273-4>.

Email of corresponding author: hao.tjeng@cpfs.mpg.de

II Programmes Satellite Meetings

SATELLITE WORKSHOP - Photon Science



Static Pressure Experiments at XFEL

27– 28 Jan.2020

DESY, FLASH Sem.R., Bldg. 28c

In October 2019 more than 70 scientist of the high pressure community from 7 nations collaborated in a community-assisted commissioning beamtime to develop a platform for high pressure experiments in the Diamond Anvil Cell at the High Energy Density (HED) Instrument of the European XFEL. The group benchmarked the capability of generating and probing extreme states using Diamond Anvil Cells, safely studying samples to pressures exceeding 1 Mbar. During the beamtime the group commissioned and tested the DAC setup in the 2nd interaction chamber (IC2) of the HED instrument in conjunction with a VAREX flat panel detectors in order to collect time-integrated diffraction images from samples exposed to femtosecond X-ray pulses at MHz repetition rates, to experimentally explore some crucial aspects of XFEL DAC science such as e.g. diamond stability and X-ray heating using 17.8 keV XFEL. In this workshop we will discuss not only the our findings from the October experiment but also give an overview of all DAC at XFEL experiments as well as the plans for the near future for DAC work at HED in IC2 and IC1.

Organisers: H. P. Liermann and Z. Konopkova

Contact: hanns-peter.liermann@desy.de,
zuzana.konopkova@xfel.eu

PROGRAM (27 Jan. 2020)

13:00	Welcome	C. Strohm	DESY
	Session 1: Introducing DAC at XFELs Experiments		Chair: Z. Konopkova
13:05	DAC Diffraction Experiments at XFELs: New Opportunities	H. P. Liermann	DESY
13:30	First DAC Experiments at PAL	A. Coleman	LLNL
13:55	Probing the electronic spin crossover in Fe-compounds at HED: new frontiers for high pressure science using the EuXFEL	V. Cerantola	XFEL
	Session 2: DAC Setup at IC2 of the HED Instrument		Chair: C. Strohm
14:20	DAC Alignment and X-ray Diffraction Capabilities of the IC2 at HED (EuXFEL)	C. Prescher	DESY
14:45	SOP Temperature Measurements in IC2	Z. Konopkova	XFEL
	Session 2: Diffraction and X-ray Heating of Metal Foils using 17.8 keV X-ray of the EuXFEL		Chair: E. McBride
15:15	Metal Foil Array Measurements at very low Pressures	M. McMahon	Uni. of Edinburgh
15:15-16:00	Coffee break and Posters (45 Min.)		
16:00	Fe and Fe alloys Experiments	G. Fiquet	IMPMC
16:25	Ta Experiments	Z. Jenei	LLNL
16:50	Melting of Mo at high pressures induced by intense X-ray pulses	C. Prescher	DESY
17:15	Au Experiments from PAL and at EuXFEL	R. Husband	DESY
17:40	Thermally-induced, quenchable bcc Zr using the European XFEL	B. Sturtevant	LANL
18:05	Reaction of W with H evidenced by Eu-XFEL	J. Kim	Hanyang Uni.
18:30	Comparison of T estimates from X-ray data (EOS) and SOP	St. McWilliams	Uni. of Edinburgh
19:00	End of the 1st day (self-payd dinner) TBD		

PROGRAM (28 Jan. 2020)

9:00	Announcements		Institution
	Session 3: Future Proposed Experiments at the HED instrument		Chair: St. McWilliams
9:10	Single shot heating experiments, using pulsed laser or X-ray, in the DAC for MHz diffraction.	G. Morard	IsTerre
9:20	X-ray Heating of low-Z Materials at High Static Pressures	M. McMahon	Uni. of Edinburgh
9:30	Kinetics of structural phase transition in the dynamic-diamond anvil cell (dDAC): bridging static and shock compression	H. P. Liermann	DESY
9:40	Spin states of FeS and (Mg,Fe)O by X-ray emission at HED	Ch. Sternemann	TU Dortmund
9:50-10:30	<i>Coffee break and Posters (40 Min.)</i>		
10:30	Getting Ready for Proposed Experiments	C. Strohm, K. Appel	DESY
11:00	Close Out Discussion	St. McWilliams	Uni. of Edinburgh
11:30	Travel to EuXFEL for HED Satellite Meeting		



User experience of data analysis at European XFEL

Tuesday 28 January 2020

DESY, CSSB lecture hall, Auditorium, Notkestraße 85, 22607 Hamburg

This community driven satellite workshop is focused on sharing user experience from users with users. The event is split into two short sessions on the topics of (i) online data analysis and (ii) offline data analysis and data reduction. This is complemented with opportunities to network through informal exchanges.

Both sessions of about 45 minutes are planned to start with three very brief presentation from users to kick start the discussions, who will use 3-slide presentations each to summarise the what, how and why of their specific data analysis at EuXFEL.

We invite all users to share their experience through participation in subsequent discussions. The remaining time is scheduled for questions and answers between presenters and audience. Future users are of course welcome to attend the event as well.

The emphasis of the event is on exchanging data analysis experience from using European XFEL to avoid duplication of effort, establish and share best practice, and for European XFEL to seek guidance on the community's wishlist for continued, improved and new services.

The workshop starts at 14:00 and concludes with an open ended coffee and networking session from approximately 15:40 onwards.

Organizers: Fabio Dall'Antonia,
Hans Fangohr

Contact: fabio.dall.antonio@xfel.eu
Contact: hans.fangohr@xfel.eu

Tuesday 28 January 2020 – DESY, CSSB Lecture theatre (Bldg. 15)			
14:00	Welcome	Steve Aplin	European XFEL
14:10	Session 1 – online analysis		
		Valerio Mariani	CFEL
		Clemens Prescher	DESY
		Philipp Schmidt	European XFEL
14:55	Session 2 – offline analysis and data reduction		
		Filipe Maia	Uppsala University
		Oleksandr Yefanov	CFEL
		Michael Schneider	MBI Berlin
15:40	Coffee, networking and close		

European XFEL Users' Meeting — Satellite meeting

First experiments with a high-intensity short-pulse laser at HED/HIBEF

Mon. 27-28 January 2020 / Room: XTOB 1.01
European XFEL, Holzkoppel 4, 22869 Schenefeld



The main goal of this workshop is to inform potential future users of the current development status of the high-intensity short-pulse laser commissioning at the HED instrument and discuss early user experiments. These include the High Intensity (~100 TW) laser (HIBEF/Amplitude) and the Pump-Probe laser (EuXFEL) systems. Summary and feedback to the previous 2017 workshop will be given. The workshop provides ample time for open discussion.

Organizer: Toma Toncian and Motoaki Nakatsutsumi
Contact: toma.toncian@xfel.eu, motoaki.nakatsutsumi@xfel.eu

Mon. 27 Jan 2020 – EuXFEL XTOB 1.01

13:30	Welcome	T. Cowan (tbd)	HZDR
13:40	Summary of the last workshop “High Intensity Laser Matter Science at the HED Instrument at the European XFEL” in 2017. Desires and requirements.	T. Toncian M. Nakatsutsumi	HZDR European XFEL
14:10	Status of the instrument	Chair: M. Nakatsutsumi	
14:10	Overview and status of the HED instrument	T. Preston	European XFEL
14:30	Status of the high-intensity 100 TW laser	T. Toncian	HZDR
14:50	Status of the online timing tool	J-P. Schwinkendorf	European XFEL
15:00	Status of the pump-probe (PP) laser	J-P. Schwinkendorf	European XFEL
15:10	Coffee		
15:40-16:45	Roadmap towards standard setups	Chair: T. Toncian	
15:40	Small angle X-ray scattering	M. Smid	HZDR
15:55	Polarimetry (recent XFEL experiment)	H-P. Schlenvoigt	HZDR / Jena
16:20	Phase contrast imaging (PCI) / nano-focusing	M. Makita	European XFEL
16:35	Fast sample scanner, robotic arm	M. Makita	European XFEL
16:45	EMP – current challenge and plans	S. Göde	European XFEL
16:55	Small break		
17:10	Recent experiments	Chair: A. Pelka	
17:10	Resonant SAXS experiment at LCLS	T. Kluge	HZDR
17:25	Small Angle X-ray Scattering on Rod Assembly Target at SACLA	M. Ota	U. Osaka, Japan
17:40	Overview of short-pulse laser experiments at LCLS	M. Gauthier/ C. Curry	LCLS
17:55	GISAXS experiment at SACLA	M. Nakatsutsumi	European XFEL
18:10	Open discussion	Chair: U. Zastra	
18:30	Dinner Buffet at BeamStop Restaurant		

Tue. 28 Jan 2020 – EuXFEL XTOB 1.01

9:30	Open discussion	Chair: T. Toncian and M. Nakatsutsumi (tbd)	HZDR European XFEL
	Preparation for the first-day experiments		
	Community proposal		
11:30	Final remarks, closing of the workshop		
12:00	Lunch at BeamStop Restaurant		

European XFEL Users' Meeting — Satellite meeting

Chemical Dynamics Opportunities at the Scientific Instrument FXE



28 January 2020

European XFEL, Holzkoppel 4, 22869 Schenefeld and
DESY, CFEL SemR I-III, Notkestraße 85, 22607 Hamburg

Abstract:

The Femtosecond X-Ray Experiments (FXE) Instrument has recently taken large steps towards experiments for time-resolved x-ray emission (XES) and wide-angle scattering (WAXS) studies. The instrument can now host experiments, which demand an unprecedented high average flux and signal quality, possible due to the MHz delivery rate of 2-4 mJ X-ray pulses. The current status of the FXE will be given together with its upcoming capabilities.

This workshop seeks to bring together the scientific community aiming to exploit this instrument for chemical dynamics research benefiting from the spin and electronic sensitivity delivered from XES data, and from structural dynamics studies exploiting WAXS at up to 20 keV. The workshop will cover variety of topics in photochemistry, which can benefit for the simultaneous determination of coupled electronic and geometric transient structure changes on femtosecond time scale.

Organizers: Christian Bressler
Wojciech Gawelda
Dmitry Khakhulin

Contact: christian.bressler@xfel.eu
wojciech.gawelda@xfel.eu
dmitry.khakhulin@xfel.eu

Tuesday 28 January 2020 – DESY, CFEL Sem.R. I-III (Bldg. 99)

09:00	Welcome	Sakura Pascarelli	European XFEL
09:15	FXE instrument update	Dmitry Khakhulin	European XFEL
09:45	Spin cross-over dynamics in biology and condensed matter	Majed Chergui	EPFL, Switzerland
10:10	Visualizing the ultrafast spin-dynamics in photoexcited Nickel tetrapyrroles	Sophie Canton	ELI-Alps, Hungary DESY, Germany
10:35	Coffee break		
11:00	Ultrafast X-ray spectroscopy to understand the photochemistry of base metal complexes	Matthias Bauer	University of Paderborn, Germany
11:25	Tracking coherent structural dynamics in solvated metal complexes	Martin M. Nielsen	DTU, Denmark
12:00	Lunch at DESY Restaurant		
13:30	Solving chemical processes dynamics with X-ray spectroscopy	Jacinto Sa	Uppsala University, Sweden
13:55	Luminescent 3d ⁶ and 4d ⁶ metal complexes made from Earth-abundant elements as alternatives to non-emissive Fe(II) compounds	Oliver Wenger	University of Basel, Switzerland
14:20	Tuning Ligand-Environments for the Stabilization of Iron Complexes in Oxidation States +I to +V, including Spin-Crossover in 4-Coordinate Fe(II)	Karsten Meyer	Friedrich Alexander University, Erlangen, Germany
14:45	Tracking reaction intermediates in catalytic reactions relevant to molecular artificial photosynthesis	Antoni Llobet	ICIQ, Spain
15:10	Coffee break		
15:30	Ultrafast, fast and slow structural changes of photoactive orange carotenoid protein during its photocycle	Eugene Maksimov	Moscow State University, Russia
15:55	Spinflip in chromium and vanacomplexes	Katja Heinze	Johannes Gutenberg University, Mainz, Germany
16:20	Discussion Round	Christian Bressler	European XFEL
17:00	Bus transport to European XFEL		
17:30	Tour of FXE Instrument	all	
18:30	Dinner at <i>BeamStop</i> Restaurant (at EuXFEL)	all	



MID Workshop: First year of operation and future developments

Mon 27 - Tue 28 January 2020 / Room: XHQ E1.173
European XFEL, Holzkoppel 4, 22869 Schenefeld

The workshop is addressing the very first user experiments at the Materials Imaging and Dynamics (MID) instrument performed from March to November 2019. A status report of MID will be given together with selected presentations from user groups that span a diverse set of scientific topics, experimental techniques, and beam parameters. New equipment arriving at the instrument in 2020 will be discussed, e.g. a synchronized optical fs laser for pump-probe experiments and an X-ray split-delay line for XPCS applications. Together with developments of the source this will further broaden the scientific scope and strengthen the capabilities of MID.

Organizer: Anders Madsen

Contact: anders.madsen@xfel.eu

Mon. 27 Jan 2020 – EuXFEL XHQ E1.173

13:30	Welcome	Sakura Pascarelli	European XFEL
13:40	MID status	Anders Madsen	European XFEL
<i>Session I. Chair: U. Boesenberg, European XFEL</i>			
14:20	Single pulse holographic imaging at MID	Johannes Hagemann	DESY
14:55	Evaporating laminar jets at XFELs for studies of crystal nucleation and growth in supercooled atomic liquids	Robert Grisenti	Uni. Frankfurt
15:30	Wavefront characterization using ptychography	Benedikt Daurer	National Uni. Singapore
16:05	Coffee break		
<i>Session II. Chair: J. Möller, European XFEL</i>			
16:25	New emerging possibilities at MID	Jörg Hallmann	European XFEL
17:00	Detector challenges in fast XPCS experiments	Christian Gutt	Uni. Siegen
17:35	High intensity with extreme focusing	Saša Bajt	DESY
18:10	Discussion and wrap up		
18:30	Dinner Buffet at BeamStop Restaurant		

Tue. 28 Jan 2020 – EuXFEL XHQ E1.173

<i>Session III. Chair: A. Zozulya, European XFEL</i>			
9:30	Ultrafast X-ray photon correlation spectroscopy using hard X-ray split-and-delay line at FELs	Wojciech Roseker	DESY
10:05	Time resolved Bragg coherent diffraction imaging and fluctuation spectroscopy of oxide thin films	Ian Robinson	BNL & UCL
10:40	Collective radiative processes induced by the interaction of XFELs with matter	Andrei Benediktovitch	CFEL
11:15	Coffee break		
<i>Session IV. Chair: A. Madsen, European XFEL</i>			
11:35	Probing inhomogeneous structural dynamics and dynamic heterogeneity with LCLS-II	Diling Zhu	SLAC
12:10	Discussion, feedback and summary		
13:00	Lunch		
14:00	MID instrument visit (optional)		

European XFEL Users' Meeting — Satellite meeting:
Current status and future completion at the HED instrument and the HIBEF contributions



28. Jan. 2020 / XHQ E1.173
 European XFEL, Holzkoppel 4, 22869 Schenefeld

The half-day workshop on the HED instrument and the HIBEF User Consortium will take place in the large seminar room E1.173 at the European XFEL headquarter building in Schenefeld. You will hear status updates of different experimental setups, which came online in the last month, and perspectives of the HED instrumentation also in view of beamtime application for upcoming runs. After a coffee break, the second part of the afternoon will concentrate on HiBEF UC contributions with special emphasis on the High-Energy laser DIPOLE, which will be installed and commissioned in 2020, and diagnostic tools used in shock compression experiments. In addition, status of the TW laser and planned first commission experiments will be represented. We plan for a reception in the “BeamStop” in the evening.

Organiser: Ulf Zastrau, Carsten Baetz
 Contact: ulf.zastrau@xfel.eu, carsten.baetz@xfel.eu

Tue. 28 January 2020 – EuXFEL XHQ E1.173			
13:30-16:00	User operation at HED		
13:30	Status of HED in 2019	U. Zastrau	European XFEL
14:00	Resolving low-frequency structural dynamics at the HED scientific instrument	L. Wollenweber	European XFEL
14:20	Simultaneous high pressure and high temperature XES and XRD measurements at HED	J. Kaa	European XFEL
14:40	Focus characterization in IC 1	M. Makita	European XFEL
15:10-15:30	<i>Coffee break</i>		
15:30-19:00	General HIBEF UC assembly		
15:30	Status of the HIBEF project	T. Cowan	HZDR
16:00	Dipole	T. Butcher	STFC
16:20	HIBEF contributions from LANL	C. Bolme	LANL
16:40	New VISAR at LULI 2000	L. Meignien	LULI
17:00	XANES at XFELs	M. Harmand	IUPMC
17:20	High-precision x-ray polarimetry at HED	K.S. Schulze	HIJ
17:40	Summary of the High-Intensity Laser experiments workshop	T. Toncian	HZDR
17:50	Route map to first DIPOLE experiments	M. McMahon	Edinburgh
18:30	<i>Light dinner in Beamstop</i>		



1st meeting of the European XFEL Spanish user community

Thursday 30 January 2020

DESY, EMBL SemR, Bldg. 48e, Notkestraße 85, 22607 Hamburg

Abstract: This meeting intends to gather for the first time the Spanish community of European XFEL users, current and prospective, to discuss and identify common scientific interests and research lines. The synergy with the existing national user facilities and research centers as well as the development of strategies to facilitate the access to EuXFEL will be discussed

Organizer: Manuel Izquierdo
Wojciech Gawelda

Contact: manuel.izquierdo@xfel.eu
wojciech.gawelda@xfel.eu

Thu. 30 January 2020 – DESY, Building 48e EMBL Seminar room L202

14:00-14:05	Welcome	-	Spanish Government
14:05-14:15	The Spanish Community at EuXFEL	Robert Feidenhans'l	European XFEL
Part I: Proposed experiments at EuXFEL			
14:15-14:40	Simultaneous probing of electronic correlations and structural changes during the ultrafast photodissociation of manganese carbonyl in solution	Luis Bañares	Universidad Complutense Madrid
14:40-15:05	Perspectives for Macromolecular Crystallography at X-ray Free Electron Lasers	Jose Martin-Garcia	Arizona State University
15:05-15:30	Time dependent atomic physics with non-thermal electron population for isochorically heated matter	Pedro Velarde	Universidad Politécnica Madrid
15:30-15:55	Stimulating the signal of Atom Mixing induced by Majorana neutrinos	Alejandro Segarra	Instituto Fisica Corpuscular Uni-Valencia-CSIC
15:55-16:10	Coffee Break		
Part II: Scientific perspectives			
16:10-16:35	Attosecond core-level spectroscopy - lightwave driven dynamics in condensed phase	Jens Biegert	ICFO - Institute of Photonics Science
16:35-17:00	Attosecond molecular dynamics with XFELs, a theoretical perspective	Fernando Martin	Universidad Autonoma Madrid
17:00-17:25	Artificial Photosynthesis: From solution to surfaces	Rodolfo Miranda	IMDEA Nanoscience Madrid
17:25-17:50	Time-resolved photoemission spectroscopy at FLASH and EuXFEL	Kai Rossnagel	Universität Kiel & FS-SXQM, DESY
17:50-18:00	Short Break		
Part III: Spanish Photon Science User Facilities			
18:00-18:25	VEGA, the Spanish High Repetition Rate Petawatt System	Luis Roso	Spanish Center for Pulsed Lasers - CLPU
18:25-18:50	The art to understand dynamics	Klaus Attenkofer	ALBA Synchrotron
Part IV: Discussion			
18:50-19:10	Strategies to develop Spanish EuXFEL		
19:10	Dinner at DESY Canteen (UM2020 reception)		

SATELLITE WORKSHOP - Photon Science



Coherent X-ray scattering and imaging

30. Jan. 2020

CFEL I-III, Bldg. 99 &
SemR FLASH, Bldg 28c

New coherent x-ray scattering techniques have been developed, implemented and exploited at several instruments of PETRA III. These instruments use forward or Bragg scattering geometries or apply nano-focusing capabilities as e.g. provided by the P10-GINIX (build by the group of Prof. T. Salditt).

This workshop aims to give a comprehensive overview of available research opportunities / activities employing coherent X-rays.

The first part of this satellite workshop will be shared with the "10th workshop on X-ray Nano-Imaging of Biological and Chemical Systems at PETRA III" and present highlight results of different imaging approaches. The 2nd half of the satellite workshop will present the current state of the P10 beamline followed by presentations covering recent research activities.

Organizers: I. Vartaniants,
M. Sprung

Contact: ivan.vartaniants@desy.de,
michael.sprung@desy.de

PROGRAMME (Session I: CFEL I-III)

Session 1: Nano-imaging and P10 workshop session		Chair: G. Falkenberg	
13:00	Welcome & X-Ray Microscopy Today and at PETRA IV	Christian Schroer.	DESY / UHH
13:20	News from the Nanolab	Thomas Keller.	DESY
13:30	Sample cells for X-ray ptychography and nanotomography - towards operando chemical imaging of catalysts and functional materials	Thomas Sheppard	Karlsruhe Institute of Technology
14:00	Multi-scale tomography of heart tissue: from Cardiomyocyte to whole heart	Marius Reichardt	University of Göttingen
14:30	Revealing the organization of axonal bundles from synchrotron tomography using streamline tractography	Hans Martin Kjer	Technical University of Denmark
15:00	3D anatomy and spatial chemistry in animal-microbe symbioses – Correlative phase-contrast x-ray tomography, metabolite imaging and fluorescence microscopy	Benedikt Geier	MPI Marine Microbiology

15:30-
16:00 **Coffee break (30 Min.)**

Session 2: Opportunities @ P10		Chair: I. Vartaniants	
16:00	News/Updates from P10	Michael Sprung/ Markus Osterhoff Hendrik Rahmann	DESY/ University of Göttingen University of Siegen
16:20	Dynamics of liquid-liquid phase separation in protein solutions studied by low radiation dose XPCS		
16:40	X-ray induced dynamics in oxide glasses probed at inter-atomic length-scales	Francesco Dallari	University of Trento/DESY
17:00	Evolution of the strain field in Pt nanoparticles during CO oxidation using Bragg coherent imaging	Maxime Dupraz	ESRF/CEA
17:20	Correlation between Conductivity and Structure revealed by AXCCA in PbS Nanocrystal Superlattices	Dmitry Lapkin	DESY
17:40	Structural study of a single Au grain mesocrystal by Coherent X-ray Diffraction Imaging	Jerome Carnis	DESY
18:00	PETRA IV coherence properties	Ruslan Khubbutdinov	DESY
18:20	Closing remarks	Ivan Vartaniants/ Michael Sprung	DESY

18:25 **End of the workshop**



Central infrastructure for DESY Photon Science Scientific computing - update and future directions

30 Jan. 2020

SemR BAH1/BAH2, Bldg. 3

This satellite workshop addresses the increasing demand for cooperation between central IT and DESY Photon Science in the field of scientific computing. It will give an update on work done in the previous years, solutions and practices at DESY today, and future plans and directions to address coming challenges including the coming needs of PETRA IV

Organiser: Anton Barty, Martin Gasthuber, Andre Rothkirch Contact: martin.gasthuber@desy.de

PROGRAMME

14:00	Welcome and Introduction	Martin Gasthuber	DESY
14:15	Infrastructure update/news	Sven Sternberg	DESY
14:45	Analysis Services & Tools	Frank Schluenzen	DESY
15:05	HiDRA update and new developments	Manuela Kuhn	

15:30-16:00 Coffee break (30 Min.)

16:00	Real-time streaming data analysis using ASAPO	Sergey Yakubov, Tim Schoof	DESY
16:40	Machine Learning - ongoing and future projects	Frank Schluenzen, Philipp Heuser	DESY
17:20	Answers to collected questions & discussion		

18:30 *End of the workshop*



ECB Workshop

30.01.2020

Seminar room 3, Bldg. 1b

Description of workshop

In 2019 high-pressure research at the Extreme Conditions Beamline (ECB, P02.2) has continue to evolve. Experiments in the dynamic Diamond Anvil Cell at high-P have become a standard technique and the development of the simultaneous high-P and -T dDAC technique has further matured. We have also made progress in the development of imaging capabilities of the beamline, as well as in the calibration our standard resistive heated DAC setup together with our external partners. Submicron focusing is also becoming more robust and finds more and more users for ultra-high-pressure experiments. During this satellite meeting we will present ongoing research from different internal and external groups at the ECB and give an outlook on ongoing and foreseen technical developments.

Organizer: H. P. Liermann

Contact: hanns-peter.liermann@desy.de

PROGRAMME

			Chair: K. Glazyrin
14:00	Session 1: Experimental Capabilities of the ECB Status of the ECB and Outlook	H. P. Liermann	DESY
			Chair: H. P. Liermann
14:30	Session 2: Experimental highlights Multi-megabar diffraction studies at the ECB: toroidal DACs with submicron beam	E. Pace	Uni. of Edinburgh
15:00	Towards understanding kinetics on fast compression in the dynamic-DAC	R. Husband	DESY/LLNL
15:00-15:30	Coffee break (30 Min.)		
15:30	Radial diffraction in the dynamic DAC	L. Q. Huston	LANL
16:00	Time-resolved X Ray Diffraction experiments with a Resistively Heated dynamic Diamond Anvil Cell (RHdDAC)	A. Mendez	DESY/Uni. of Bayreuth
16:30	The "shocking" effects of dynamic compression and heating experiments on quartz	C. Otzen	DESY
17:00	Kinetics of Deformation at high Compression Rates using dynamic Diamond Anvil Cell.	Ch. Plueckthun	XFEL
17:20	Revisiting the spin state crossover in single crystal (MgFe)O at the regime of high resolution	K. Glazyrin	DESY
17:50	Crystal chemistry of Fe-rich bridgmanite at lower mantle pressures	J. Koemets	Uni. of Bayreuth
18:20	End of the workshop		



High Energy X-ray Diffraction for Physics and Chemistry

Thursday, 30 January 2020

CFEL, SemR IV, Bldg. 99

High energy X-ray diffraction and scattering based techniques have a unique impact in physics, chemistry, and materials science. In particular, they enable complex in situ and operando experiments and the analysis of local disorder on an atomic scale. This workshop brings together experienced users, interested researchers, and beamline staff. We are going to present and discuss the current and future capabilities available at the high-energy beamlines P07-DESY and P21.1 as well as key experiments that demonstrate the potential of these technique

Organizers: Ann-Christin Dippel, Martin v. Zimmermann

Contact: ann-christin.dippel@desy.de
martin.v.zimmermann@desy.de

PROGRAMME

14:00 Session 1

14:00	Status High Energy X-ray Diffraction Station P07-DESY	Ann-Christin Dippel	DESY
14:30	Status Broad Band Diffraction Beamline P21.1	Oleh Ivashko	DESY
15:00	Phase transformations in the nanowires of thiourea precursor of copper sulfide	Abhisakh Sarma	DESY

15:30-16:00 Coffee break (30 Min.)

Session 2

16:00	Spatially Inhomogeneous Competition between Superconductivity and the Charge Density Wave in $\text{YBa}_2\text{Cu}_3\text{O}_{6.67}$	Jaewon Choi	University of Zurich
16:30	In-situ and operando high-energy grazing incidence X-ray diffraction	Vedran Vonk	DESY Nanolab
17:00	Structure-property relations from thermal diffuse scattering	Björn Winkler	University of Frankfurt
17:30	Discussion		

18:00 End of the workshop



Interfaces in electro chemistry, corrosion and solution based self assembly

Thursday, 30. 01. 2020

SemR. 109, Bldg. 25b

The goal of this meeting is to elucidate the role of interfaces in the fields of electrochemistry, corrosion and solution based self assembly, with special focus on their investigation by state-of the art x-ray diffraction and spectroscopy, as well as complementary methods. The DESY NanoLab opens a new electrochemistry and liquid interfaces lab for DESY Photon Science users, which will be presented during the workshop. Among a number of invited talks, interested participants is given to opportunity to present their work.

Organisers: Andreas Stierle, Olaf Magnussen, Bridget Murphy

Contact: andreas.stierle@desy.de

PROGRAMME

14:00	Introduction	Andreas Stierle	DESY, FS-NL
14:05	Operando Insight into Structure, Composition and Reactivity Correlations in the Electrochemical Reduction of CO ₂	Beatriz Roldan	FHI Berlin
14:35	Electrochemical surface science of platinum	Marc T.M. Koper	Leiden University
15:05	In-Situ Stability Studies of IrO ₂ -based model Electrodes under OER Conditions	Herbert Over	Universität Gießen
15:45	The brightest Au(111) surface	Edvin Lundgren	Lund University
15:30-16:10	Coffee break (30 Min.)		
16:10	Observing Pt(111) under operando oxygen reduction and evolution conditions	Leon Jacobse	DESY FS-NL
16:30	Passive film on super duplex stainless steel and its electrochemical stability studied by synchrotron X-ray technique	Jinshan Pan	KTH Stockholm
16:50	Inspirations from interface and corrosion science: Strategies toward design of interface-controlled materials	Nadiia Mameka	HZG
17:20	Understanding liquid structure and dynamics interfaces at LISA	Bridget Murphy	Universität Kiel
17:40	In situ study of the formation mechanism of two-dimensional superlattices from PbSe nanocrystals	Oleg Konovalov	ESRF
18:10	Layer by layer growth of semiconductor thin films: an operando SXRD study	Francesco Karla	Diamond Light Source
18:30	End of the workshop		

SATELLITE WORKSHOP - Photon Science

Helmholtz-Zentrum Geesthacht GEMS Outstation: Materials Research and High Resolution Imaging

Thursday, 30 January 2020

DESY Auditorium, Bldg. 5

Helmholtz-Zentrum Geesthacht operates the research platform GEMS with an outstation at DESY, running beamlines and instruments with a focus on engineering materials research and high resolution imaging techniques. On the 2020 satellite meeting, the status of the HZG beamlines and future perspectives are reported and users will present recent research highlights.

Organisers: C. Krywka
P. Staron

Contact: christina.krywka@hzg.de
peter.staron@hzg.de

PROGRAMME

Session 1: Imaging			
14:00	Imaging instruments at IBL, HEMS and MINAXS	Christina Krywka	Chair: C. Krywka Helmholtz-Zentrum Geesthacht
14:15	Multimodal assessment of biodegradable Magnesium-based implants in bone	Berit Zeller-Plumhoff	Helmholtz-Zentrum Geesthacht
14:40	X-ray phase contrast Tomography for studying the Central Nervous System	Michela Fratini	CNR-Nanotec, La Sapienza University
15:05	Combined Diffraction Tomography and Fluorescence Tomography for spatially mapping elements in biological fiber reinforced nanocomposites	Paul Zaslansky	Charité - Universitätsmedizin Berlin Department for Operative and Preventive Dentistry
15:30 Coffee break			
Session 2: Diffraction			
16:00	Status of the diffraction beamlines	Norbert Schell	Chair: L. Lottermoser Helmholtz-Zentrum Geesthacht
16:15	FlexiDS – In-situ studies of directional solidification	Camelia Gombola	KIT, Inst. f. Angewandte Materialien
16:40	Hot forging wire and arc additive manufacturing	Joao Pedro Oliveira	NOVA University of Lisbon, Dep. Mech. & Industr. Eng.
17:05	Residual stresses in friction surfacing of Ti and Al alloys	Gleb Dovzhenko	Helmholtz-Zentrum Geesthacht
17:30 Final discussion			



Light-Matter Interaction: Recent Advances in Theory

Thursday, 30 January 2019

CFEL, SemR V, Bldg. 99

The meeting will comprise 6 talks on the respective theory advances in atomic, molecular, solid state physics, warm-dense-matter and plasma research. Participation will be open to all interested users of photon science facilities, attending the EuXFEL and DESY Photon Science Users' Meetings.

Organisers: Beata Ziaja-Motyka (Executive), Sang-Kil Son, Ralph Welsch & Robin Santra (CFEL-DESY Theory Group)

Contact: beata.ziaja-motyka@cfel.de

PROGRAMME

14:00	'Welcome Address'	Beata Ziaja-Motyka	CFEL, DESY Hamburg
14:15	'Strong-field control in the XUV domain'	Ulf Saalmann	MPIPKS, Dresden
14:45	'Polaritonic chemistry and materials: changing properties of matter by engineering the photon vacuum'	Michael Ruggenthaler	CFEL, MPSD, Hamburg
15:15	'Electron decay mediated charge redistribution in clusters'	Kirill Gokhberg	Univ. of Heidelberg
15:45	Coffee break (30 Min.)		
16:15	Session 2 (Chairman: Ralph Welsch, CFEL, DESY)		
16:15	'Free electron degeneracy in collisional-radiative simulations'	Howard Scott	LLNL, USA
16:45	'Essentially Exact Molecular Dynamics with Quantum Chemistry and Machine Learning'	Alexandre Tkatchenko	Univ. du Luxembourg
17:15	'New insights into nonlinear optical response with x-rays'	Daria Gorelova	CFEL, DESY, Hamburg
17:45	'Closing Remarks'	Robin Santra	& Univ. of Hamburg CFEL, DESY Hamburg
18:00	End of the workshop		

SATELLITE WORKSHOP - Photon Science



High-pressure Science in the Large Volume Press at P61B

30.01.2020

SemR 456, Bldg. 25f

Studies on mm-sized samples at high pressures (and temperatures) in the Large Volume Press using *in situ* X-ray techniques are now possible at beamline P61B. In the first half of 2020, commissioning continues with a Ge-SSD and a double-objective X-ray microscope for energy-dispersive X-ray diffraction in the energy range of 30 – 200 keV with an unprecedented amount of photon flux. Efforts to eliminate characteristic Pb emissions (from shielding) and to reduce the background in the diffraction patterns from scattered X-rays are promising. Dedicated radiography (imaging) experiments in the LVP can be carried out using a 2 mm x 2 mm beam. A precise detector positioning system (built by Kohzu) will be delivered and installed in the period of April – May 2020. Following this, a second Ge-SSD will be added to the detection set up. The LVP is fully adapted for many different anvil/assembly set ups and can operate in 3 modes of compression, particularly to enhance the opportunity to conduct *in situ* rock deformation studies. During this dedicated satellite meeting for the LVP beamline P61B, beamline status, ongoing research and collaborative efforts will be presented. The meeting offers an opportunity for current and new users to meet with the beamline staff and with each other to discuss new research ideas for high pressure studies in the fields of Earth and Materials sciences and organic/inorganic Chemistry. P61B is joining the current call for proposals for beam time starting in II-2020.

Organisers: R. Farla, S. Bhat

Contact: robert.farla@desy.de

PROGRAMME

Session 1

			Chair: R. Farla
14:00 – 14:10	<i>Introduction</i>	R. Farla	DESY
14:10 – 14:35	<i>In situ X-ray observation study using a large-volume press at ultra-high-pressure and ultra-high-temperature conditions</i>	T. Katsura	BGI, Univ. of Bayreuth
14:35 – 15:00	<i>Materials landscapes development in alloys and nitrides using pressure, temperature, X-rays and precession electron diffraction</i>	G. Serghiou	Univ. of Edinburgh
15:00 – 15:25	<i>Crystal structure evaluation of novel binary and ternary high-pressure nitrides, synthesized in the LVP at P61B</i>	L. Wiehl	T. U. Darmstadt

15:30-16:00 Coffee break (30 Min.)

Session 2

			Chair: S. Bhat
16:00 – 16:25	<i>Chemical interaction in the B-X (X = S, Se, Te) systems at high pressure and high temperature</i>	V. Solozhenko	CNRS, Université Paris 13
16:25 – 16:40	<i>High-pressure synthesis of jadeite-based ceramic composites and their mechanical and optical performance</i>	E. Kulik	Univ. Kiel
16:40 – 16:55	<i>Supra-solidus phase relations of Ca-Mg-carbonates and melting point of hydrous magnesite in the upper mantle</i>	M. Sieber	GFZ, Potsdam
16:55 – 17:20	<i>Status and development of beamline P61B</i>	R. Farla	DESY
17:20 – 17:30	<i>Concluding remarks & questions</i>		
17:30 – 19:00	Beamline tour & discussions		

19:00

End of the workshop

SATELLITE WORKSHOP - Photon Science



SAXS/WAXS/GISAXS User Workshop @ DESY

30.01.2020

CSSB lecture hall, Bldg. 15

Following the big success of the SAXS/WAXS workshop in recent years, this workshop addresses current and potential users of small-angle X-ray scattering at PETRA III. It is intended to present and discuss the status and perspectives of the current and future experimental facilities in this field at DESY and recent as well as planned user activities. It shall foster communication among the users and identify common interests

Organisers: Rainer Gehrke, Stephan Roth

Contact: Stephan.roth@desy.de

PROGRAMME

13:00	Welcome & Overview of current and future SAXS capabilities at PETRA III Session 1: Biomaterials - Cellulose	Stephan V. Roth	DESY & KTH
13:10	P03 Nanofocus Endstation: news, updates, perspectives	Anton Davydok	HZG
13:25	Status of Biological SAXS at the EMBL P12 beamline	Andrey Gruzinov	EMBL
13:40	Well-defined polymers and surface modifications	Linda Fogelström	KTH
14:00	Formation of joints during drying of cellulose Session 2: Composite Materials	Torbjörn Pettersson	KTH
14:20	Advances at P03/MiNaXS	Matthias Schwartzkopf	DESY
14:35	Scattering from materials under deformation - state of the art and perspectives	Konrad Schneider/ Adam Kiersnowski	IPF & TUDD
14:55	Bone quality during skeletal development: structural and compositional adaptations on the micro- and nanoscale	Kilian Stockhausen	UKE
15:15	Nano Grain Mapping: High resolution 3D X-ray diffraction microscopy using nano focused X-rays	Hergen Stieglitz	HZG
15:35-16:10 Coffee break (35 Min.)			
	Session 3: Mapping in reciprocal space		Chair: Matthias Schwartzkopf
16:10	Small Angle X-ray Scattering Beamline for Materials Research (P62): Status and Outlook	Sylvio Haas	DESY
16:25	The high-resolution diffraction beamline P08 - status & highlights	Florian Bertram	DESY
16:40	Soft Matter Confined in Nanopores: 3-D Reciprocal Space Mapping and Single-Pore Diffraction Experiments	Patrick Huber	TUHH
17:00	Active layer printing of hybrid solar cells with in situ GISAXS and GIWAXS Session 4: Surface control	Volker Körstgens	TUM
17:20	Studying organic solar cells in operando with GISAXS and GIWAXS	Peter Müller-Buschbaum	TUM
17:40	Probing the drying and consolidation of a wet-spun nanocellulose fiber using scanning SAXS	L. Daniel Söderberg	KTH
18:00	Structure Induced Device Degradation in Quantum Dot Solar Cell	Wei Chen	TUM
18:20	End of the workshop		



High-energy X-rays for Swedish Materials Science (P21.2)

30 January 2020

SemR. O1.030, Bldg 48f

High-energy synchrotron x-rays provides a powerful probe for materials characterization across materials science disciplines. In order to meet the requirements from the Swedish materials community and to complement the lower energy synchrotron x-ray facility MAX IV, Sweden has invested in the Swedish Materials Science beamline (SMS) P21 at PETRA III. P21.2 is setup for experiments combining diffraction and small-angle scattering or imaging, in particular in-situ and in-operando studies are emphasized. After the commissioning phase basic functionalities are provided and the first user run has been completed. The beamline status and experiences at P21.2 will be reported. This workshop is intended to bring together the research community interested in the current and future capabilities of P21.2.

Organisers: P. Hedström, F. Eriksson, T. Zhou, U. Lienert Contact: ulrich.lienert@desy.de

PROGRAMME

Session 1: Beamline & experiments

13:00	Status of the SMS inline branch P21.2	Ulrich Lienert	DESY
13:30	User presentation	Ru Peng	LiU
13:50	User presentation	Magnus Colliander	CTH
14:10	User presentation	Jinshan Pan	KTH
14:30	User presentation	Emmanuel Larsson	RISE
14:50	Presentation thin-film deposition and cutting interaction	Fredrik Eriksson	LiU
15:10	User presentation	Johan Gustafson	LU

15:30- *Coffee break (30 Min.)*

16:00

Session 2: Community activities & discussion

16:00	Center for X-rays in Swedish Materials Science	Peter Hedström	KTH
16:20	Open session and Discussion about activities to stimulate Swedish community	N.N.	
17:00	P21 beamline tour		

18:30 *End of the workshop*

SATELLITE WORKSHOP - Photon Science



Satellite Meeting: X-ray absorption spectroscopy at P64/65

Thursday, 30 January 2019

SemR 4ab, Bldg. 1b

The two XAFS-beamlines P64 and P65 are in user-operation mode now for a few years. The satellite workshop is intended to give an overview about the current status of the beamlines, the associated projects, and results from different external user groups. Short- and long-term plans for instrumentation concerning experimental techniques and sample environments will be presented and discussed, as well as results from users' experiments. Present and future users are strongly encouraged to participate in this workshop and to discuss their options with the beamline staff.

Organisers: Edmund Welter, Wolfgang Caliebe

Contact: edmund.welter@desy.de,
wolfgang.caliebe@desy.de

PROGRAMME

Session 1: Instrumentation

Chair: Wolfgang Caliebe

14:00	Status of P65	Edmund Welter	DESY
14:20	Status of P64	Wolfgang Caliebe	DESY
14:40	High Resolution hard X-ray Spectroscopy at PETRA III Beamline P64: Present and Future	Aleksandr Kalinko	Univ. Paderborn
15:00	Status and future of time-resolved techniques at P64	Vadim Murzin	Univ. Wuppertal
15:20	tba	Michael Knapp	KIT

15:40 Coffee break

Session 2: Experimental Results

Chair: Edmund Welter

16:10	tba	Marion Louvel	Univ. Muenster
16:25	tba	Anselm Loges	Univ. Muenster
16:40	Defect Investigations by element-specific excitation of optical luminescence	Sergiu Levenco	Univ. Leipzig
17:00	tba	Rachit Khare	TUM
17:20	Hard X-Ray Spectroscopy of organometallic complexes @ P64 beamline	Michal Nowakowski	Univ. Paderborn
17:40	Studies of heterogeneous catalysts using QEXAFS-XRD combination at P64, and the high temperature setup at P65	Dmitry Doronkin	KIT

18:15 End of the workshop



Satellite Meeting: 10th Workshop on X-ray Nano-Imaging of Biological and Chemical Systems at PETRA III

Thursday, 30 January 2020

CFEL Bldg.99, CFEL I-III

The workshop gives attention to X-ray microscopy at various PETRA III beamlines with special emphasis on applications in biology and chemistry. Several scientific highlights are presented and recent methodological and instrumental developments at PETRA III beamlines and the DESY NanoLab are discussed. X-ray microscopy will greatly benefit from a future upgrade of PETRA into the ultra-low emittance source PETRA IV. Participants are encouraged to discuss future scientific opportunities.

Organisers: G. Falkenberg & C.G. Schroer

Contact: Gerald.Falkenberg@desy.de

PROGRAMME

Session 1: Nano-imaging and P10 workshop session			
13:00	Welcome & X-Ray Microscopy Today and at PETRA IV	Christian Schroer	Chair: G. Falkenberg DESY/UHH
13:20	News from the Nanolab	Thomas Keller	DESY
13:30	Sample cells for X-ray ptychography and nanotomography - towards operando chemical imaging of catalysts and functional materials	Thomas Sheppard	Karlsruhe Institute of Technology
14:00	Multi-scale tomography of heart tissue: from Cardiomyocyte to whole heart	Marius Reichardt	Goettingen University
14:30	Revealing the organization of axonal bundles from synchrotron tomography using streamline tractography	Hans Martin Kjer	Technical University of Denmark
15:00	3D anatomy and spatial chemistry in animal-microbe symbioses – Correlative phase-contrast x-ray tomography, metabolite imaging and fluorescence microscopy	B. Geier	MPI Marine Microbiology
15:30-16:00	Coffee break (30 Min.)		
Session 2: Nano-imaging workshop			
			Chair: C.G. Schroer
16:00	Nano-imaging experiments with Multilayer Laue optics	Sasa Bajt	DESY
16:20	Soft x-Ray Fluorescence Nanoscopy with the AnImaX endstation for biomedical and environmental applications	L. Lühl	TU-Berlin
16:40	X-ray fluorescence analysis of metal distributions in cryogenic biological samples	A. Rosenhahn	Ruhr-Univ. Bochum
17:00	Optical microscopy-driven imaging control software with online data visualization	S. Van Malderen	U Ghent
17:15	Self-Absorption Correction for XRF-Tomography at P06	D. Brückner	DESY/Uni HH
17:40	Coupled Ptycho-Tomography	M. Kahnt	Max IV
18:00	Missing wedge tomography with deep learning	Xiaogang Yang	DESY
18:20	Closing remarks	Christian Schroer	DESY
18:25	End of the workshop		

III Poster Session Topics

III.1 Internal/Facility Poster

1. PETRA III: Advanced Applications of Synchrotron Radiation
O. H. Seeck, H.-C. Wille and C. Schroer
2. PETRA III Beamline P61B: Science at Extreme Conditions Using the LVP
R. Farla, S. Bhat, S. Sonntag, A. Chanyshv, S. Ma, N. Nishiyama, N. Gaida, T. Ishii and T. Katsura
3. P64 at PETRA III
W.A. Caliebe, M. Görlitz, A. Kalinko, V. Murzin, M. Naumova and A. Tayal
4. PETRA IV – The Ultimate 3D X-ray Microscope
C.G. Schroer, S. Klumpp, R. Röhlberger, E. Weckert, R. Wanzenberg, I. Agapov, R. Brinkmann, W. Leemans and the PETRA IV project team
5. DESY NanoLab
H. Noei, T.F. Keller, V. Vonk, R. Röhlberger and A. Stierle
6. Sample characterization and laboratory support at the European XFEL
C. Deiter, H. Han, J. More, J. Makroczyová, J. Schulz, K. Dörner, K. Lorenzen, J. Adriano, M. Izquierdo, M. Kloos, M. Kitel, M. Vakili, R. Schubert and V. Bazhenov
7. P62: Small Angle X-ray Scattering Beamline for Materials Research - SAXSMAT -
S. Haas, X. Sun, A. Conceicao and S. Pfeffer
8. In Situ and Nano X-ray Diffraction beamline P23: status and prospects
D.V. Novikov, J. Raabe, A. Khadiev and K. Maksimova
9. The Hard X-ray Micro/Nano-Probe beamline P06: Extending the energy range to 35 keV
G. Falkenberg, F. Seiboth, K.V. Falch, S.V. Malderen, A. Schropp and J. Garrevoet
10. The High Resolution Diffraction Beamline P08
F. Bertram, R. Kirchhof, C. Shen, S. Volkov, A.B. Dey and G. Bussone
11. Scientific instrument FXE
M. Biednov, D. Khakhulin, F.A. Lima, K. Kubicek, P. Zalden, A. Rodriguez-Fernandez, Y. Jiang, A. Galler, C. Bressler, P. Frankengerger, M. Knoll, T. Korsch, F. Otte, K. Boemer, T.K. Choi, M. Diez and W. Gawelda
12. The SCS instrument: the soft X-ray beamline for spectroscopy and diffraction and coherent scattering
G. Mercurio, C. Broers, R. Carley, J.T. Delitz, N. Gerasimova, R. Gort, L. Le Guyader, L. Mercadier, A. Sorin, J. Schlappa, M. Teichmann, B. van Kuiken, A. Yaroslavtsev and A. Scherz
13. Swedish Materials Science Beamline (SMS) at PETRA III: In-line branch (P21.2)
U. Lienert, S. Gutschmidt, T. Bäcker, Z. Hegedüs and T. Müller
14. Coherence Beamline P10
F. Westermeier, V. Kartik, Z. Ren, R. Rysov, D. Weschke and M. Sprung
15. Lab-Arena: The Development of Online Equipment Database of European and Worldwide Research Facilities
B.O. Postolnyi
16. The Centre for Molecular Water Science (CMWS)
C. Goy, F. Lehmkuhler, M. Schnell and G. Grübel
17. Resonant Scattering and Diffraction beamline P09 at PETRA III: Recent developments
S. Francoual, J.R.L. Mardegan, J. Sears, P. Bereciartua and J. Bergtholdt



**- TWINNUT -
the separable srew nut**

- put innovations into practice
- new construction possibilities
- simplified assembly & disassembly
- improved work savety due to reduceded working time in unhealthy environment
- assembly also on defective or difficult to access threads
- full strength and similar size as comparable standard nuts
- almost every size, shape and material available

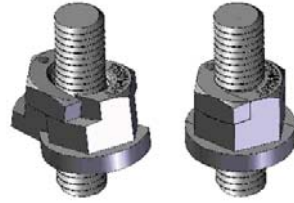

*TWINNUT ajar and locked
halboffen und geschlossen*

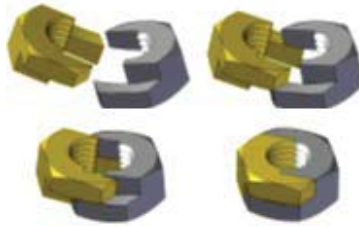

*Assembly of the TWINNUT halves
Zusammensetzen der TWINNUT*

TWINNUT GmbH
Jan-Körper-Weg 24
30826 Garbsen, Germany
Tel: +49 (0)5131 7022746
Fax: +49 (0)5131 7022749

**- TWINNUT -
die teilbare Schraubenmutter**

- Innovationen verwirklichen
- Neue Konstruktionsmöhlichkeiten
- Vereinfachte Mon.- & Demonatge
- verbesserter Arbeitsschutz durch verkürzte Arbeitszeit in schädlicher Arbeitsumgebung
- Montage auch an defekten und unzugänglichen Gewinden
- volle Zugfestigkeit bei gleicher Größe wie Standardmuttern
- Nahezu jede Gewindegröße, Bauform und Material verfügbar

DECTRIS
detecting the future

Meet the newest members
of the EIGER2 family



Visit our booth
#K27

18. Beamline P66 status report
A. Kotlov and I. Schostak
19. The surface and beyond: Operando spectroscopy at beamline P22
C. Schlueter, Yu. Matveyev, P. Lömker, A. Gloskovskii, K. Ederer, I. Schostak and W. Drube
20. Status of the Extreme Conditions Beamline (P02.2 and ECB)
H.P. Liermann, K. Glazyrin, A. Pakhomova, N. Giordano, M. Wendt and S. Wenz

III.2 Instrumentation and techniques

21. Status and future plans for the Diamond Anvil Setup (DAC) in IC2 at the HED instrument of the EuXFEL
H. P. Liermann on behalf of the HIBEF User Consortium and DAC user collaboration at HED of the EuXFEL
22. A modular load frame system for applying compressive or tensile stress to materials
T. Dose, J. Brehling, H. Burmester, B. Eltzhig, J. Moosmann, E. Euchler and R. Bernhardt
23. Operation of Photon Diagnostic Imagers at the European XFEL
A. Koch, J. Risch, W. Freund, M. Planas and J. Grünert
24. Correcting wavefronts of multilayer Laue lenses
K.T. Murray, A.J. Morgan, M. Prasciolu, H.N. Chapman and S. Bajt
25. Status and Outlook of the SAXS-CT sample environment at the SAXS beamline for materials research
A. Conceição and S. Haas
26. X-ray standing waves method at the P24 beamline
M. Kamiński and M. Tolkiehn
27. Compact Microfluidic Reactor for in situ Studies of Synthesis Stages
P. Medvedev
28. Post-compression of picosecond pulses to four optical cycles
P. Balla, A. Bin Wahid, I. Sytceвич, C. Guo, A. Schönberg, A.-L. Viotti, L. Silletti, A. Cartella, S. Alisauskas, H. Tavakol, U. Grosse-Wortmann, M. Seidel, B. Manschwetus, T. Lang, F. Calegari, A. Couairon, A. L`Huillier, Cord L. Arnold, I. Hartl and C.M. Heyl
29. Study of fast and ultra-fast time response of liquid-vapour interface by optical pump - X-ray probe technique
R. P. Giri, J. Warias, A. Sartori, B. Murphy and O. Magnussen
30. Challenges and Lessons Learnt for Nanosecond Timing @ MID
M. Osterhoff, M. Vassholz, H. Hoppe, J. Rossello, R. Mettin, J. Hagemann, A. Schropp, C. Schroer and T. Salditt
31. Updates from the GINIX instrument @ P10
M. Osterhoff, T. Salditt and M. Sprung
32. Automation of experiments at the SPB/SFX instrument of the European XFEL
A. Round, R.J. Bean, J. Bielecki, K. Doerner, Y. Kim, H.J. Kirkwood, A. Legrand, R. Letrun, B. Manning, L. Lopez Morillo, G. Mills, N. Reimers, T. Sato, J. Schulz, C. Signe Takem, M. Sikorski, S. Stern, P. Thute, P. Vagovic and A.P. Mancuso
33. Femtosecond 100 W-level OPCPAs from 800 nm to 2 μm
R. Riedel, M. Schulz, I. Grguras, T. Golz, J.H. Buß and M.J. Prandolini
34. New AGIPD Detectors and Developments for the European XFEL
J. Becker, A. Delfs, R. Dinapoli, S. Fridman, P. Göttlicher, H. Graafsma, D. Greiffenberg, H. Hirsemann, S. Jack, A. Klyuev, H. Krueger, M. Kuhn, S. Lange, T. Laurus, A. Marras, D. Mezza, A. Mozzanica, J. Poehlsen, S. Rah, B. Schmitt, J. Schwandt, O. Shefer-Shalev, I. Sheviakov, X. Shi, S. Stern, U. Trunk and M. Zimmer

35. Smart*Light – An Inverse Compton Source for Cultural Heritage
M. Alfeld, H.L. Casticum, P.H.A. Mutsaers, J. Dik, K. Janssens and O.J. Luiten
36. X-ray measurements of bovine red blood cells in continuous flow
J. Burchert, G. Brehm, R. Graceffa, M. Burghammer and S. Köster
37. An XUV and soft X-ray split-and-delay unit for FLASH2
M. Dreimann, S. Roling, I. Zadyraka, M. Kuhlmann, E. Plönjes-Palm, F. Wahlert, F. Rosenthal, M. Wöstmann and H. Zacharias
38. Desk-top near edge soft X-ray absorption fine structure spectroscopy based on a laser plasma double stream gas puff target source
P.W. Wachulak, M. Duda, A. Bartnik, A. Sarzyński, L. Wegrzynski, M. Nowak, H. Fiedorowicz, A. Jančárek and L. Pína
39. Classification of diffraction patterns in Single Particle Imaging experiments performed at XFELs using a Convolutional Neural Network (CNN)
A. Ignatenko, D. Assalauova, S.A. Bobkov, L. Gelisio, A.B. Teslyuk, V. A Ilyin, SPI consortium @ LCLS, A. Aquila and I.A. Vartanians
40. Hanbury Brown and Twiss interferometry at SCS Instrument at European XFEL
R. Khubbutdinov, N. Gerasimova, G. Mercurio, D. Assalauova, L. Gelisio, J. Carnis, O. Gorobtsov, A. Ignatenko, Y.Y. Kim, R. Kurta, D. Lapkin, N. Mukharamova, M. Scholz, A. Scherz, A.P. Menushenkov and I.A. Vartanians
41. FemtoMAX
A. Jurgilaitis, V. Pham, S. Checchia, H. Coudert-Alteirac, D. Kroon and J. Larsson
42. Nanostructured diffractive X-ray optics from the Paul Scherrer Institut
F. Döring, A. Kubec and C. David
43. A direct temperature measurement of resistively heated diamond using inelastic X-ray scattering
A. Descamps, B. Ofori-Okai, L. Fletcher, J.B. Hastings, O. Karnbach, D. McGonegle, C. Palmer, O. Humphries, J. Wark, G. Gianluca, U. Zastra, K. Appel, L. Wollenweber, T. Preston, C. Strohm, C. Plueckthun, A. Comley, A. Jenei, J. Eggert, R. Loetzsch, I. Uschmann, D. Senesky, S.H. Glenzer and E.E. McBride
44. Harmonic lasing self-seeding at FLASH and the European XFEL
E. Schneidmiller, F. Brinker, W. Decking, B. Faatz, M. Guetg, M. Kuhlmann, S. Liu, D. Noelle, J. Roensch-Schulenburg, M. Scholz, S. Schreiber, M. Tischer, M. Yurkov, I. Zagorodnov, N. Gerasimova, G. Geloni, J. Gruenert, J. Laksman, Y. Li, J. Liu, S. Karabekyan, N. Kujala, Th. Maltezopoulos, I. Petrov, L. Samoylova, S. Serkez, H. Sinn and F. Wolff-Fabris
45. Simulating wavefront propagation for a beamline with split-and-delay unit and compound refractive lenses at the European X-ray Free Electron Laser
V. Kärcher, S. Roling, L. Samoylova, A. Buzmakov, U. Zastra, K. Appel, M.V. Yurkov, E. Schneidmiller, F. Siewert and H. Zacharias
46. Single-shot pulse-energy correlations between multiple devices at European XFEL
Th. Maltezopoulos, O. Brovko, F. Dietrich, W. Freund, A. Grebentsov, U.F. Jastrow, A. Koch, J. Laksman, J. Liu, M. Planas, A. Sorokin, K. Tiedtke and J. Gruenert
47. Adaptive X-ray optics for time-resolved studies
V. Akkuratov, I. Eliovich, A. Targonskii, Yu. Pisarevsky and A. Blagov
48. A Machine Learning Approach to XFEL Data Analysis
P. Vester
49. Recent developments towards high-flux time-resolved & THz-SAXS experiments at the EMBL P12 BioSAXS beamline
M.A. Schroer, S. Schewa, C.E. Blanchet, A. Y. Gruzinov, I. Josts, S. Fiedler, H. Tidow, G. Katona, M. Roessle and D.I. Svergun

50. Commissioning and first experimental observations of bent diamond spectrometer at MID instrument of European XFEL
I. Petrov, U. Boesenberg, J. Hallman, K. Kazarian, C. Kim, W. Lu, A. Madsen, J. Moeller, M. Reiser, L. Samoylova, M. Scholz, R. Shayduk and A. Zozulya
51. First observations of heat load effects on cryo-cooled monochromator at European XFEL
I. Petrov, U. Boesenberg, M. Dommach, J. Eidam, J. Hallman, K. Kazarian, C. Kim, W. Lu, A. Madsen, J. Moeller, M. Reiser, L. Samoylova, M. Scholz, R. Shayduk, H. Sinn, V. Sleziona, A. Zozulya, X. Dong, J. Anton, S. Kearney and D. Shu
52. URSA-PQ@FLASH: A mobile and highly flexible endstation for pump-probe electron spectroscopy at FLASH2
J. Metje, D. Mayer, F. Lever, M. Niebuhr, M. Robinson, A. Heuer, R. Squibb, R. Feifel, S. Düsterer and M. Gühr
53. Laser-induced transient thermal gratings for pulse picker applications
D. Schmidt, R. Bauer and P. Gaal
54. Deep Learning: New Approaches for the Investigation of Protein Dynamics via XPCS
S. Timmermann, H. Rahmann, A. Girelli, N. Begam, A. Ragulskaya, M. Reiser, C. Lovato, F. Westermeyer, M. Sprung, F. Zhang, F. Schreiber and C. Gutt
55. Thermal diffuse scattering X-ray measurements on a metal-organic framework compound and on thiourea with high energy photons
J. Büscher, M. Stękiel, D. Spahr, W. Morgenroth, E. Haussühl, O. Ivashko, M. von Zimmermann, A.-C. Dippel and B. Winkler
56. A hard X-ray Split-and-delay Unit for the High Energy Density Instrument at the European XFEL
S. Roling, V. Kärcher, D. Eckermann, K. Appel, S. Braun, P. Gawlitza, F. Siewert, U. Zastra, M. Dreimann, F. Wahlert and H. Zacharias
57. Liquid Sample Delivery Solutions at the European XFEL
M. Vakili, L. Adriano, K. Dörner, H. Han, M. Kloos, J. Knoska, A. Mancuso, J. Makroczyova, M. Sawatzki, R. Schubert and J. Schulz
58. X-ray multibeam ptychography
F. Wittwer, M. Lyubomirskiy, F. Koch, M. Kahnt, M. Seyrich, J. Garrevoet, C. David and C. Schroer
59. Beamlines at PoFEL facility
K. Szamota-Leandersson, R. Nietubyć, J. Sekutowicz, P. Czuma, P. Krawczyk, J. Lorkiewicz, N. Palka, P. Zagrajek, P. Wachulak, K. Janulewicz, H. Fiedorowicz, J. Krzywinski, M. Terka, M. Staszczak and J. Szewiński
60. Mobile instrumentation set-up for X-ray diffraction imaging applied at PETRA III
S. Haaga, M. Kabukcuoglu, S. Bode, D. Hänschke, E. Hamann, M. Zuber, T. Baumbach and A. Danilewsky
61. Intensity Correlations in Radiographic Images
C. Niehaves and T. Salditt
62. EUV Wavefront sensing at near field for characterizing a Schwarzschild objective
M. R. Lopez, M. Mehrjoo, B. Keitel, E. Plönjes, U. Zastra, D. Alj, L. Lu, G. Dovillaire and P. Zeitoun
63. Compact hard X-ray split-and-delay line for studying ultrafast dynamics at free-electron laser sources
R. Rysov, W. Roseker, M. Walther, H. Schulte-Schrepping and G. Grübel
64. Opportunities for resonant elastic and inelastic X-ray scattering studies at the SCS instrument of European XFEL
J. Schlappa

65. Time-resolved high resolution resonant inelastic soft X-ray scattering end station at the FLASH PG1 beamline
S. Dziarzhytski, P. Miedema, H. Weigelt, H. Redlin, M. Ruebhausen, M. Beye and G. Brenner
66. First Characterization of the Photon Beam at the European XFEL in July and 2017
V. Balandin, B. Beutner, F. Brinker, W. Decking, M. Dohlus, L. Froehlich, U. Jastrow, R. Kammering, T. Limberg, D. Noelle, M. Scholz, A. Sorokin, K. Tiedtke, M. Yurkov, I. Zagorodnov, J. Liu, L. Samoylova, U. Boesenberg, W. Freund, J. Grünert, A. Koch, N.G. Kujala, T. Maltezopoulos, M. Messerschmidt, I. Petrov and H. Sinn
67. Experience With MCP-Based Photon Detector at FLASH2
S. Grunewald, E. Muller, E. Schneidmiller, K. Tiedtke, M. Yurkov, O. Brovko, A. Grebentsov and E. Syresin
68. Femtosecond Temporal Multiple Diffraction in Single Crystals
A. Rodriguez-Fernandez
69. High-pressure resonant X-ray diffraction setup at Beamline P09 and PETRA III
J. Sears, P.J. Bereciartua, M. Kusch, G.S. Thakur, K. Glazyrin, J. Geck, M. Jansen and S. Francoual
70. High-speed pixel detector development
D. Pennicard, J. Correa, U. Trunk, S. Lange, A. Klyuev, A. Marras, S. Smoljanin, S. Fridman and H. Graafsma
71. Commissioning the two-branch soft X-ray beamline P04 at PETRA III
M. Hoesch, K. Bagschik, J. Seltmann, F. Trinter, M.-J. Huang, F. Scholz and J. Viefhaus
72. Flexible regime ptychography at FLASH
K. Kharitonov, M. Mehrjoo, B. Keitel and E. Plönjes
73. XUV-PUMA - An Advanced Timing Tool
L. Jepsen, V. Tkachenko, M. Büscher, A. Malik, S. Toleikis, B. Ziaja-Motyka and U. Teubner
74. Single-shot temporal characterization of XUV SASE FEL pulses
R. Ivanov, I. Bermudez, J. Liu, G. Brenner and S. Düsterer
75. How to: 10nm Ptychography
M. Seyrich, L. Grote, F. Wittwer, M. Kahnt, D. Brueckner, R. Doehrmann, S. Botta, P. Wiljes, J. Garrevoet, D. Koziej and C. Schroer
76. C³AdMat project at BESSY II: standardized characterization and validation of advanced materials
A. Smekhova, E. List-Kratochvil and A. Vollmer
77. Radial dynamic diamond anvil cell experiments at P02.2
L. Huston, L. Miyagi, R. Husband, H.-P. Liermann and B. Sturtevant
78. Accuracy and velocity dependency of magnetic measurements taken in the XFEL laboratories
U. Englisch, P. Li and J. Pflueger
79. Shock heating and Melting of Fe with an X-ray laser
S. White, B. Kettle, C.L.S. Lewis, C.D. Murphy, J. Vorberger, S.H. Glenzer, D.O. Gericke, B. Nagler, H.J. Lee, F. Tavella and D. Riley
80. Possibilities for Magnetic and Cryogenic Sample Environments at MID Instrument
J.D. Moore, C. Deiter, J. Schulz, A. Madsen and K. Kazarian
81. The Fast Solid Sample Scanner - One Year of Operation and Further Developments
C. Deiter, M. Kitel, J. Tolkiel, E. Delmas and J. Schulz
82. Endstation for time-resolved X-ray photoemission spectroscopy at FELs
L. Wenthous, S. Palutke, D. Kutnyakhov, H.D. Meyer and S. Gieschen

NEW

Flexible Nanopositioning Solutions for Large Scale Facilities



ECSxXL – long travel range with nanometer accuracy

- travel range up to 125 mm
- repeatability 50 nm
- vacuum compatible
- basis for multi-axis systems
- optional optoelectronic encoder

DESY Photon Science
Users' Meeting 30 – 31
January, 2020 meet
attocube at booth #38

www.attocube.com

MOTION & SENSING
precision engineering components

Your Partner for X-ray Optics, X-ray Tubes & Microfocus Sources



Incoatec Microfocus Sources IμS^{High Brilliance} - IμS 3.0 / DIAMOND



IμS Duo upgrade



The incoatec enclosure IXE



iXmini - portable X-ray source for detector calibration



PHOTON III - Affordable CPAD technology

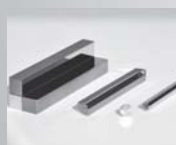

Synchrotron Montel Optics



Double crystal multi-layer monochromators with two stripes



Double crystal multi-layer monochromators with three stripes



SCATEX - Ge or Ta scatterless pinholes

Incoatec develops, produces and supplies components for X-ray analytical systems. These components include optics, mirrors, tubes and microfocus sources for applications in X-ray diffraction, X-ray scattering, and X-ray spectrometry. We offer solutions for chemical and pharmaceutical research, semiconductor industry, heavy industry, life science and nanotechnology, enabling our customers to make better use of their resources and improve their results. Using our extensive know-how in thin film technology together with our in-house mechanical and electronic departments, we are able to provide reliable, efficient and eco-friendly products: Made in Germany.

Our customer support and service will accompany you through the various steps from selecting the most suitable solution, having your system up and running, up to assisting you even after your system has been installed. All in one - at your service.

Solutions made by incoatec!

Contact and challenge us!

www.incoatec.de

sales@incoatec.de

83. Advanced Multilayer Deposition on 20 mm and 200 mm
M. R. Moayed, A. Siemens, C. Adolff, J. Lütjens, S. Willing, L. Bocklage, K. Schlage and R. Röhlberger
84. Status of dataflow processing pipeline for SPI experiments at European XFEL
S. Bobkov, A. Teslyuk, S. Zolotarev, K. Ikonnikova, V. Velikhov, I. Vartanyants and V. Ilyin
85. Modification of EMC algorithm for improved orientation recovery in SPI experiments
S. Zolotarev
86. CAMP@FLASH
C. Passow, C. Papadopoulou, A. Tul Noor and B. Erk
87. Separating spin and orbital magnetic dynamics via X-ray absorption lines
N. Thielemann-Kühn, T. Amrhein, W. Bronsch, S. Jana, N. Pontius, R. Y. Engel, P. Miedema, B. Beye, B. E. van Kuiken, M. Teichmann, R.E. Carley, L. Mercadier, A. Yaroslavtsev, G. Mercurio, L. Le Guyader, N. Agarwal, A. Scherz, P.M. Oppeneer, M. Weinelt and C. Schüssler-Langeheine
88. A Portable Endstation for Analytical X-ray Microscopy
A. Haidl, L. Lühl, A. Dehlinger, J. Heym, K. Andrianov, T. Nisius, B. Kanngießler and T. Wilhein
89. New Opportunities for Time-Resolved Photoelectron Spectroscopy at the European XFEL
S. Thiess, J. Buck, K. Rossnagel, W. Wurth, M. Izquierdo, S. Molodtsov and TR-XPES User Consortium
90. Nanosecond X-ray Photon Correlation Spectroscopy using pulse time structure of storage ring source
W. Jo, F. Westermeier, R. Rysov, O. Leupold, F. Schulz, S. Tober, V. Markmann, M. Sprung, A. Ricci, T. Laurus, A. Aschkan, A. Marras, U. Trunk, H. Graafsma, G. Grübel and W. Roseker
91. Lock-in amplification for X-ray beam induced current measurements
C. Ossig, T. Nietzold, B. West, M. Bertoni, G. Falkenberg, C. Schroer and M. Stuckelberger
92. X-ray parametric down-conversion - theory and prospects
D. Krebs and N. Rohringer
93. Deep Learning for quantitative Coherent Diffraction Imaging
A. Colombo, J. Zimmermann and D. Rupp
94. Design of an APPLE III Undulator with magnetic force compensation for FLASH 2020+
P. Vagin, D. Meissner, A. Schöps and M. Tischer
95. Experimental Study of Oblique X-ray Incidence in a Pixelated Semiconductor Detector: First Results
T. Rüter, S. Hauf, R. Hartmann, H. Youself, M. Kuster and L. Strüder
96. Commissioning of High REsolution hard X-ray single-shot Spectrometer (HIREX spectrometer) of SASE2 beamline
N. Kujala, W. Freund, A. Koch, J. Liu, M. Planas and J. Grünert
97. Artificial channel-cut monochromators of the MID instrument at European XFEL
A. Zozulya, U. Boesenberg, X. Dong, J. Hallmann, K. Kazarian, C. Kim, W. Lu, J. Moeller, I. Petrov, M. Reiser, T. Roth, L. Samoylova, M. Scholz, R. Shayduk, S. Shu, V. Sleziona, H. Sinn and A. Madsen
98. Recent developments at μ CT endstation of the P05 beamline
F. Wilde, J.U. Hammel, J. Moosmann, F. Beckmann, I. Greving, M. Störmer, T. Dose, H. Burmester, J. Brehling, L. Lottermoser and C. Krywka
99. XFEL pulse energy monitoring - absolute calibration and MHz rates
J. Grünert, W. Freund, J. Liu and T. Maltezopoulos
100. Neutron Reflectivity Data fitting via Artificial Neural Networks
A. Greco, V. Starostin, C. Karapanagiotis, A. Hinderhofer, A. Gerlach, L. Pithan, S. Liehr, F. Schreiber and S. Kowarik

101. Optical laser capabilities and applications at SPB/SFX
R. Letrun, T. Sato, J. Koliyadu, H. Kirkwood, J. Liu, G. Palmer, M. Emons, P. Thute, N. Reimers, L. Lopez, C. Takem and A. P. Mancuso
102. Fast Fitting of Reflectivity Data of Growing Thin Films Using Neural Networks
A. Greco, V. Starostin, C. Karapanagiotis, A. Hinderhofer, A. Gerlach, L. Pithan, S. Liehr, F. Schreiber and S. Kowarik
103. Preparation of a proof-of-principle experiment on SASE THz FEL at PITZ
M. Krasilnikov
104. Variable period undulator
P. Vagin, H. Bolat, A. Schöps and M. Tischer
105. Three-Dimensional Mapping of Diffuse Scattering in Single Crystals
O. Ivashko, O. Gutowski, A. Sarma, S. Banerjee, A.-C. Dippel and M. von Zimmermann
106. Development of a high quality X-ray Scattering and X-ray Raman Spectroscopy setup for the characterization of warm dense carbon at the HED instrument of EuXFEL
K. Voigt, D. Kraus, N.J. Hartley, A.K. Schuster, M. Zhang, L. Huang, D. Chekrygina, K. Falk, M. Smid, M. Harmand, A. Amouretti, S. Hau-Riege, L.B. Fletcher, R. Falcone, K. Appel, T. Preston, A. Pelka, C. Prescher, V. Cerantola, S. Göde, T. Toncian, E. Brambrink, U. Zastra and M. Makita
107. Distortion Correction for large area XRD detectors
C. Prescher, P. Talkovski, K. Glazyrin, C. Strohm and H.-P. Liermann
108. Dynamic heating and compression experiments with the novel resistive heated diamond anvil cell at the Extreme Conditions Beamline P02.2 and PETRA III
C. Otzen, F. Langenhorst and H.-P. Liermann
109. Optical laser delivery to the SCS instrument - First measurements of time arrival jitter
L. Mercadier, N. Agarwal, C. Broers, R. Carley, J.-T. Delitz, N. Gerasimova, R. Gort, L. Le Guyader, G. Mercurio, A. Reich, J. Schlappa, M. Teichmann, B. Van Kuiken and A. Yaroslavtsev
110. Development of the extreme conditions sample environment for X-ray emission spectroscopy and nuclear-resonant spectroscopies at P01
G. Spiekermann, I. Kuppenko, S. Petitgirard, C. Sahle, M. Harder, I. Sergueev, C. Sternemann and M. Wilke
111. Comparison of two low-noise CEP stabilization methods for an environmentally stable Yb: fiber oscillator
S. Salman, Y. Ma, K. Guerel, S. Schilt, C. Li, P. Pfaefflein, C. Mahnke, J. Fellingner, S. Droste, A. Mayer, O. Heckl, T. Suedmeyer, C. Heyl and I. Hartl
112. HHG based pump-probe source at FLASH2
E. Appi, C. Papadopoulou, S. Alisauskas, T. Lang, C. Heyl, B. Manschwetus, I. Hartl, U. Morgner and M. Kovacev
113. High speed 3D particle tracking from stereo-view imaging
K. Vidar Falch, M. Drakopoulos, P. English, F. Wu, D. Guo and W. Mirihanage
114. High-energy diffuse and total X-ray scattering techniques at P07-EH2 and P21.1
S. Banerjee, A.-C. Dippel, P. Glaeveccke, O. Gutowski, O. Ivashko, R. Nowak, A. Sarma, Marina Sturm and M. v. Zimmermann
115. A Phase Retrieval Toolbox for X-ray Holography and Tomography
L.M. Lohse, A.-L. Robisch, M. Töpperwien, S. Maretzke, M. Krenkel, J. Hagemann and T. Salditt
116. A beamline combining XUV attosecond pulses with sub 2-fs deep UV pulses
L. Colaizzi, V. Wanie, M. Galli, D. Pereira Lopes, E.P. Månsson, A. Trabattoni, K. Saraswathula, A. Cartella, F. Frassetto, L. Poletto, F. Légaré, S. Stagira, M. Nisoli, R. Martinez Vazquez, R. Osellame and F. Calegari

LIQUID COOLING IN VACUUM



DESIGN OF COMPONENTS

Feasibility studies and tests

PRECISION MACHINING

3D CAD/CAM programming and manufacturing

JOINING TECHNOLOGY

High vacuum brazing and laser welding

ULTRA HIGH VACUUM TECHNOLOGY

Cleanroom engineering

PROJECT MANAGEMENT

Sourcing and purchasing

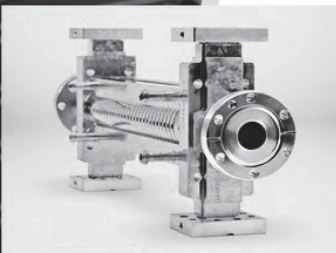
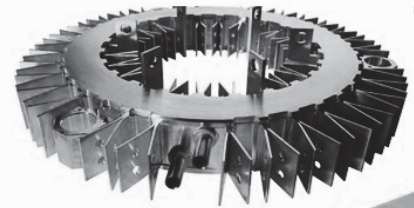
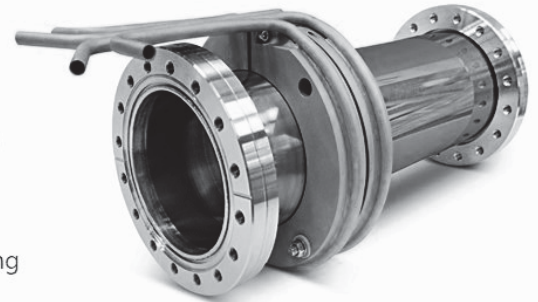

REUTER TECHNOLOGIE GmbH · Röntgenstraße 1 · D-63755 Alzenau · Germany · www.precision-brazing.com
Tel. +49 (0)6023/5044-0 · Fax +49 (0)6023/5044-29 · Mail: contact@reuter-technologie.de

Your Premier Source for High Power & Peak Intensity Laser Components

- › Optics for High Power Laser Applications
- › Ion Beam Sputtered Advanced Coatings
- › Nonlinear and Laser Crystals
- › Pockels Cells and Drivers
- › Laser Electronics



 **EKSMA**
OPTICS

WWW.EKSMAOPTICS.COM

117. Megahertz Beam Characterization by Multishot Desorption Imprints in PMMA
V. Vozda, B. Keitel, B. Faatz, D. Klöngler, E. Plönjes, E. Louis, F. Scholze, F. Siewert, G. de Vries, H. Enkisch, I. A. Makhotkin, I. Jacyna, K. Tiedtke, K. Saksli, L. Juha, M. Jurek, M. Hermann, R. Loch, R. Sobierajski, S. Strobel, S. Toleikis, T. Burian, V. Hájková, Z. Zelinger and J. Chalupský
118. Beam-splitting off-axis zone plate setup for time-resolved X-ray absorption spectroscopy at the SCS instrument
L. Le Guyader, F. Döring, B. Rösner, A. Eschenlohr, M. Beye, N. Agarwal, C. Broers, R. Carley, J.T. Delitz, N. Gerasimova, R. Gort, L. Mercadier, G. Mercurio, A. Reich, J. Schlappa, M. Teichmann, B. Van Kuiken, A. Yaroslavtsev, Ch. David and A. Scherz
119. Attosecond soft X-ray beamline for dispersive absorption spectroscopy of solid-state systems
D. Rivas, N. Di Palo, T. Sidiropoulos, S. Severino, M. Reduzzi, T. Danz, M. Valdivares, P. Gargiani, E. Pellegrin and J. Biegert
120. Hard X-ray photoemission microspectroscopy
C. Wiemann, M. Wilhelm, C. Schlüter, A. Gloskovskii and C.M. Schneider
121. 3 in 1: Combined time-resolved photoelectron spectroscopies in time-of-flight momentum microscope setup at free electron laser
D. Kutnyakhov, R.P. Xian, M. Dendzik, M. Heber, F. Pressacco, S.Y. Agustsson, L. Wenthaus, H. Meyer, S. Gieschen, K. Bühlman, S. Däster, R. Gort, D. Curcio, K. Volckaert, M. Bianchi, Ch. Sanders, J.A. Miwa, S. Ulstrup, A. Oelsner, C. Tusche, Y.-J. Chen, D. Vasilyev, K. Medjanik, G. Brenner, S. Dziarzhyski, S. Dong, J. Hauer, L. Rettig, J. Demsar, K. Rossnagel, H.-J. Elmers, Ph. Hofmann, R. Ernstorfer, G. Schönhense, Y. Acremann and W. Wurth
122. Photon Arrival time Monitor (PAM): a MHz timing tool at the European XFEL
J. Liu, H. J. Kirkwood, R. Letrun, A. P. Mancuso, T. Sato and J. Grünert
123. Spectral μ CT with an Energy Resolving and Interpolating Pixel Detector
L. M. Lohse, M. Vassholz, M. Töpperwien, T. Jentschke, A. Bergamaschi, S. Chirioti and T. Salditt
124. Femtosecond X-ray absorption spectroscopy at the SCS instrument of European XFEL
A. Yaroslavtsev, A. Reich, M. Izquierdo, L. Le Guyader, N. Gerasimova, L. Mercadier, G. Mercurio, N. Agarwal, R. Carley, M. Teichmann, D. Hickin, J.T. Delitz, C. Broers, J. Schlappa, J. Zhu, Th. Maltezopoulos, F. Dietrich, J. Grünert and A. Scherz
125. Multimodal X-ray microscopy of biological specimens
K. Stachnik, I. Mohacsi, M. Warmer, V. Hennicke, P. Fischer, J. Meyer, T. Spitzbart, M. Barthelmess, J. Eich, M. Prasciolu, C. David, C. Feldmann, S. Bajt, B. Busse, K. Jaehn, U.E. Schaible and A. Meents
126. Developments in time-resolved XAFS Spectroscopy at P64
B. Bornmann, F. Eckelt, P. Pagel, P. Rothweiler, L. Voss, V. Murzin, D. Lützenkirchen-Hecht and R. Frahm
127. Nitrogen K-edge X-ray Absorption Spectroscopy at FLASH near the Shot-Noise Limit
R.Y. Engel, M. Ekimova, P.S. Miedema, C. Kleine, J. Ludwig, M. Ochmann, B. Grimm-Lebsanft, R. Ma, M. Teubner, S. Dziarzhyski, G. Brenner, M.K. Czwalianna, B. Rösner, T.K. Kim, C. David, S. Herres-Pawlis, M. Rübhausen, E.T.J. Nibbering, N. Huse and M. Beye
128. Towards in-situ Nanotomography at the Imaging Beamline P05
E. Longo, S. Flenner, A. Kubec, F. Wilde, H. Burmester, U. Tietze, J. Brehling, L. Lottermoser, T. Dose, F. Beckmann, C. David and I. Greving
129. Tomographic alignment for joint ptychotomography using differential phase contrast data
A. Slyamov, V. Nikitin, D. Gursoy, R. Mokso and J. Andreassen
130. Plug-in MLL optics with long working distances for X-ray Nanodiffraction
P. Gawlitza, A. Kubec, S. Niese and J. Keckes

131. High energy resolution hard X-ray spectroscopies in the laboratory
Z. Németh, É.G. Bajnóczy, C. Bogdán and G. Vankó
132. PtyNAMi - High-Resolution X-ray Microscopy at Beamline P06
A. Schropp, S. Botta, R. Döhrmann, J. Garrevoet, M. Kahnt, M. Lyubomirskiy, M. Seyrich, P. Wiljes, F. Wittwer and C.G. Schroer
133. Development of a novel synchrotron Mössbauer source at PETRA III
S. Sadashivaiah, I. Sergueev, O. Leupold, T. Hochdörffer, C.S. Müller, A. Omlor, H.-C. Wille, R. Röhlberger, R. Ruffer, J.A. Wolny and V. Schünemann
134. Laboratory based time- and momentum-resolved photoemission experiments using time-of-flight momentum microscopy with HHG of a Ti:Sa laser
N. Wind, M. Martins, D. Kutnyakhov, F. Pressacco and M. Heber
135. FLASH2 pump-probe laser: current status and performance
N. Schirmel
136. Measuring bremsstrahlung bursts in ultra-intense laser-plasma experiments: a compact multi-scintillator detector working at high repetition rate
M. Molodtsova, A. Laso Garcia, J. Metzkes-Ng, S. D. Kraft, B. Lutz, M. Sobiella, D. Stach, D. Weinberger, T. Ziegler, T.E. Cowan and A. Ferrari
137. Passively Compensating for Thermal Expansion: A Height-Stable Temperature Stage for Grazing Incidence X-ray Scattering
M. Buchhorn and E. Herzig
138. High-resolution 3D printed nozzles towards nanometer-thin sheets jets and ultra-fast liquid jets
G.E. Pena Murillo, J. Knoska, F. Cruz Mazo, S. Awel, K. Zielinski, D. Oberthuer, M. Wiedorn, S. Bajt, A.M. Ganan-Calvo and H. Chapman
139. Compact 3D printed mixers and nozzles for structural biology
J. Knoska, L. Adriano, S. Awel, K.R. Beyerlein, O. Yefanov, D. Oberthuer, G.E. Peña Murillo, I. Sarrou, P. Villanueva-Perez, F. Wilde, M. Heymann, S. Bajt and H.N. Chapman

III.3 Atoms, molecules, clusters, ions and plasmas

140. New resonances in multiple inner-shell photodetachment of C⁻ ions
A. Perry-Sassmannshausen, S.O. Stock, A. Borovik Jr. and T. Buhr, S. Fritzsche, M. Martins, A. Müller, S. Reinwardt, S. Ricz, F. Trinter and S. Schippers
141. EUV and X-ray induced ultrafast dynamics in He nanodroplets
M. Mudrich, D. Schomas, C. Medina, L. Ben Ltaief, A.C. LaForge, P. O'Keeffe, C. Callegari, Y. Ovcharenko, K.C. Prince, T. Möller and F. Stienkemeier
142. Correlated decay processes in pure and doped He nanodroplets probed by synchrotron radiation
M. Mudrich, A.C. LaForge, M. Shcherbinin, L. Ben Ltaief, R. Richter and T. Pfeifer
143. Chemistry beyond the crystal: Equilibrium solution phase structure from X-ray total scattering
S.A.J. Kimber and D. Szczerba
144. Time dependent atomic physics with non-thermal electron population for isochorically heated matter
P. Velarde
145. Direct Temperature Measurements in Solids via Inelastic X-ray Scattering under Shock and Ramp Compression
O. Karnbach, D. McGonegle, U. Zastra, T. White, E. McBride, S. Glenzer, J. Hastings, J. Eggert, R. Rudd, G. Gregori and J. Wark
146. Energy and atomic number dependencies for the one- and two-photon absorption mechanism
K. Tyrala, J. Czaplá-Masztafiak, A. Wach, W. Blachucki, K. Wojtaszek, W. Stanczyk, W.M. Kwiatek and J. Szlachetko

147. Setup and characterization of a helium liquid jet for diffraction experiments
K. Kolatzki, R.M.P. Tanyag, G. Noffz, A. Ulmer, T. Möller and D. Rupp
148. Triethylphosphine as a molecular gear - phase transitions in ferrocenyl-acetylide-gold(I)
A. Makal
149. Crystal structures and spectroscopic properties in polymorphs of 1,8-diacetylpirene
A. Makal and D. Tchoń
150. *K*-shell photoionization of silicon ions
T. Buhr, S. Stock, A. Perry-Sassmannshausen, S. Reinwardt, M. Martins, S. Ricz, A. Müller, S. Fritzsche and S. Schippers
151. Collective spontaneous emission: theoretical approaches and application to He superfluorescence
V. Sukharnikov and A. Benediktovitch
152. The effect of CRLs' properties on the depolarization of X-ray beam
Q. Yu
153. Surface dynamics of solids upon high-intensity laser irradiation investigated by GISAXS
L. Randolph, M. Banjafar, F. Schon, N. Dover, S. Göde, Y. Inubushi, G. Jakob, J. Kaa, M. Kläui, J. Koga, A. Kon, D. Ksenzov, M. Makita, T. Matsuoka, M. Nishiuchi, T. Preston, C. Rödel, Y. Sentoku, K. Sueda, T. Togashi, M. Vafae-Khanjani, T. Yabuuchi, U. Zastra, T. Cowan, T. Kluge, M. Busmann, C. Fortmann-Grote, C. Gutt and M. Nakatsutsumi
154. A Direct Measurement of the Temperature Evolution of Laser-Compressed Argon using First Principles Methods
E.E. McBride, A. Descamps, L.B. Fletcher, T.G. White, F. Condamine, C.B. Curry, E. Galtier, E. Gamboa, M. Gauthier, D.O. Gericke, S. Goede, J.B. Kim, B. Nagler, B.K. Ofori-Okai, M. Oliver, A. Rigby, C. Schoenwaelder, P. Sun, B.B.L. Witte, J. Hastings, G. Monaco, G. Gregori and S.H. Glenzer
155. Ultrafast structural dynamics of photo-reactions observed by time-resolved X-ray cross-correlation analysis
P. Vester
156. Phase stabilities of MgCO₃ polymorphs studied by Raman spectroscopy and X-ray diffraction and DFT
J. Binck, L. Bayarjargal, S. Lobanov, W. Morgenroth, R. Luchitskaia, C. J. Pickard, V. Milman, K. Refson, D. Jochym, P. Byrne and B. Winkler
157. Sequential resonant multi-photon processes in Xenon
T. Wagner, S. Klumpp, M. Kuhlmann, K. Mertens, M. Richter, M. Ruiz-Lopez, A. Sorokin, K. Tiedtke and M. Martins
158. Femtosecond laser-produced periodic plasma in a colloidal crystal probed by XFEL radiation
N. Mukharamova, S. Lazarev, J.-M. Meijer, O. Yu. Gorobtsov, A. Singer, M. Chollet, M. Busmann, D. Dzhigaev, Y. Feng, M. Garten, A. Huebl, T. Kluge, R.P. Kurta, V. Lipp, R. Santra, M. Sikorski, S. Song, G. Williams, D. Zhu, B. Ziaja-Motyka, T. Cowan, A.V. Petukhov and I.A. Vartanyants
159. Proton Buffered Explosion of Methane Clusters
A. Heilrath, D. Assalauova, I. Baev, S. Bari, T. Baumann, J. Bielecki, R. Boll, C. Bosted, T. Burian, A. Chatterley, A. Colombo, J. Crespo López-Urrutia, A. Ehresmann, B. Erk, S. Erukala, A. de Fanis, A. Feinberg, A. Feist, T. Fennel, D. Galli, L. Gelisio, O. Gessner, T. Gorkhover, P. Grychtol, L. He, D. Holzinger, D. Horke, A. Ignatenko, M. Ilchen, B. von Issendorff, M. Izquierdo, P. Johnsson, L. Juha, T. Kierspel, A. Knie, K. Kolatzki, S. Kuschel, J. Küpper, T. Laarmann, B. Langbehn, B. Langer, D. Lapkin, F. Maia, T. Mazza, M. Meyer, R. Michiels, J. Montaña, S. O'Connell, Y. Ovcharenko, C. Peltz, J. Peschel, P. Piseri, D. Rivas, E. Ruehl, U. Saalman, C. Saladrigas, M. Sauppe, P. Schmidt, B. Schütte, L. Schwob, H. Stapelfeldt, J. Stellhorn, F. Stienkemeier, R. Tanyag, N. Timneanu, S. Trippel, A. Ulmer, I. Vartanyants, A. Vilesov, P. Walter, Y. Yong Kim, P. Ziolkowski, M. Ware, T. Möller and D. Rupp

Made in Germany since 1992



DC-Power Supplies

- Easy and safe operation
- Interchangeable interfaces
- Arc handling with automatic parameter setting



Unipolar Pulse Generators

- Compact design
- Equipped for synchronization
- Very fast, fully automatic arc handling



Bipolar Pulse Generators

- Precise regulated power of both half waves for symmetrical and asymmetrical operation
- Very fast, fully automatic arc handling
- Very easy operation through automatic setting of pulse-on and pulse-off time



**ADL Analoge & Digitale
Leistungselektronik GmbH**

Bunsenstrasse 30 | 64293 Darmstadt | Germany
Tel. +49 (0) 6151 86072-0 | Fax +49 (0) 6151 86072-70
E-Mail: kontakt@adl-gmbh.com | www.adl-gmbh.com



Goodfellow
Your global supplier for materials

www.goodfellow.com | info@goodfellow.com | 0800 1000 579

160. X-ray-induced ignition of a helium nanoplasma
C. Medina, D. Schomas, M. Debatin, L. Ltaif, S. Krishnan, S. Mandal, T. Pfeifer, A. Heidenreich and F. Stienkemeier
161. A Radiative-Collisional Model with Non-Thermal Electrons and Ions Interacting with X-ray Lasers in Hot-Dense Plasma
Y. Shi
162. Gas phase and low temperature plasma core excitation using EUV/SXR laser produced plasma source
A. Bartnik, L. Varvarezos, P. Wachulak, H. Fiedorowicz, W. Skrzeczanowski, T. Fok, R. Jarocki and L. Wegrzynski
163. Surface Composition of Free-Flying Sea Spray Aerosol
I. Unger, G. Gopakumar, M. Patanen, C.-M. Saak, P. Zieger, M. Salter and O. Björneholm
164. The Small Quantum Systems (SQS) Instrument at European XFEL
T.M. Baumann, R. Boll, A. De Fanis, P. Grychtol, M. Ilchen, T. Mazza, J. Montano, V. Music, Y. Ovcharenko, N. Rennhack, D. Rivas, A. Roerig, P. Schmidt, S. Usenko, P. Ziolkowsky and M. Meyer
165. High-resolution resonant photoexcitation spectroscopy and metrology with highly charged ions
R. Steinbrügge, S. Kühn, P. Micke, T. Stöhlker, J. R. Crespo López-Urrutia and S. Bernitt
166. Ab-initio description of electronic states in matter excited with ultrashort intense X-ray pulses - Preliminary Results
J.J. Bekx, S.-K. Son, R. Santra and B. Ziaja
167. Controlled molecules
S. Kerbstadt, E. Karamatskos, M. Johny, S. Trippel and J. Küpper
168. Mapping the electronic structure of warm dense Nickel via resonant inelastic X-ray scattering
O.S. Humphries, R.S. Marjoribanks, Q. van den Berg, E.C. Galtier, M.F. Kasim, H.J. Lee, A.J.F. Miscampbell, B. Nagler, R. Royle, J.S. Wark and S.M. Vinko
169. Creating and detecting and controlling dynamically chiral molecules
E. Zak, A. Yachmenev and J. Küpper
170. Dynamics of the hydrogen bond
V. Balandin, B. Beutner, F. Brinker, W. Decking, M. Dohlus, L. Froehlich, U. Jastrow, R. Kammering, T. Limberg, D. Noelle, M. Scholz, A. Sorokin, K. Tiedtke, M. Yurkov, I. Zagorodnov, J. Liu, L. Samoylova, U. Boesenberg, W. Freund, J. Grünert, A. Koch, N. G. Kujala, T. Maltezopoulos, M. Messerschmidt, I. Petrov, H. Sinn and J. Küpper
171. Descriptors of XANES spectra
A. Algasov, S.A. Guda, A. Martini, A.A. Guda and A.V. Soldatov
172. Maximum Elliptical Dichroism in Atomic Two-Photon Ionization
J. Hofbrucker, A.V. Volotka and S. Fritzsche
173. Fluorescence polarization as a precise tool for understanding nonsequential many-photon ionization
J. Hofbrucker, A.V. Volotka and S. Fritzsche
174. A gas-phase soft X-ray study on the metal active site of metalloporphyrins and metalloproteins
K. Schubert, K. Atak, L. Schwob, S. Dörner, C. Bülow, T. Lau, S. Techert, M. Timm, X. Wang, V. Zamudio-Bayer, T. Schlathölter and S. Bari
175. Photoelectron momentum images of molecular structure
J. Onvlee, J. Wiese, E.T. Karamatskos, S. Trippel and J. Küpper
176. Complex fragmentation dynamics of multiply charged fullerenes and clusters
Z. Jurek, S.-K. Son, B. Ziaja and R. Santra

177. Photon-energy dependent ionisation of isolated Xenon atoms
T. Baumann, R. Boll, M. Ilchen, J. Laksman, T. Mazza, M. Meyer, V. Music, D. Rivas, A. Rörig, S. Serkez, P. Schmidt, S. Usenko, J. Schäfer, R. Santra, Sang-Kil Son, S. Pathak, D. Rolles and B. Erk
178. X-ray spectroscopy of ultrafast-decaying core-excited ionic states in atoms
T. Mazza, M. Ilchen, T. Baumann, R. Boll, A. De Fanis, P. Grychtol, V. Music, Y. Ovcharenko, D. Rivas, N. Berrah, B. Erk, E. Gryzlova, P. Johnsson, M. Kiselev, C. Küstner-Wetekam, L. Marder, M. Martins, Ch. Ott, S. Pathak, Th. Pfeifer, D. Rolles, P. Schmidt, A. Grum-Grzhimailo and M. Meyer
179. Small angle X-ray scattering probing ultrashort pulse high-intensity laser-solid interactions
L. Gaus, M. Rödel, M. Bussmann, E. Galtier, A. Laso García, M. Garten, S. Glenzer, C. Gutt, Hae Ja Lee, J. Metzkes-Ng, B. Nagler, A. Pelka, I. Prencipe, C. Rödel, H.-P. Schlenvoigt, T. Cowan, U.Schramm and T. Kluge
180. Inverse Participation Ratio Calculations of Localization States in Aluminium
T.D. Gawne and S.M. Vinko
181. *In operando* soft X-ray studies of the plasma-solid interface with PISA
F. Diekmann, J. Buck, N. Benthien, M. Kalläne, S. Rohlf, F. Trinter, M. Klette, T. Trottenberg and K. Roßnagel
182. Cryogenically-cooled and controlled beams of nanoparticles and biomolecules
L. Worbs, J. Lübke, H. Akarsu, M. Amin, A. Estillore, A. K. Samanta and J. Küpper
183. High Resolution Mass Spectrometry and Velocity Map Imaging for Ultrafast Electron Dynamics in Biomolecules
K. Saraswathula and E.P. Maansson
184. Pump-probe experiments at the SQS instrument of the European XFEL
T. Baumann, R. Boll, A. De Fanis, J. Grünert, P. Grychtol, M. Ilchen, J. Liu, T. Mazza, J. Montaña, V. Music, Y. Ovcharenko, N. Rennhack, D. Rivas, P. Schmidt, S. Usenko, R. Wagner, P. Ziolkowski and M. Meyer
185. A CEP-stable and multi-mJ OPA for attosecond pulse generation in the soft-X
G. Giovannetti, A. Cartella, D. Faccialà, C. Manzoni, L. Colaizzi, A. Trabattoni, C. Vozzi and F. Calegari
186. Near edge X-ray absorption mass spectrometry on peptides in the gas phase: From site-specific excitation to site-selective dissociation
S. Dörner, L. Schwob, K. Schubert, K. Atak, C. Bülow, T. Lau, T. Schlathölter, M. Timm, V. Zamudio-Bayer, X. Wang, S. Techert and S. Bari
187. X-ray Absorption Spectroscopy of Protonated Waterclusters and Solvated Ions
J. Schwarz, F. Kielgast, I. Baev, S. Reinwardt, F. Trinter and M. Martins
188. Pyrene and a Test Case for DeepUV Molecular Photophysics
A. Picchiotti, A. Nenov, A. Giussani, V. Prokhorenko, D. Miller, S. Mukamel and M. Garavelli
189. Resistivity potential wall theory in laser plasma interaction
Y. Long, T. Cowan, L. Huang and H. Takabe
190. Time-dependent inner-shell photoelectron binding energies probed by electron-ion partial covariance imaging
F. Allum, P. Schmidt, V. Music, G. Hartmann, T.M. Baumann, R. Boll, G. Brenner, M. Burt, P. Demekhin, S. Doerner, A. Ehresmann, B. Erk, P. Grychtol, D. Heathcote, L. Inhester, D. Kargin, J. Lee, M. Larsson, Z. Li, B. Manschwetus, M. Meyer, L. Marder, R. Mason, H. Otto, C. Passow, R. Pietschnig, D. Ramm, D. Rolles, K. Schubert, L. Schwob, R. Thomas, C. v. Korff-Schmising, C. Vallance, I. Vidanoic, R. Wagner, V. Zhaunerchyk, A. Knie, M. Brouard and M. Ilchen
191. Theoretical Investigation of XFEL-Induced Coulomb Explosion Dynamics
J.M. Schäfer, R. Boll, Z. Jurek, M.M. Abdullah, G. Kastirke, M. Schöffler, M. Meyer, S.-K. Son, R. Santra and T. Jahnke

192. Towards controlling the photorelaxation in Fe complexes
G. Vankó, Z. Németh, T. Keszthelyi, T. Rozgonyi, M. Papp, D. Sárosiné Szemes, G. Bazsó, D. Khakhulin, W. Gawelda, C. Bressler, F. Lima, E. Biasin, T.B. van Driel, M.M. Nielsen, K. Haldrup and M. Pápai
193. Self-sustained reaction oscillations in a new light
U. Hejral, S. Albertin, S. Pfaff, J. Zhou, M. Shipilin, S. Blomberg, O. Gutowski, A.-C. Dippel, J. Zetterberg, J. Gustafson and E. Lundgren
194. XUV-absorption from aligned molecular ions
S. Reinwardt, T. Buhr, A. Perry-Sassmannshausen, F. Trinter, A. Müller, S. Schippers, S. Klumpp and M. Martins
195. Imaging via spatial-incoherent X-ray fluorescence
F. Trost, K. Ayyer and H. Chapman

III.4 Biology and life sciences

196. Damage to (bio)organic molecules in water exposed to ultraviolet and extreme ultraviolet and soft X-ray radiation in and out of the water window
L. Vysin, V. Hajkova, T. Burian, M. Davidkova, M. Krus, V. Cuba, K. Tomanova, H. Fiedorowicz, A. Bartnik, P. Wachulak, J.J. Rocca and L. Juha
197. Studying of effects of accelerated charged particles on skin cancer cells
S. Danova, Y. Illieava, H. Najdensky, I. Tsakov and M. Zaharieva
198. Examination of copper (II) compounds with the use of laboratory XAS setup for biological applications
W. Stanczyk, J. Czaplá-Masztafiak, J. Szlachetko, W. Blachucki, A. Wach, M. Nowakowski and W. M. Kwiatek
199. Structure analysis of the aptamer - cancer cells magnetic separation agent
R.V. Moryachkov, G.S. Zamay, I.A. Shchugoreva, V.N. Zablude, A.E. Sokolov, E.A. Moryachkova, D.S. Molodenskiy and A.S. Kichkailo
200. Cochleate Structures: a SAXS/WAXS Investigation
P. Garidel and S. Funari
201. High pressure XPCS on dense protein solutions
M. Moron, C. Lovato, A. Al-Masoodi, L. Randolph, M. Reiser, J. Möller, F. Westermeier, M. Paulus, M. Tolan and C. Gutt
202. Multi-scale X-ray phase contrast tomography of murine hearts
M. Reichardt, J. Frohn, A. Khan, F. Alves and T. Salditt
203. 3D virtual histology of the human hippocampus by holo-tomography
M. Eckermann, M. Töpperwien, A.-L. Robisch, F. van der Meer, C. Stadelmann and T. Salditt
204. Multi-scale 3D virtual histology via phase-contrast X-ray tomography on human pancreatic tissue at GINIX/P10
J. Frohn, J. Missbach-Guentner, D. Pinkert-Leetsch, F. Alves and T. Salditt
205. Structural Dynamics Correlation of Peptides derived from Nups: Time-resolved X-ray Scattering and Computational Modelling
N. Biswas, K. Basuroy, J. Soltau, M. Osterhoff, M. Sander, M. Levantino, M. Wulff and S. Techert
206. OnDA: Online Data Analysis And Feedback For Serial X-ray Imaging
V. Mariani, A. Morgan, C.H. Yoon, T.J. Lane, T.A. White, C. O'Grady, M. Kuhn, S. Aplin, J. Koglin, A. Barty and H.N. Chapman
207. Time-resolved XES studies on photosystem II and manganese model compounds
V. Mazalova, G. Subramanian, P. Schwander, A. Ourmazd and P. Fromme

208. Dynamics of pressure-induced phase transition in concentrated lysozyme solutions measured by XPCS
A. Al-Masoodi, C. Lovato, M. Moron, J. Bolle, G. Surmeier, L. Randolph, M. Reiser, J. Möller, F. Westermeyer, M. Paulus, M. Tolan and C. Gutt
209. Local resolution estimation for 3D reconstructions in SPI experiments
K. Ikonnikova, A. Teslyuk, S. Bobkov, S. Zolotarev, T. Baymukhametov, Y. Chesnokov, V. Ilyin and I. Vartanyants
210. Approach to high-resolution single particle imaging at an X-ray free-electron laser
D. Assalauova, Y.Y. Kim, S. Bobkov, M. Rose, SPI consortium @ LCLS, A. Aquila and I.A. Vartanyants
211. Dynamics of Arrested Phase Transition in Immunoglobulin G (IgG) studied by USAXS- and SAXS-XPCS
H. Rahmann, M. Akhundzadeh, A. Girelli, N. Begam, A. Ragulskaaya, M. Reiser, J. Möller, F. Westermeyer, M. Sprung, A. Becker, K. Lopata, C. Lovato, S. Timmermann, A. Al-Masoodi, F. Zhang, F. Schreiber and C. Gutt
212. SAXS Experiments by Turkish BAG at EMBL P12 beamline
T. Cheremnykh and H. Mertens
213. Phase-contrast X-ray tomography of marmoset cochlea
J. Schaeper, M. Reichardt, M. Eckermann, J. Frohn, C. Kampshoff and T. Moser
214. High-throughput scanning SAXS of mouse fibroblasts
C. Cassini, M. Burghammer and S. Köster
215. Kinetics of ice formation during cryogenic cooling of monoolein/protein/salt/water system
I. Baranova, A. Angelova, W. Shepard, J. Andreasson and B. Angelov
216. On-chip crystallization and ligand binding for serial crystallography experiments
J. Lieske, M. Cerv, S. Kreida, M. Barthelmess, P. Fischer, T. Pakendorf, O. Yefanov, V. Mariani, T. Seine, B.H. Ross, E. Crosas, O. Lorbeer, A. Burkhardt, S. Günther, J. Bergtholdt, S. Schön, S. Törnroth-Horsefield, H.N. Chapman and A. Meents
217. High-pressure X-ray crystallography
J. Lieske, S. Guenther, S. Saouane, J. Meyer, T. Pakendorf, B. Reime, A. Burkhardt, E. Crosas, J. Hakanpaeae, M.H. Abdellatif, H.N. Chapman and A. Meents
218. X-ray nanoscopy of the elemental distribution in endothelial cells
J. Heym, L. Lühl, S. Twamley, A. Ludwig, A. Dehlinger, J. Grage, A. Haidl, C. Seim, B. Kanngießer and T. Wilhein
219. Hard X-ray Phase Contrast Imaging of Black Lipid Membranes
H. Bruns, K. Frank, J. Nicolas and T. Salditt
220. Studying DNA in Cell Nuclei by Combined X-ray Scanning Nanodiffraction and Holography
A. Wittmeier, C. Cassini, M. Töpperwien, M. Denz, J. Hagemann, M. Osterhoff, T. Salditt and S. Köster
221. High-throughput X-ray imaging and tomography in EMBL Hamburg
M. Polikarpov, G. Bourenkov, A. Snigirev and T. Schneider
222. Determination of the Relative Positions of the Helices in Bacteriorhodopsin Macromolecule Basing on X-ray Diffraction Data with the Use of Convolutional Neural Networks
K. Shaitan, M. Lozhnikov, V. Novoseletsky, G. Armeev, A. Kudriavtsev, G. Kobelkov and A. Shaytan
223. NEXAFS and XPS studies of the carbonized bath sponge scaffold and nanostructured 3D copper-carbon catalyst
O. Petrova, S. Nekipelov, V. Sivkov, S. Molodtsov and H. Ehrlich

224. Pineal gland research with high resolution 3D imaging techniques
I. Bukreeva, V. Asadchikov, A. Buzmakov, M. Chukalina, A. Ingacheva, F. Palermo, A. Cedola and M. Fratini
225. Serial diffraction data collection from reaction center crystals using Roadrunner chip delivery technique
G. Selikhanov, S. Guenther, T. Fufina, L. Vasilieva A. Meents and A. Gabdulkhakov
226. Analysing structure and function and dynamics of industrially important enzymes from *Nectria haematococca*
H. Andaleeb, H. Brognaro, M. Perbandt and C. Betzel
227. X-ray fluorescence analysis of cryogenically fixated hydrated biological samples with large-acceptance-angle SDD detection at P06
A. Gräfenstein, C. Rumancev, T. Vöpel, S. Stuhr, A.R. von Gundlach, T. Senkbeil, J. Garrevoet, G. Falkenberg, S. Ebbinghaus, W.H. Schroeder and A. Rosenhahn
228. Structure-Function-Analysis of vital Proteins from Antibiotic Resistent Bacteria towards Drug Discovery
M. Schwinzer
229. SASBDB: Towards an automatically curated and validated repository for biological scattering data
A.G. Kikhney, C.R. Borges, D.S. Molodenskiy, C.M. Jeffries and D.I. Svergun
230. Ice formation in cell freezing media
A. Ivanova, O. Yefanov, I. Sarrou, E. Simonenko and H. Chapman
231. XFEL diffraction patterns from tick-borne encephalitis virus particles: simulations vs experiments
G.A. Armeev, A.K. Shaytan, D.I. Osolodkin, A.M. Egorov, A.A. Ishmukhametov, K.V. Shaitan and M.P. Kirpichnikov
232. Biocrystallography at beamline P11
J. Hakanpää, E. Crosas, S. Saouane, J. Meyer, J. Urbschat, B. Reime, A. Meents and A. Burkhardt
233. Structure-Function-Analysis of Vital Proteins from Antibiotic Resistent Bacteria towards Drug Discovery
B. Alves França, M. Schwinzer, C. Yildiz, H. Rohde and C. Betzel
234. The Effect of Entanglement on Nanoscale Diffusion Dynamics in Complex Fluids Studied by XPCS
M. Reiser, J. Hallmann, J. Möller, D. Orsi, L. Randolph, H. Rahmann, A.L. Becker, L. Cristofolini, C. Gutt and A. Madsen
235. Bone quality during skeletal development: structural and compositional adaptations on the micro- and nanoscale
K. Stockhausen, F. Schmidt, E. Wölfel, M. Qwamizadeh, M. Schwartzkopf, S. Roth and B. Busse
236. Mix-and-diffuse serial synchrotron chryystallography
D. Oberthuer
237. Neural networks for small angle scattering data analysis
D. Molodenskiy, A. Kikhney and D. Svergun
238. Single particle diffraction observed for tick-borne encephalitis virus at EuXFEL experiment 2316
M.F. Vorovich, V.R. Samygina, E.B. Pichkur, J. Bielecki, E.V. Khvatov, A.Y. Fedotov, A.L. Ivanova, K.K. Tuchynskaya, O.I. Konyushko, D.I. Osolodkin, A. Mancuso, F.R.N.C. Maia, A.M. Egorov, A.A. Ishmukhametov and the SPB/SFX single particle community for proposal 2316
239. Mössbauer studies of minerals transformations by extremophilic microorganisms
A. Antonova, N. Chistyakova, D. Zavarzina, S. Gavrilov and V. Rusakov

TRIPOD - A new modular parallel kinematic series

Movement control in up to 6 dof with nanometer resolution

Continuous rotation and long travel for x and y

Easy integration into existing setups

User definable Pivot Point and programmable in Cartesian Coordinates

Non-magnetic and (ultra-) high vacuum compatible versions available

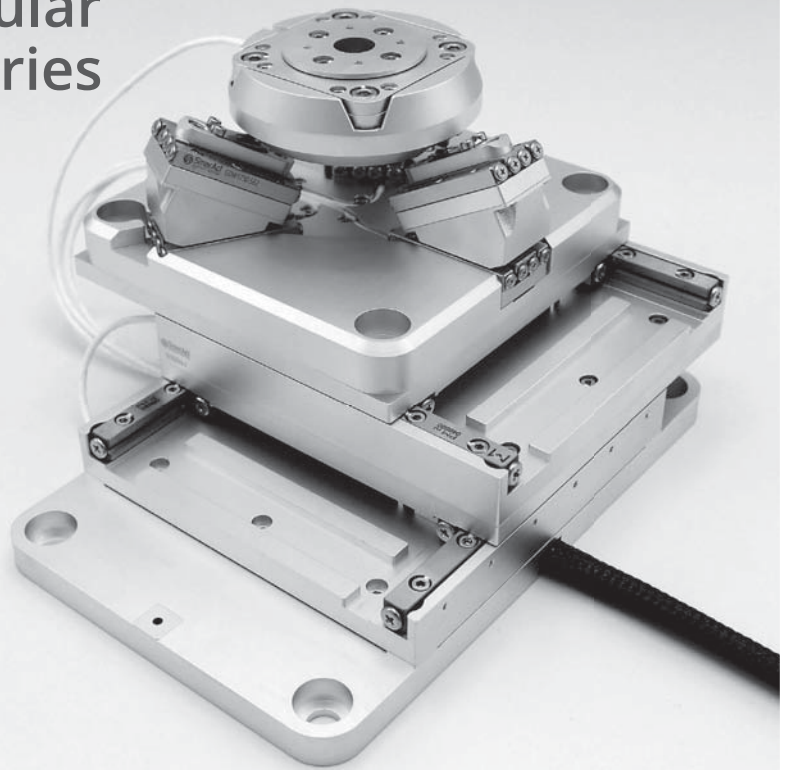

For high precision matters.

www.smaract.com

SYDOR
TECHNOLOGIES

COMPLEX MEASUREMENTS
CRITICAL RESULTS

MHz Imaging Rates!

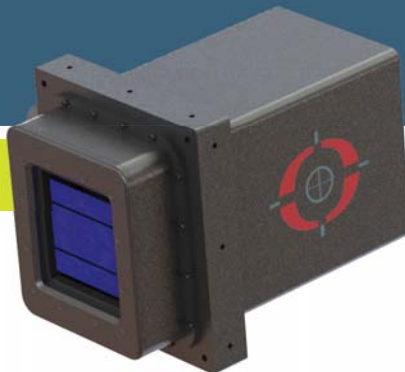

The **Sydor Keck PAD** provides the ultimate flexibility for direct x-ray imaging detectors.

For the most demanding time-resolved studies, the detector can operate in burst mode with framing up to 9 MHz. For more standard experiments, units can be configured in a continuous framing mode, running at 1 KHz.

The PAD detector is available with Si or CdTe sensors.

Standard pixel modules are tiled in 512x512 layouts and may be customized upon request.

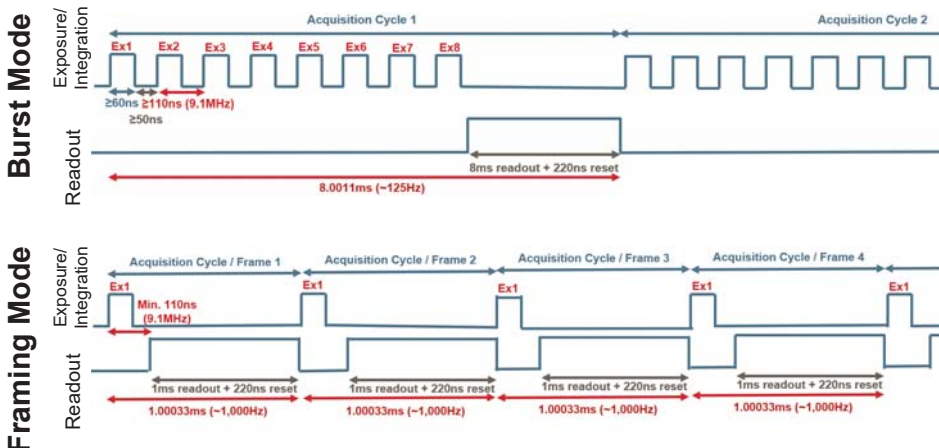

Visit SydorTechnologies.com for more information!

240. Monitoring formation and structure and dynamics of liquid dense protein clusters under distinct physico-chemical conditions
S. Falke, M. Wang, H. Brognaro, C. Nzanzu Mudogo and C. Betzel
241. Liquid-Liquid Phase Separation of the Alzheimer Protein Tau
C. Exner, J. Hochmair, S. Falke, S. Wegmann, E. Mandelkow and C. Betzel
242. Structure-Function Analysis of the the PLP Synthases from *P. vivax* and *S. aureus* towards drug discovery
N. Ullah, C.N. Mudogo, S. Falke, M. Perbandt, C. Wrenger and C. Betzel
243. Targeting Structure and Dynamics of Ligand binding to a vital bacterial Beta-Lactamase by serial mix-and-diffuse and conventional crystallography towards Drug Discovery
A. Prester, N. Werner, K. Zielinski, J. Maracke, V. Mariani, O. Yefanov, H. Fleckenstein, M. Aepfelbacher, H. Chapman, C. Betzel, D. Oberthuer, H. Rohde and M. Perbandt
244. A robotic transfer system for automatically harvested protein crystals
M. Bueno, T. Gehrmann, D. Jahn, L. Kolwicz-Chodak, J. Meyer, S. Panneerselvam, U. Ristau and S. Fiedler
245. Actomyosin structure in living cardiomyocytes studied by micro-diffraction
C. Neuhaus, M. Reichardt, J. Nicolas and T. Salditt
246. Structural studies on in cellulo crystallized *Trypanosoma brucei* GMP reductase
M. Bueno, T. Gehrmann, D. Jahn, L. Kolwicz-Chodak, J. Meyer, S. . Panneerselvam, U. Ristau, S. Fiedler, K. Volckaert, L. Freise, S. Nachtschatt, R. Schönherr, M. Duszenko, D. v. Stetten and L. Redecke
247. Native mass spectrometry for single particle imaging with an XFEL
A. Kadek, Y. Lu, K. Lorenzen and C. Uetrecht for MS-SPIDOC consortium
248. A new cloning system for efficient in cellulo crystallization.
R. Schönherr, S. Nachtschatt and L. Redecke
249. High-Resolution Pump-Probe X-ray Holography of Cavitation Dynamics at the European XFEL
M. Vassholz, H.P. Hoeppe, J.M. Rosselló, J. Hagemann, M. Osterhoff, R. Mettin, A. Schropp, C.G. Schroer, J. Möller, A. Madsen, MID-Team and T. Salditt
250. Investigation of the structure of photoswitchable lipid monolayers
S. Hövelmann, J. Kuhn, J. Warias, R. Giri, A. Sartori, P. Jordt, C. Shen, F. Reise, T. Lindhorst, O. Magnussen and B. Murphy
251. Ice Nucleation in Supercooled Water Droplets
N. Esmaeildoost, H. O. Jönsson and J. A. Sellberg
252. In cellulo crystallization of protein complexes
J. Boger, A. S. Ferreira-Ramos, R. Schönherr and L. Redecke
253. Integrated Biology Infrastructure Life-Science Facility at the European X-ray Free Electron Laser (XBI) - From idea to successful operation
M. Äpfelbacher, I. Barák, C. Betzel, P. Fromme, Y. G ul, J. Hajdu, H. Han, I. Kursula, K. Lorenzen, J. Makroczyová, E. Round, K. Saksl, R. Schubert, J. Schulz, P. Sovák, J. Uličníý and M. Wilmanns
254. T-REXX: the endstation for serial time-resolved crystallography on the EMBL beamline P14 on PETRA III
D. von Stetten, M. Agthe, G. Bourenkov, M. Polikarpov, S. Horrell, B.A. Yorke, G.S. Beddard, M. Nikolova, I. Karpics, T. Gehrmann, J. Meyer, U. Ristau, S. Fiedler, D.C.F. Monteiro, M. Trebbin, P. Mehrabi, E.C. Schulz, F. Tellkamp, R.J.D. Miller, N. Huse, A.R. Pearson and T.R. Schneider

255. Cavitation Dynamics Studied by X-ray Holography at MID and European XFEL and GINIX and PETRA III
H.P. Hoeppe, M. Vassholz, J.M. Rosselló, J. Hagemann, M. Osterhoff, R. Mettin, A. Schropp, C.G. Schroer, J. Möller, A. Madsen, MID Team and T. Salditt
256. Structure of S1 ribosomal protein
S.Yu. Grishin, U.F. Jus, O.M. Selivanova, A.K. Surin and O.V. Galzitskaya
257. Time Resolved Crystallography: Optical-control of Photoisomerisation Populations in a Reversibly Switchable Fluorescent Protein
J. Baxter
258. To store or not to store raw SFX data?
O. Yefanov, A. Ivanova, N. Luybaykina, O. Oberthuer, A. Tolstikova, T. White, A. Barty and H.N. Chapman
259. X-ray Reflectivity Investigation of Structure and Kinetics of Photoswitchable Lipid Monolayers
J. Varias, S. Hövelmann, M. Jacobsen, F. Reise, A. Sartori, R. Giri, C. Shen, T. Lindhorst, O. Magnussen and B. Murphy

III.5 Films, surfaces and interfaces

260. HAXPES study of interface chemical states and barriers at GaP/Si(001) heterointerfaces
O. Romanyuk, A. Paszuk, R.G. Wilks, O. Supplie, J. P. Stoeckmann, J. Bombsch, C. Hartmann, R. Garcia-Diez, S. Ueda, I. Bartož, I. Gordeev, J. Houdkova, P. Kleinschmidt, M. Bär, P. Jiříček and T. Hannappel
261. Electrodeposition on liquid metals: In-situ X-ray studies
A. Sartori, Q. Cheek, R. Giri, S. Maldonado, O. Magnussen and B. Murphy
262. Improving Exchange Bias via Oblique Incidence Deposition
T. Gurieva, K. Schlage, L. Bocklage, S. Willing, M. Ramin Moayed and R. Röhlberger
263. Dynamics of interfacial electron-hole separation in an organic heterojunction monitored by femtosecond time-resolved X-ray photoelectron spectroscopy
F. Roth, M. Borgwardt, L. Wenthaus, J. Mahl, S. Palutke, G. Brenner, S. Molodtsov, W. Wurth, O. Gessner and W. Eberhardt
264. New insights into the laser-assisted photoelectric effect from solid state surfaces
M. Borgwardt, F. Roth, L. Wenthaus, J. Mahl, S. Palutke, G. Brenner, S. Molodtsov, W. Eberhardt and O. Gessner
265. Operando Surface X-ray Diffraction Studies of Structurally-defined Co_3O_4 and CoOOH Thin Films during Oxygen Evolution: pH dependence
C. Qiu, F. Reikowski, F. Maroun, I. Pacheco, M. Bouvier, T. Wiegmann, P. Allongue, J. Stettner and O.M. Magnussen
266. Combining grazing incidence X-ray and neutron scattering for cellulose thin films
C.J. Brett, M. Gensch, W. Ohm, N. Mittal, L.P. Kreuzer, V. Körstgens, M. Månsson, P. Müller-Buschbaum, L.D. Söderberg and S.V. Roth
267. Noble metal nanoparticles in organic matrix CuPcF_x ($x=0$ and 4)
O.V. Molodtsova, I.M. Aristova, D.V. Potorochin, S.V. Babenkov, I.I. Khodos, S.L. Molodtsov, M. Vorokhta, T. Skála and V.Y. Aristov
268. Controllable growth of few-layer graphene on SiC(001)/Si wafers
V. Aristov, A. Chaika, O. Molodtsova, S. Babenkov, D. Potorochin, A. Locatelli, T. Montes, A. Sala and D. Marchenko

269. Sputter deposition of Ag on nanostructured PMMA-b-P3HT copolymer thin films
M. Gensch, M. Schwartzkopf, S.J. Schaper, L.P. Kreuzer, N. Li, J. Drewes, O. Polonskyi, T. Strunskus, F. Faupel, P. Müller-Buschbaum and S.V. Roth
270. In-situ printing of PBDB-T-SF and IT-4F for application in high-efficiency organic solar cells
K.S. Wienhold, V. Körstgens, S. Grott, X. Jiang, M. Schwartzkopf, S.V. Roth and P. Müller-Buschbaum
271. Imaging the phase transition in thin film VO₂ microstructures
J. Schunck, F. Döring, B. Rösner, J. Buck, S. Mahatha, M. Hoesch, C. Schüssler-Langeheine, A. Petraru, H. Kohlstedt, K. Rossnagel, C. David and M. Beye
272. Damage to optics with femtosecond lasers: from visible to hard X-ray regime
I. Milov, V. Lipp, D. Ilitsky, N. Medvedev, K. Migdal, V. Zhakhovsky, V. Khokhlov, Yu. Petrov, N. Inogamov, S. Semin, A. Kimel, B. Ziaja, V. Medvedev, I. Makhotkin, E. Louis and F. Bijkerk
273. Ultrafast molecular orbital imaging of a pentacene thin film using a free-electron laser
M. Scholz, K. Baumgärtner, C. Metzger, D. Kutnyakhov, M. Heber, C.H. Min, T.R.F. Peixoto, M. Reiser, C. Kim, W. Lu, R. Shayduk, W.M. Izquierdo, G. Brenner, F. Roth, F. Pressacco, A. Schöll, S. Molodtsov, W. Wurth, F. Reinert and A. Madsen
274. Elasticity deformed state of thin diamond crystal as element of X-ray optics
R.V. Digurov and S. A. Terentyev
275. In-situ/Operando X-ray study of a Reversible PtO_x Formation at the Pt/YSZ interface.
S. Volkov, F. Bertram, P. Lakner, A. Hutterer, V. Vonk, J. Fleig, A. Stierle and O. Seeck
276. Photoelectron Spectroscopy of graphitic Carbon Nitride
M. Nissen, M. Taplick, I. Baev, C. Ruhmlieb, A. Mews and M. Martins
277. Influence of Different Organic Cation and Halide Combinations on the Crystallization Dynamics of Spin Coated Perovskite Thin Films
E. Kneschaurek, A. Hinderhofer and F. Schreiber
278. *In Operando* Soft X-ray Photoemission Spectroscopy of 2D Materials
S. K. Mahatha, A. Nierhauve, S. Rohlf, B. Schulte, F. Diekmann, J. Buck, M. Kalläne, G. Praedel, J. McIver and K. Rossnagel
279. Cellulose nanocomposite with SrFe₁₂O₁₉ nanoparticles as a novel magnetic nanopaper source
A. Chumakov, B. Calvin, Ar. Eliseev, E. Anokhin, L. Trusov, L. Akinsinde, M. Gensch, D. Menzel, M. Schwartzkopf, M. Rübhausen and S.V. Roth
280. Hyperfine interactions in ¹¹⁹Sn films probed via nuclear resonance scattering
S. Velten, L. Bocklage, D. Lemtrodt, K. P. Heeg, J. Gollwitzer, K. Schlage, I. Sergeev, H.-C. Wille, J. Evers and R. Röhlberger
281. Determination of mechanical properties of lipids using X-ray scattering
M. Scheu, K. Frank, K. Komorowski, M. Reichardt and T. Salditt
282. Quantification of voltage-induced anion incorporation in polypyrrole thin films by in situ X-ray reflectivity
P.H. Lakner, C. Seitz, S. Volkov, T.F. Keller, M. Brinker and P. Huber
283. Selection of the ferro- and antiferromagnetic phases in the top layer of [Fe/V] multilayer by Synchrotron Mössbauer reflectivity with polarization analysis
R.A. Baulin, M.A. Andreeva, L. Häggström, V.E. Asadchikov, B.S. Roshchin, A.I. Chumakov, D. Bessas and R. Ruffer
284. Time resolved study of core level and valence band dynamics in Bi₂Se₃ with angle-resolved photoelectron spectroscopy at FLASH
M. Heber, K. Kühlmann, D. Kutnyakhov, F. Pressacco, N. Wind, D. Curcio, K. Volckaert, Y. Acremann, Ph. Hofmann, K. Rossnagel and W. Wurth

285. Probing the antiferromagnetic-to-ferromagnetic phase transition of FeRh with femtosecond time-resolved small angle X-ray scattering and X-ray absorption spectroscopy
R. Carley, N. Agarwal, A. Yaroslavtsev, M. Izquierdo, L. le Guyader, L. Mercadier, N. Gerasimova, J. Schlappa, B. van Kuiken, R. Gort, G. Mercurio, M. Teichmann, D. Turenne, I. Vaskivskiy, J. Arregi, V. Ühler, Ch. Back, H. Dürr and A. Scherz
286. Strain and Stresses Evolution in Thin Films and Coatings Under Extreme Conditions and Its Relation to CRMs Problem
B.O. Postolnyi, L. Rebouta, J.P. Araujo and A.D. Pogrebnyak
287. Microfocus upgrade for spin- and angle-resolved photoemission spectroscopy using the ASPHERE III experiment endstation at branch 1 of the soft X-ray beamline P04
M. Kallaene, J. Buck, F. Diekmann, T. Figgemeier, Ph. Kagerer, S. Mahata, C.-H. Min, A. Nierhauve, T. Riedel, S. Rohlf, M. Uenzelmann, J. Viehhaus, H. Bentmann, F. Reinert and K. Rossnagel
288. Picosecond relaxation dynamics of FeRh observed using optical pump - nuclear resonance scattering probe experiments
S. Sadashivaiah, B. Eggert, M.E. Gruner, J. Landers, S. Salamon, T. Hochdörffer, R.A. Brand, W. Keune, K. Ollefs and H. Wende
289. Photoelectrons under pressure: investigation of operando Fischer-Tropsch catalysis above 1023hPa
P. Lömker, M. Shipilin, H. Noei, K. Ploner, C. Goodwin, J. Gladh, T. Götsch, N. Köpfle, Yu. Matveyev, A. Gloskovskii, K. Ederer, C. Schlueter, A. Nielsson and P. Amann
290. Observation of the near-surface diffusion of Fe₃O₄ (001) by nuclear forward scattering
S. Tober, J.C. Schober, E.E. Beck, G. Dalla Lana Semione, S. Chung, K. Schlage, O. Leupold, I. Sergeev, R. Steinbrügge, H.-C. Wille, H. Noei, V. Vonk and A. Stierle
291. Human antibacterial peptides modify lateral structure in lipid monolayers upon interfacial adsorption
C. Shen, T. Gustmann, B. Kloesgen, C. Nehls and L. Paulowski

III.6 Materials science

292. Ultrafast melting and crystallization of Pd
R. Sobierajski, P. Zalden, K. Sokolowski-Tinten, C. Bressler, M. Chojnacki, G. Evangelakis, A.R. Fernandez, K. Fronc, W. Gawelda, K. Georgarakis, A.L. Greer, R. Kaminski, D. Khakhulin, K. Kosyl, R.W.E. van de Kruijs, K. Kubicek, A. Olczak, N. Panagiotopoulos, M. Sikora, P. Sun, H. Yousef and J. Antonowicz
293. In operando diffraction radiography and tomography on Li-ion batteries
A. Schökel, A. Senyshyn and V. Baran
294. Ultrafast structural dynamics along a phase transition path
F. Vidal, Y. Zheng, L. Lounis, L. Coelho, C. Laulhé, C. Spezzani, A. Ciavardini, H. Popescu, E. Ferrari, E. Allaria, J. Ma, H. Wang, J. Zhao, M. Chollet, M. Seaberg, R. Alonso-Mori, J. Glownia, M. Eddrief and M. Sacchi
295. Luminescence of Ag nanoclusters in oxyfluoride glasses: XAS results
M.V. Shestakov, J. Vanacken, B. Dipanjan, L. Cibotaru and V.V. Moshchalkov
296. Non-equilibrium dynamics of soft matter using the European XFEL
F. Lehmkuhler, A. Dallari, A. Jain, M. Sikorski, J. Möller, L. Frenzel, I. Lokteva, G. Mills, M. Walther, H. Sinn, F. Schulz, M. Koof, V. Markmann, R. Bean, Y. Kim, P. Vagovic, A. Mancuso, A. Madsen and G. Grübel
297. The Phase Diagram of Colloidal Silica-PNIPAm core-shell Nanogels
L. Frenzel, F. Lehmkuhler, I. Lokteva, M. Koof and G. Grübel
298. Determination of crystal-field splitting mechanism during temperature programmed oxidation of Ti
K. Wojtaszek, A. Wach, W. Blachucki, K. Tyrala, M. Nowakowski, M. Zajac, J. Stepien, W. Stanczyk, J. Czaplá-Masztafiak, W.M. Kwiatek and J. Szlachetko

299. Characterization and Modelling of Deformation Mechanisms in Cement Hardened Paste by means of SAXS
M. Baum and M. Haist
300. Cation mixing and defect states study of (Mg and Zn)Al₂O₄ nanocrystals
M. Jain, A. Vij and A. Thakur
301. Ion irradiation effect on the microstructure of Inconel 625 obtained with additive manufactured 3D printing and with conventional technique
I. Cieřlik, T. Płociński, M. Duchna, A. Azarov, E. Wyszowska, A. Azarov and M. Zieniuk
302. Corrosion investigation of Inconel 713C cast and 3D form
M. Duchna, I. Cieřlik, J. Ferenc, A. Kosińska and J. Mizera
303. Anisotropic and heterogeneous dynamics in colloidal gels
A. Jain, F. Schulz, F. Lehmkuhler and G. Grübel
304. X-ray Cross Correlation Analysis of supercooled water
A. Jain, F. Lehmkuhler and G. Grübel
305. Mapping the twinning in multiferroic single crystals
I. Gudim, E. Ovchinnikova, K. Kozlovskaya, F. Wilhelm, V. Ivanov, A. Mukhin, V. Dmitrienko, A. Rogalev and M. Platonov
306. Investigations of polystyrene-fullerene nanocomposites thin films by neutron and X-ray reflectometry
M.L. Karpets, T.V. Tropin, Ye.N. Kosiachkin, I.V. Gapon, Yu.E. Gorshkova, M.V. Avdeev and L.A. Bulavin
307. Modification of Optical and Magneto-optical activity of Highly Textured Au₃Fe_{1-x}/Fe Janus-like Nanocrystals grown on amorphous silicon dioxide surface
I. Tarasov
308. 3D X-ray Diffraction Microscopy (3DXRD) using high resolution X-ray nanodiffraction
H. Stieglitz, J. Hektor, A. Davydok, C. Krywka and M. Müller
309. Femtosecond X-ray diffraction reveals a liquid-liquid phase transition in phase-change materials
P. Zalden, F. Quirin, M. Schumacher, J. Siegel, S. Wei, A. Koc, M. Nicoul, M. Trigo, P. Andreasson, H. Enquist, M.J. Shu, T. Pardini, M. Chollet, D. Zhu, H. Lemke, I. Ronneberger, J. Larsson, A.M. Lindenberg, H.E. Fischer, S. Hau-Riege, D.A. Reis, R. Mazzarello, M. Wuttig and K. Sokolowski-Tinten
310. Structural study of self-assembled gold mesocrystals using coherent X-ray diffraction imaging
J. Carnis, Y. Kim, R. Khubbutdinov, A. Ignatenko, E. Iashina, A. Mistonov, T. Steegemans, S. Lazarev, M. Sprung, S. Sturm, E. Sturm and I. Vartanyants
311. Energy-dispersive X-ray diffraction experiments for materials science at PETRA III
T. Wroblewski, G. Abreu Faria, C. Curfs, G. Dovzhenko, T. Lippmann, B. Schwebke, T. Dose, P. Staron and M. Müller
312. Correlations between Conductivity and AXCCA-revealed Structure in PbS-Cu₄APc Superlattices
D. Lapkin, A. Maier, N. Mukharamova, P. Frech, D. Assalauova, R. Khubbutdinov, A. Ignatenko, S. Lazarev, M. Sprung, F. Schreiber, I. Vartanyants and M. Scheele
313. Ultra-Small Angle X-ray Scattering Study of Phase Transitions in Au-PNIPAm Photonic Crystals
D. Lapkin, S. Lazarev, D. Assalauova, J. Stellhorn, F. Westermeier, M. Karg, I. Vartanyants and J.-M. Meijer
314. Reconstruction of Pt-Rh nanoparticle in Operando Reaction Condition using Bragg CXDI
Y.Y. Kim, L. Gelisio, M. Abuin, H. Runge, C. Seitz, J. Carnis, M.-I. Richard, V. Vonk, T.F. Keller, I.A. Vartanyants and A. Stierle
315. In situ experiment for selective laser melting
J. Rosigkeit, E. Maawad, P. Staron, F. Pyczak and M. Müller

Hohleiterbauteile



Rotary Joints



Rigid Bend & Twists



Special Assemblies



Flexible Waveguide Assemblies



WR650
Directional Coupler



WR650
3 to 1 Combiner

Weitere Informationen erhalten Sie über →

HEILBRONN Berliner Platz 12 • 74072 Heilbronn
Tel. (07131) 7810-0 • Fax (07131) 7810-20
HAMBURG Gutenbergring 41 • 22948 Norderstedt
Tel. (0410) 514817-0 • Fax (0410) 514817-20
MÜNCHEN Straßlacher Str. 7 • 82110 Germering
Tel. (089) 894 606-0 • Fax (089) 894 606-20

GLOBES
ELEKTRONIK

hf-welt@globes.de
www.globes.de



INSTRUMENTATION FOR OPTICAL APPLICATIONS

hRIXS Spectrometer & X-ray Diffractometer

currently under installation at SCS Beamline at European XFEL

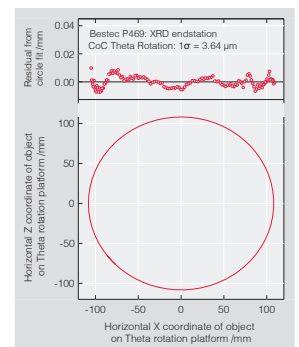
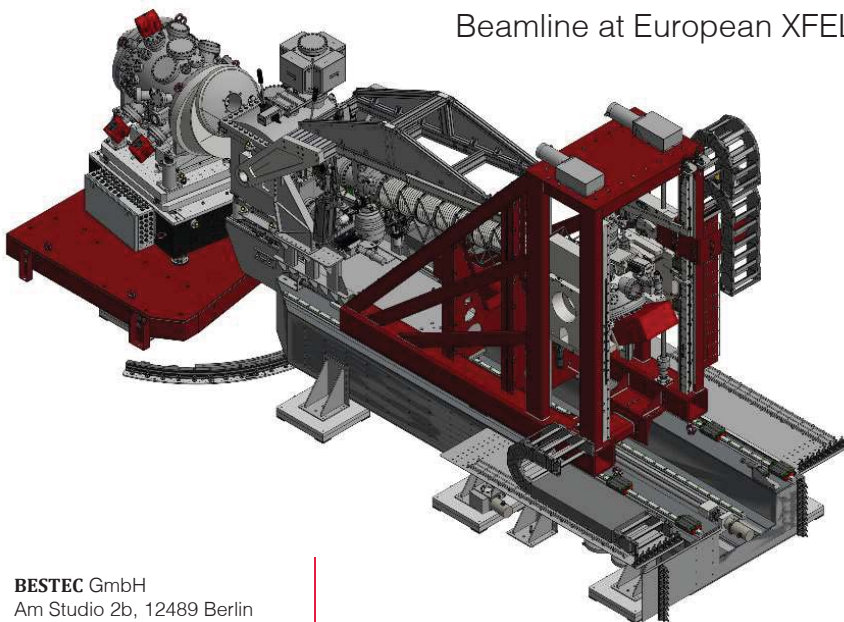

Small circle of confusion

Ultrahigh stability & repeatability

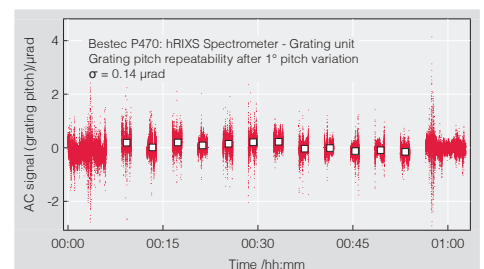

BESTEC GmbH
Am Studio 2b, 12489 Berlin
Germany
www.bestec.de
phone: +49 30 677 4376



316. Hierarchical micro-reactor as electrodes for water splitting by metal rod tipped carbon nanocapsule self-assembly in carbonized wood
X. Sheng, Y. Li, C.J. Brett, S.V. Roth, L. Berglund and L. Sun
317. Rapid crystallization of metallic glasses studied by in-situ XRD flash-annealing
J. Bednarcik, K. Kosiba, S. Pauly and A. Rothkirch
318. Luminescent properties and energy transfer processes in the single crystalline films of singly La^{3+} and Sc^{3+} and La^{3+} - Ce^{3+} and doubly Sc^{3+} - Ce^{3+} doped YAIO_3 perovskites under synchrotron radiation excitation
T. Zorenko, V. Gorbenko, T. Vozniak and Yu. Zorenko
319. Luminescent properties and energy transfer processes in singly and doubly Tb^{3+} and Eu^{3+} doped GGG film scintillators under synchrotron radiation excitation
P.-A. Douissard, T. Martin, T. Zorenko and Y. Zorenko
320. Active layer printing of hybrid solar cells with in situ GISAXS and GIWAXS
V. Körstgens, L. Diaz Piola, M. Schwartzkopf, S.V. Roth, H. Iglev, R. Kienberger and P. Müller-Buschbaum
321. Influence of anchoring ligands on magnetic properties of 3d-4f heterobimetallic complexes after deposition on a solid surface substrate
V. Mazalova, G.C. O'Neil, L. Miaja-Avila, Y. I Joe, D.S. Swetz, J.N. Ullom, K. Monakhov and P. Fromme
322. Bragg coherent X-ray diffraction imaging on single InAs nanowires
Z. Ren, T. W. Cornelius, D. Dzhigaev, F. Westermeier, M. Sprung and R. Timm
323. Luminescent properties of the crystal and single crystalline films of La^{3+} doped $\text{Lu}_3\text{Al}_5\text{O}_{12}$ scintillators under synchrotron radiation excitation
K. Bartosiewicz, A. Yoshikawa, S. Kurosawa, A. Yamaji, M. Yoshino, M. Nikl, T. Zorenko, V. Gorbenko and Y. Zorenko
324. Luminescent properties of the crystal of $\text{Lu}_{3-x}\text{Gd}_x\text{Al}_5\text{O}_{12}:\text{Ce}$ mixed garnets under synchrotron radiation excitation
T. Zorenko, S. Nizankonskiy, A. Markovskiy and Yu. Zorenko
325. μs Hydrodynamic interactions probed at the European XFEL
F. Dallari, F. Lehmkuhler, A. Jain, M. Sikorski, J. Moeller, L. Frenzel, I. Lokteva, G. Mills, M. Walther, H. Sinn, F. Schulz, M. Koof, V. Markmann, R. Bean, Y. Kim, P. Vagovic, A. Mancuso, A. Madsen and G. Grübel
326. Investigation of Europium valence state in compounds: $\text{Eu}_{1-x}^{2+}\text{Eu}_x^{3+}\text{MO}_{3+x/2}$ (M=Ti and Zr and Hf) depending on the synthesis conditions
A. Yu. Molokova, A.P. Menushenkov, V.V. Popov, E.V. Khramov, R.D. Svetogorov, V. Yu. Murzin and A.B. Kalinko
327. Qualitative phase analysis of different Mg-based-LPSO alloys using synchrotron radiation
S. Sanamar, H.-G. Brokmeier and N. Schell
328. Multiscale characterization of antique amphorae by comprehensive studies
O. Alekseeva, A. Antipin, D. Khmelenin, V. Kvartalov, A. Mandrykina, S. Monakhov and E. Tereschenko
329. High-pressure time resolved X-ray diffraction experiments of lanthanides
E.F. O'Bannon, R. Husband, M. Lipp, H.-P. Liermann, W.J. Evans and Zs. Jenei
330. Reverse bending effect on damages and substructure parameters of the binary Mg-Li alloy
V. Usov, H.-G. Brokmeier, N. Shkatulyak and O. Savchuk

331. Analysis of operando XANES spectra of Pd nanocatalysts: Big data analysis and machine learning approaches.
A.L. Bugaev, O.A. Usoltsev, A.A. Skorynina, E.G. Kamysheva, A.A. Guda, S.A. Guda and A.V. Soldatov
332. In operando resonant X-ray diffraction spectroscopy on layered Li-rich cathode materials for Li-ion batteries during cycling
C. Richter, W. Hua, D.V. Novikov, S. Indris and B. Schwarz
333. Formation and electronic structure of tetracarboxylates under extreme conditions
C. Albers, G. Spiekermann, R. Sakrowski, M. Wilke, L. Bayarjargal, C. Schmidt, L. Libon, J. Latarius, H. Gretarsson, M. Sundermann, S. Chariton, M. Tolan and C. Sternemann
334. Operando XAS study of Pt catalysts for selective oxidation of ammonia
D. Doronkin, V. Marchuk, M. Casapu and J.-D. Grunwaldt
335. Nonthermal phase transitions in metals induced by FEL irradiation
N. Medvedev and I. Milov
336. Structural evolution of Platinum polycrystalline thin films driven by ultrashort IR radiation and probed by XFEL radiation
L. Gelisio, Y.Y. Kim, S.W. Lim, D. Nam, I. Eom, M. Kim, X. Li, H. Lee, R. Khubbutdinov, S. Lazarev, S. Kim, M. Ree, C.U. Kim and I.A. Vartanyants
337. Structure Induced Device Degradation in Quantum Dot Solar Cell
W. Chen, R. Guo and P. Müller-Buschbaum
338. Constraining the kinetics of deformation at high compression rates using the dDAC on Au and Re and Pt and Fe/[Mg,Fe]O samples.
C. Plücker, R. Husband, H.-P. Liermann, H. Marquardt, A. San José Méndez, G. Morard and Z. Konôpková
339. Shear-induced ordering in liquid μ -jets revealed by X-ray cross-correlation analysis
V. Markmann, M. Koof, J. Valerio, L. Frenzel, I. Lokteva, M. Walther, G. Grübel and F. Lehmkuhler
340. Reverse bending effect on damages and substructure parameters of the binary Mg-Li alloy
V. Usov, H.-G. Brokmeier, N. Shkatulyak, O. Savchuk and N. Schell
341. 3D Active Sites of Te in Hyperdoped Si by Hard X-ray Photoelectron Kikuchi-Diffraction
M. Hoesch, M. Wang, S. Zhou, O. Fedchenko, Ch. Schlüter, K. Medjanik, S. Babenkov, A. Winkelmann, H.J. Elmers and G. Schönhense
342. MagStReXS: Magnetic Structures through Resonant X-ray Scattering
P. J. Bereciartua, S. Francoual, J. R. L. Mardegan, J. Sears, J. Rodríguez-Carvajal and F.-E. Picca
343. Resolving cavitation damage dynamics through multimodal imaging
F. Reuter, C. Deiter, R. Carley and C.-D. Ohl
344. Anisotropy and kinetics of the migration-induced layer formation in TeO₂
A. Kulikov, A. Blagov, N. Marchenkov, Yu. Pisarevsky and M. Kovalchuk
345. Postmortem analysis of Tantalum irradiated with 18 keV EuXFEL beam at 35 GPa
H. Cynn, Z. Jenei, E. O'Bannon, M.J. Lipp, R. Hrubciak, J. Smith, C. Park, N. Velisavljevic and W.J. Evans
346. Analysis of XANES spectra using machine learning algorithms
A. Guda, S. Guda, A. Martini, A. Algasov, D. Pashkov and A.V. Soldatov
347. Reaction of W with H under High Pressure and Temperature Measured by EuXFEL
V. Balandin, B. Beutner, F. Brinker, W. Decking, M. Dohlus, L. Froehlich, U. Jastrow, R. Kammering, T. Limberg, D. Noelle, M. Scholz, A. Sorokin, K. Tiedtke, M. Yurkov, I. Zagorodnov, J. Liu, L. Samoylova, U. Boesenberg, W. Freund, J. Grünert, A. Koch, N.G. Kujala, T. Maltezopoulos, M. Messerschmidt, I. Petrov, H. Sinn, J. Küpper and H.C. Team

348. In-situ investigation of orientation monopolization of Cu in Cu-GNP laminated composite during vacuum hot-pressing sintering using synchrotron dilatometer
H. Shi, Y. Zhang, W. Gan, X. Wang, A. Stark, E. Maawad, N. Schell, X. Li and C. Esling
349. Optically induced 5d magnetic dynamics in ferro- and antiferromagnetic Dysprosium
T. Amrhein, W. Bronsch, S. Jana, N. Pontius, J. Schunck, R.Y. Engel, P. Miedema, M. Beye, M. Weinelt, C. Schüssler-Langeheine and N. Thielemann-Kühn
350. Stress mapping on ultra-high strength steel cut edges.
F. Lindberg, L. Ryde, J. Brask, S.E. Hörnström, J. Östberg, F. Hansson and T. Müller
351. Residual stresses in additively manufactured aluminum alloys
M.-A. Nielsen, P. Staron, E. Maadwad, S. Bodner, J. Keckes and M. Müller
352. Ultrafast dynamics of 4f lattice coherence in the valence fluctuation compound $\text{TmSe}_{1-x}\text{Te}_x$
C.-H. Min, M. Heber, S. Müller, L. Wenthaus, S. Palutke, D. Kutnyakhov, F. Pressacco, L. Dudy, M. Silly, C. Fornari, K. Baumgärtner, H. Bentmann, W. Choi, Y. Kwon, M. Scholz, F. Reinert and K. Rossnagel
353. Application of machine learning algorithms for the analysis of the 3d metal pre-edge XANES spectra
D.M. Pashkov, S.A. Guda, A.A. Guda, A.S. Algasov, A.V. Soldatov and D.S. Rubanik
354. Analysis of $\text{Cu}_2\text{ZnSnS}_4$ thin films by 3DXRD
M. Mar Lucas, J. Wright, H.F. Poulsen and J.W. Andreasen
355. In-situ investigation of phase transformation and nitride formation in duplex steels during heating and cooling
S. Nouhi, T. Maimaitiyili, N. Pettersson, S. Wessman, L. Höglund, A. Malik, J. Y. Jonsso, A. Stark, F. Lindberg and D. Lindell
356. A fast and handy software package for large diffraction data analysis
T. Maimaitiyili, S. Nouhi, J. Brask, A. Malik and D. Lindell
357. Time-resolved X-ray diffraction studies of crystallisation process in $\text{Cu}_{47.5}\text{Zr}_{47.5}\text{Al}_5$ alloy from amorphous and liquid states
O. Shuleshova, J. Orava, X. Han, I. Soldatov, O. Gutowski, O. Ivashko, A.-C. Dippel, M. v. Zimmermann and I. Kaban
358. Time-resolved operando XANES analysis of oxidation reactions on Pd nanoparticles
A.A. Skorynina, A.L. Bugaev, O.A. Usoltsev, V. Murzin and W. Caliebe
359. Time and space resolved high energy X-ray diffraction during bonding of a γ -TiAl alloy
K. Hauschildt, A. Stark, F. Pyczak and M. Müller
360. Investigation of a catalyst based on a metal-organic framework functionalized Pd by X-ray absorption spectroscopy
E. Kamysheva, A. Skorynina, A. Lazzarini, A. Bugaev, U. Olsbye and A. Soldatov
361. Amorphization and crystallization of Pd-Si films via ultrashort pulsed laser irradiations
J. Antonowicz, P. Zalden, K. Sokolowski-Tinten, K. Georganakis, R. Minikayev, F. Bertram, A.L. Greer, J. Varias, O. Magnussen, M. Chojnacki, P. Kuźmiuk, K. Fronc, D. Klinger, M. Kozłowski, M. Kłomski, K. Ławniczak-Jabłońska and R. Sobierajski
362. Ultrafast synchrotron X-ray imaging reveals the dynamics interaction between in van der Waals layered materials and ultrasonic bubble in the liquid
L. Qin
363. Towards ultrafast dynamics in spin-filter material Europium oxide with RIXS at FLASH
S. Dziarzhyski, M.Z. Sohail, R.Y. Engel, J.O. Schunck, P.S. Miedema, G. Brenner, M. Sinha, S. Chizbaian and M. Beye

364. Exploring magnetic materials at beamline P09 at PETRA III
J. Mardegan, S. Francoual, J. Strempler, L. Bouchenoire, C. Dettlefs, M. Tolkiehn, T. Spitzbart, O. Leopold and H.-C. Wille
365. Planet formation experiment: Microtomography on the experimental outcomes
D. Spahr, T.E. Koch, D. Merges, A.A. Beck, J.M. Carlsson, O. Christ, S. Fujita, P.-T. Genzel, J. Kersch, M. Lindner, D. Mederos-Leber, F. Wilde, W. Morgenroth, V. Milman, F.E. Brenker and B. Winkler
366. Quick Spectroscopic Operando Imaging of Partial oxidation of Methane
S. Alizadehfanaloo, A. Schropp, T. Sheppard, M. Seyrich, V. Murzin, J. Becher, J. Garrevoet, J.-D. Grunwaldt and C. Schroer
367. ZnO and the influence of strain on the piezotronic effect visualized with insitu X-ray (coherent) nano diffraction
P. Jordt, S. Hrkac, N. Wolff, J. Warias, A. Sartori, C. Krywka, L. Kienle, O. Magnussen and B. Murphy
368. Hard X-ray spectroscopy of magnetic materials
A. Gloskovskii, G.H. Fecher and W. Drube
369. Interaction of carbonates with the Fe-containing peridotite at the upper mantle conditions
N. Martirosyan
370. CaCO₃ phase diagram at high pressure and effect of cationic substitution on the phase behavior
N. Martirosyan
371. First Measurements Using the Pulsed Magnetic Setup at the MID Instrument
K. Kazarian, I. Lobato, K. Sukharnikov, C. Youngman, R. Schaffer, A. Zozulya, U. Boesenberg, J. Hallmann, C. Kim, W. Lu, J. Moeller, M. Reiser, M. Scholz, R. Shayduk and A. Madsen
372. Optical Spectroscopy of Diamond Anvil Cells at Free Electron Lasers
O.B. Ball and R.S. McWilliams
373. Two Flavors of Superconductivity in YBa₂Cu₃O_{6.67}
J. Choi, O. Ivashko, E. Blackburn, R. Liang, D.A. Bonn, W.N. Hardy, A.T. Holmes, N.B. Christensen, M. Hücker, S. Gerber, O. Gutowski, U. Rütt, M. v. Zimmermann, E.M. Forgan, S.M. Hayden and J. Chang
374. Exploration of depth-dependent properties of CrAl(Si)N coatings
J. Latarius, D. Stangier, J. Forov, O. Gutowski, D. Grisales Pareja, M. Paulus, W. Tillmann and M. Tolan
375. X-ray spectroscopy of supercooled water droplets
C. Goy, Z. Yin, A. Schottelius, A. Kalinin, F. Trinter, P. Miedema, J. Valerio, P. Busse, J. Möller, F. Lehmkuhler, A. Jain, J. Viehhaus, M. Beye, G. Grübel, S. Techert and R.E. Grisenti
376. Time-resolved investigation of the liquid-to-solid phase transition in supercooled atomic liquids
A. Schottelius, J. Möller, F. Lehmkuhler, L. Gelisio, R. Kurta, I. Vartaniants, G. Grübel, A. Madsen and R. Grisenti
377. Two-dimensional energy and carrier diffusion in silicon upon X-ray irradiation or swift heavy ion impact
V. Lipp and B. Ziaja
378. Towards Understanding the Kinetics of Fast Compression in the dynamic-DAC
R. Husband, Z. Jenei, E. O'Bannon, W. Evans and H.-P. Liermann
379. Convergent beam crystallography with Multilayer Laue lenses
N. Ivanov, L. Chufeng, S. Bajt and H. Chapman
380. Synthesis in-situ characterisation and crystal structure of a copper(II) oxalate oxamide dioxime complex: Toward the development of new anticancer drug
P. Djonwouo, G. Doungmo, J. Ströh, J. Nenwa, P. Lönnecke and H. Terraschke

III.7 Nano science

381. In-situ monitoring of the crystallization Eu^{3+} and Sm^{3+} doped CaWO_4 by luminescence and synchrotron-based X-ray diffraction analysis
P. Djonwouo, A. C. Weigt, J. Ströh, G. Doungmo and H. Terraschke
382. Ultrafast Demagnetization Excited by Extreme Ultraviolet Light From a Free-Electron Laser
A. Philippi-Kobs, L. Müller, M. H. Berntsen, W. Roseker, M. Riepp, K. Bagschik, J. Wagner, R. Frömter, M. Danailov, F. Capotondi, E. Pedersoli, M. Manfredda, M. Kiskinova, M. Stransky, V. Lipp, A. Scherz, B. Ziaja, H. P. Oepen and G. Grübel
383. Probing the growth of nanocrystals at the liquid-liquid interface using high energy X-ray diffraction
A. Sarma, A.-C. Dippel, M. K. Sanyal, O. Gutowski, T. F. Keller and M. von Zimmermann
384. In situ self-assembly of nanocrystals studied by SAXS and XCCA
I. Lokteva, M. Koof, M. Walther, G. Grübel and F. Lehmkuhler
385. Cryo X-ray Absorption Spectroscopy of Copper Zinc Tin Sulfide Nanoparticles
C. Rein, T. Ramos and J. W. Andreasen
386. Protein biosensor based on nanowire FET
T. Smolyarova
387. High resolution mapping of X-ray beam induced current from nanowire devices
L. Chayanun, J. Soltau, M. Osterhoff, T. Salditt, G. Otnes, M.T. Borgstrom and J. Wallentin
388. Following the crystallization of Ag nanoparticles by *in-situ* powder diffraction and absorption spectroscopy
J. Santos Avelar, J. Ströh, L. Ruiz Arana, P. L. Djonwouo, M. Etter and H. Terraschke
389. Spatially-resolved luminescence and crystal structure of single core-shell nanowires measured in the as-grown geometry
A. Al Hassan, J. Lähnemann, S. Leake, H. Küpers, M. Niehle, D. Bahrami, F. Bertram, R.B. Lewis, A. Davtyan, T.U. Schüllli, A. Trampert, L. Geelhaar and U. Pietsch
390. X-ray microdiffraction analysis of WS_2 nanotubes: TEM comparison study
A. Khadiev, D. Novikov and J. Raabe
391. Magnetic sample characterization at the DESY Nanolab
L. Bocklage, C. Strohm and R. Röhlberger
392. Structural analysis of Au-Cu nanoparticles under electrochemical control via Coherent Diffraction Imaging
L. Marçal, A. Björling, G. Carbone, J. Gullón and J. Wallentin
393. Probing carrier collection at 10 nm resolution using XBIC & MZP
J. Soltau, L. Chayanun, J. Wallentin and M. Osterhoff
394. Structure of complex fluids under shear flows
J. Valerio, F. Lehmkuhler, T. Kalff, D. Sheyfer, M. Walther, L. Frenzel, A. Jain, J. Lal, M. Sprung and G. Grübel
395. Charge transport properties of mesoporous $\text{La}_{1-x}\text{Sr}_x\text{MnO}_3$ thin-films
K. Klauke, H. Noei, A. Stierle and S. Mascotto
396. Applying Oblique-Incidence Deposition to Tailor Magnetic Properties of CoFeB in Single Thin Films and TMR Stacks.
S. Willing, K. Schlage, T. Gurieva, M. Ramin Moayed, L. Bocklage and R. Röhlberger
397. Probing the colloidal stability and formation of protein corona of inorganic nanoparticles in complex biological environments
F. Otto, F. Westermeier, C. Sanchez-Cano, N. Feliu and W.J. Parak

398. Shear-induced structure formation in colloidal systems
M. Koof, F. Dallari, I. Lokteva, V. Markmann, E. Stellamanns, F. Lehmkuhler and G. Grübel
399. Cluster-mining: An approach for determining core structures of nanoparticles from atomic pair distribution function (PDF) data
S. Banerjee, C. Liu, K. Jensen, P. Juhas, J. Lee, M. Tofanelli, C. Ackerson, C. Murray and S. Billinge
400. Femtosecond Single-Particle Diffractive Imaging of 3D DNA-Origami Nanostructures using XFEL Pulses
P.L. Xavier, O. Yefanov, K. Ayyer, L. Gelisio, W. Brehm, T. Witte, F. Trost, J. Bielecki, A. Samanta, A. Estillore, L. Worbs, J. Luebke, S. Awel, N. Roth, K. Beyerlein, R. Kirian, D. Horke, J. Knoska, Z. Meznar, R. Sha, M. Azubel, D. Bushnell, A. Barty, S. Bajt, R.D. Kornberg, J. Kuepper, N.C. Seeman and H.N. Chapman

III.8 Collaboration Poster

- Wayforlight: the catalogue of European light
- Lightsources.org
- LEAPS
- KFS - Komitee Forschung mit Synchrotronstrahlung
- NFFA

ONE VOICE FOR THE BRIGHTEST SCIENCE

lightsources.org

lightsources.org is the result of a collaboration between communicators from light source facilities around the world.

A worldwide voice for the light source user community



24 organisations

Representing 29 facilities worldwide, 22 synchrotrons and 7 FELs



40,000 articles

Published by our user community between 2013 and 2017



6,300 protein structures

Deposited by our user community into the worldwide Protein Data Bank in 2018

SIGN UP TO OUR WEEKLY NEWSLETTER!

-  www.lightsources.org
-  [@lightsources](https://twitter.com/lightsources)
-  [lightsources.org](https://www.linkedin.com/company/lightsources.org)
-  [lightsources_org](https://www.instagram.com/lightsources_org)

WWW.LIGHTSOURCES.ORG

A single platform for:

- News and science highlights
- Proposal deadlines
- Career opportunities, PhD and postdoc positions
- Workshop and conference calendars
- Profile page for each facility

IV Author Index (Submitting author only)

(Submitting author and poster number)

AKKURATOV,Valentin	47	CHEN,Wei	337
ALBERS,Christian	333	CHOI,Jaewon	373
ALEKSEEVA,Olga	328	CHUMAKOV,Andrei	279
ALFELD,Matthias	35	CIEŚLIK,Iwona	301
ALIZADEHFANALOO,Saba	366	COLAIZZI,Lorenzo	116
ALLUM,Felix	190	COLOMBO,Alessandro	93
ALVES FRANÇA,Bruno	233	CONCEIÇÃO,Andre	25
ANDALEEB,Hina	226	CYNN,HYUNCHAE	345
ANNA,Ivanova	230	DALLARI,Francesco	325
ANTONOVA,Angelina	239	DANILEWSKY,Andreas	60
ANTONOWICZ,Jerzy	361	DESCAMPS,Adrien	43
APPI,Elisa	112	DIEKMANN,Florian	181
ARISTOV,Victor	268	DIGUROV,Roman	274
ARMEEV,Grigoriy	231	DIPPEL,Ann-Christin	114
ASSALAUOVA,Dameli	210	DJONWOUO,Patrick Lionel	380, 381
BALL,Orianna	372	DÖRING,Florian	42
BALLA,Prannay	28	DÖRNER,Simon	186
BANERJEE,Soham	399	DORONKIN,Dmitry	334
BARANOVA,Iuliia	215	DOSE,Thomas	22
BARTNIK,Andrzej	162	DREIMANN,Matthias	37
BARTOSIEWICZ,Karol	323	DUCHNA,Monika	302
BAULIN,Roman	283	DZIARZHYTSKI,Siarhei	65
BAUM,Markus	299	ECKERMANN,Dennis	56
BAUMANN,Thomas	164	ECKERMANN,Marina	203
BAXTER,James	257	ENGEL,Robin Y.	127
BEDNARCIK,Jozef	317	ENGLISCH,Uwe	78
BEKX,John Jasper	166	ESMAEILDOOST,Niloofar	251
BERECIARTUA,Pablo J.	342	EXNER,Christian	241
BERTRAM,Florian	10	FALCH,Ken Vidar	113
BIEDNOV,Mykola	11	FALKE,Sven	240
BINCK,Jannes	156	FALKENBERG,Gerald	9
BISWAS,Naireeta	205	FARLA,Robert	2
BOBKOV,Sergey	84	FERREIRA RAMOS,Ana Sofia	246
BOCKLAGE,Lars	391	FIEDLER,Stefan	244
BOGER,Juliane	252	FRANCOUAL,Sonia	17
BORNMANN,Benjamin	126	FROHN,Jasper	204
BRASK,Johannes	350	GAAL,Peter	53
BRETT,Calvin	266	GARIDEL,Patrick	200
BRUNS,Hendrik	219	GAUS,Lennart	179
BUCHHORN,Michael	137	GAWLITZA,Peter	130
BUCK,Jens	287	GAWNE,Thomas	180
BÜSCHER,Julia	55	GELISIO,Luca	336
BUGAEV,Aram	331	GENSCH,Marc	269
BUHR,Ticia	150	GIOVANNETTI,Gaia	185
BUKREEVA,Inna	224	GIRI,Rajendra Prasad	29
BURCHERT,Jan-Philipp	36	GOY,Claudia	16, 375
CALIEBE,Wolfgang	3	GRAEFENSTEIN,Andreas	227
CARLEY,Robert	285	GRECO,Alessandro	102
CARNIS,Jerome	310	GRÜNERT,Jan	99
CASSINI,Chiara	214	GUDA,Alexander	346
CHAYANUN,Lert	387	GUDA,Sergey	171

GURIEVA, Tatiana	262	KREBS, Dietrich	92
HAAS, Sylvio	7	KUJALA, Naresh	96
HAIDL, Andreas	88	KULIKOV, Anton	344
HAKANPÄÄ, Johanna	232	KUTNYAKHOV, Dmytro	121
HAUSCHILDT, Katja	359	LAKNER, Pirmin	282
HE, Lanhai	170	LAPKIN, Dmitry	312, 313
HEBER, Michael	284	LATARIUS, Jan	374
HEILRATH, Andrea	159	LE GUYADER, Loïc	118
HEJRAL, Uta	193	LEHMKÜHLER, Felix	296, 297
HEYM, Johannes	218	LETRUN, Romain	101
HLOSKOVSKY, Andrei	368	LIENERT, Ulrich	13
HOEPPE, Hannes Paul	255	LIERMANN, Hanns-Peter	20, 21
HOESCH, Moritz	71, 341	LIESKE, Julia	216, 217
HÖVELMANN, Svenja	250	LIPP, Vladimir	377
HOFMANN, Luisa	33	LIU, Goksin	212
HUMPHRIES, Oliver	168	LIU, Jia	122
HUSBAND, Rachel	378	LÖMKER, Patrick	289
HUSTON, Larissa	77	LOHSE, Leon Merten	115
IGNATENKO, Alexandr	39	LOKTEVA, Irina	384
IKONNIKOVA, Kseniia	209	LONGO, Elena	128
IVANOV, Nikolay	379	LOVATO, Clémentine	208
IVANOV, Rosen	74	MAIMAITIYILI, Tuerdi	355, 356
IVASHKO, Oleh	105	MAKAL, Anna	148, 149
JAIN, Avni	303, 304	MALTEZOPOULOS, Theophilos	46
JAIN, Megha	300	MAR LUCAS, Mariana	354
JEPSEN, Lars	73	MARDEGAN, Jose	364
JO, Wonhyuk	90	MARIANI, Valerio	206
JORDT, Philipp	367	MARKMANN, Verena	339
JUHA, Libor	196	MARKOVSKYI, Anton	324
JUREK, Zoltan	176	MARTIROSYAN, Naira	369, 370
JURGILAITIS, Andrius	41	MARÇAL, Lucas	392
KADEK, Alan	247	MASCOTTO, Simone	395
KÄRCHER, Victor	45	MAZALOVA, Victoria	207, 321
KAMIŃSKI, Michał	26	MAZZA, Tommaso	178
KAMYSHOVA, Elizaveta	360	MCBRIDE, Emma	154
KARNBACH, Oliver	145	MEDINA, Cristian	160
KARPETS, Maksym	306	MEDVEDEV, Nikita	335
KAZARIAN, Karina	371	MEDVEDEV, Pavel	27
KELLER, Thomas	5	MERCADIER, Laurent	109
KERBSTADT, Stefanie	167	MERCURIO, Giuseppe	12
KHADIEV, Azat	390	METJE, Jan	52
KHARITONOV, Konstantin	72	MILOV, Igor	272
KHUBBUTDINOV, Ruslan	40	MIN, Chul Hee	352
KIKHNEY, Ai	229	MOLODENSKIY, Dima	237
KIM, Jaeyong	347	MOLODTSOVA, Maria	136
KIM, Young Yong	314	MOLODTSOVA, Olga	267
KIMBER, Simon	143	MOLOKOVA, Anastasia	326
KLUMPP, Stephan	4	MOORE, James	80, 81
KNESCHAUREK, Ekaterina	277	MORIACHKOV, Roman	199
KNOSKA, Juraj	139	MORON, Marc	201
KOCH, Andreas	23	MUDRICH, Marcel	141, 142
KÖRSTGENS, Volker	320	MÜLLER-BUSCHBAUM, Peter	270
KOLATZKI, Katharina	147	MUKHARAMOVA, Nastasia	158
KOOF, Michael	398	MURRAY, Kevin	24
KOTLOV, Aleksei	18	NÉMETH, Zoltán	131
KRASILNIKOV, Mikhail	103	NEUHAUS, Charlotte	245

NIEHAVES, Claudia	61	SANAMAR, Soheil	327
NIELSEN, Marc-André	351	SARASWATHULA, Krishna Chaitanya	183
NIERHAUVE, Alena	278	SARMA, ABHISAKH	383
NISSEN, Matz	276	SARTORI, Andrea	261
NOVIKOV, Dmitri	8	SAVCHUK, Olena	330
O'BANNON, Earl	329	SCHÄFER, Julia M.	191
OBERTHUER, Dominik	236	SCHAEPER, Jannis Justus	213
ONVLEE, Jolijn	175	SCHEU, Max	281
OSOLODKIN, Dmitry	238	SCHIRMEL, Nora	135
OSSIG, Christina	91	SCHLAPPA, Justine	64
OSTERHOFF, Markus	30, 31	SCHLUETER, Christoph	19
OTTO, Ferdinand	397	SCHOEKEL, Alexander	293
OTZEN, Christoph	108	SCHÖNHERR, Robert	248
PASHKOV, Danil	353	SCHÖPS, Andreas	94
PASSOW, Christopher	86	SCHOLZ, Markus	273
PENA, Gisel	138	SCHOTTELIUS, Alexander	376
PENNICARD, David	70	SCHROER, Martin	49
PERRY-SASSMANNSHAUSEN, Alexander	140	SCHROPP, Andreas	132
PETROV, Ilia	50, 51	SCHUBERT, Kaja	174
PETROVA, Olga	223	SCHULZ, Joachim	6
PHILIPPI-KOBS, André	382	SCHUNCK, Jan	271
PICCHIOTTI, Alessandra	188	SCHWARZ, Julius	187
PIETSCH, Ullrich	389	SCHWINZER, Martin	228
PLATUNOV, Mikhail	305	SEARS, Jennifer	69
PLÜCKTHUN, Christian	338	SEECK, Oliver	1
POLIKARPOV, Maxim	221	SELIKHANOV, Georgii	225
POSTOLNYI, Bogdan	15, 286	SEYRICH, Martin	75
PRESCHER, Clemens	107	SHAITAN (SHAYTAN), Konstantin	222
PRESTER, Andreas	243	SHEN, Chen	291
QIN, Ling	362	SHENG, Xia	316
QIU, Canrong	265	SHESTAKOV, Mikhail	295
RAHMANN, Hendrik	211	SHI, Hailong	348
RAMIN MOAYED, Mehdi	83	SHI, YuanFeng	161
RANDOLPH, Lisa	153	SHNEYDMILLER, Evgeny	44
REICHARDT, Marius	202	SHULESHOVA, Olga	357
REIN, Christian	385	SKORYNINA, Alina	358
REINWARDT, Simon	194	SLYAMOV, Azat	129
REISER, Mario	234	SMEKHOVA, Alevtina	76
REN, zhe	322	SMOLYAROVA, Tatyana	386
REUTER, Fabian	343	SOBIERAJSKI, Ryszard	292
RICHTER, Carsten	332	SOHAIL, Muhammad Zain	363
RILEY, David	79	SOLTAU, Jakob	393
RIVAS, Daniel	119, 184	SPAHR, Dominik	365
RODRIGUEZ-FERNANDEZ, Angel	68	SPIEKERMANN, Georg	110
RÖRING, Aljoscha	177	STAŃCZYK, Wiktoria	198
ROMANYUK, Oleksandr	260	STACHNIK, Karolina	125
ROSIGKEIT, Jan	315	STAROSTIN, Vladimir	100
ROTH, Friedrich	263, 264	STEINBRÜGGE, René	165
ROUND, Adam	32	STIEGLITZ, Hergen	308
ROUND, Ekaterina	253	STOCKHAUSEN, Kilian	235
RÜTER, Tonn	95	STRÖH, Jonas	388
RUIZ LOPEZ, Mabel	62	SUKHARNIKOV, Vladislav	151
RYSOV, Rustam	63	SZAMOTA-LEANDERSSON, Karolina	59
SACCHI, Maurizio	294	TARASOV, Ivan	307
SADASHIVAIAH, Sakshath	133, 288	THIELEMANN-KÜHN, Nele	87, 349
SALMAN, Sarper	111	THIESS, Sebastian	89

TIMMERMANN, Sonja	54	WARIAS, Jonas	259
TOBER, Steffen	290	WENTHAUS, Lukas	82
TROST, Fabian	195	WESTERMEIER, Fabian	14
TRUNK, Ulrich	34	WIEMANN, Carsten	120
TSAKOV, Ivan	197	WILDE, Fabian	98
TYRALA, Krzysztof	146	WILLING, Svenja	396
ULLAH, Najeeb	242	WIND, Nils	134
UNGER, Isaak	163	WITTMEIER, Andrew	220
USOV, Valentin	340	WITTWER, Felix	58
VAGIN, Pavel	104	WOJTASZEK, Klaudia	298
VAKILI, Mohammad	57	WORBS, Lena	182
VALERIANOVNA, Oxana	256	WROBLEWSKI, Thomas	311
VALERIO, Joana	394	XAVIER, P Lourdu	400
VANKÓ, György	192	YANG, Long	189
VASSHOLZ, Malte	123, 249	YAROSLAVTSEV, Alexander	124
VELARDE, Pedro	144	YEFANOV, Oleksandr	258
VELTEN, Sven	280	YU, Qiqi	152
VESTER, Peter	48, 155	YURKOV, Mikhail	66, 67
VOIGT, Katja	106	ZAK, Emil	169
VOLKOV, Sergey	275	ZALDEN, Peter	309
VOLOTKA, Andrey	172, 173	ZOLOTAREV, Sergei	85
VON STETTEN, David	254	ZORENKO, Yuriy	318, 319
VOZDA, Vojtech	117	ZOZULYA, Alexey	97
WACHULAK, Przemyslaw	38		
WAGNER, Tobias	157		



Technology of the world most intense THz source at affordable prices

Tera-Bullet

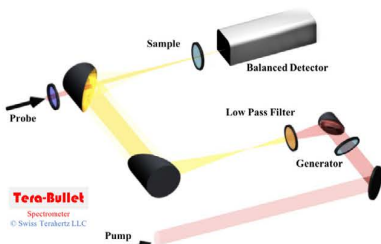

- Intense THz spectrometer for nonlinear spectroscopy and electron acceleration
- Starting from 9k Eur

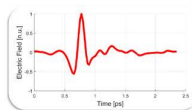
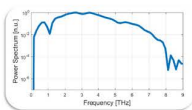

RIGI uncooled micro-bolometer



- Ultra-compact and broadband
- Sold with 1 year warranty
- Pixel Size (down to 15 μm)
- Active Area (> 29 x 16 mm)
- Array size (> 1M Pixel)
- Starting from 2.8 Eur

Extremely sensitive: NEP/pixel < 1.5 pW/√Hz

- Frequency: 4,6 THz
- Power: 0.6 μW
- Integration time: 50 μs
- Acquisition: Single shot

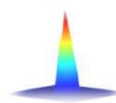

DAST/DSTMS/OH1/BNA organic crystals

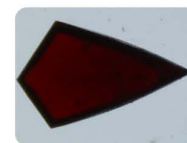

- Operate at Ti:Sa, OPA, OPCPA and 1 μm lasers
- Most efficient and affordable organic emitters
- Sold with 2 years warranty
- Up to 83 MV/cm THz fields (world record)
- Starting from 1k Eur

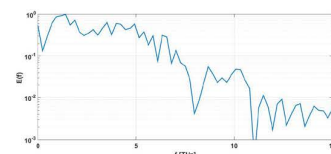

BNA +
1050nm
pump

1% efficiency

EXHIBITOR	Standnr.
ADL Analoge & Digitale Leistungselektronik GmbH	K29
Aerotech GmbH	21
Agilent Technologies Sales & Services GmbH & Co. K	30
ALCA TECHNOLOGY SRL	K 22
Allectra GmbH	16
Amplitude Laser Group	K 3
attocube systems AG	38
AXILON AG	K 1
Beckhoff Automation GmbH & Co. KG	37
Berthold Technologies GmbH & Co. KG	11
BESTEC GmbH	18
Carl Zeiss SMT GmbH	33
Class 5 Photonics GmbH	K11
Cryoandmore Budzylek GbR	K24
Cryophysics GmbH	40
CryoVac GmbH & Co KG	K 9
Cycle GmbH	K15
DECTRIS Ltd.	K 27
EKSMA Optics	7
el-spec GmbH	13
Excillum AB	12
Feinmechanik Ulrich Klein GmbH	K 5
FMB	K 35
GLOBES Elektronik GmbH & CO KG	17
Goodfellow GmbH	27
greateyes GmbH	43
Hamamatsu Photonics Deutschland GmbH	8
HENKEL Beiz-und Elektropolier-technik GmbH Co. KG	10
Hitachi High Technologies America Ltd	K 12
HORIBA Jobin Yvon GmbH	K7
Hositrad Vacuum Technology	28
Huber Diffractionstechnik / AXO	1
Hy-Lok D Vertriebs GmbH	26
Incienta Technologie GmbH & PREVAC sp. z o.o.	2
incoatec GmbH	35
Johann Fischer Aschaffenburg Präzisionswerk	K 31
Just Vacuum GmbH	K19
Kashiyama Europe GmbH	4

Kleindiek Nanotechnik GmbH	K 33
Kurt J. Lesker Company	K23
LAB motion systems	K 2
Laser 2000 GmbH	K 36
Leybold GmbH	34
Linear- und Handhabungstechnik GmbH & Co. KG	6
LIOP-TEC GMBH	20
MDC Vacuum	K16
mechOnics ag	31
MEWASA AG	K14
Micro TCA	K 30
Newport Spectra-Physics GmbH	45
nVent - SCHROFF GmbH	22
OELZE Präzisions-Messzeugfabrik GmbH	K 21
OPTOMAN	K13
Pfeiffer Vacuum GmbH	32
Physik Instrumente (PI) GmbH & Co. KG	14
Phytron GmbH	19
PINK GmbH Vakuumtechnik	3
qutools GmbH	29
REUTER TECHNOLOGIE GmbH	23
Rigaku Europe SE	K 6
SmarAct GmbH	42
SPECS Surface Nano Analysis GmbH	K 4
Spetec GmbH	K 34
Standa UAB	15
Steinmeyer Mechatronik GmbH	K17
STOE & CIE GmbH	K 32
Swagelok Hamburg / BEST Fluidsysteme GmbH	36
swiss	K20
Sydor Technologies	K25
TECUUM AG	44
Teledyne LeCroy GmbH	24
TWINNUT GmbH	K10
VACGEN Ltd	5
Vacuum FAB srl	39
vakuumfinder.de	41
vaqtec-scientific	K 28
VAT Deutschland GmbH	25
Xenocs	K 26
X-Spectrum GmbH	K 18



CONNECT AND PROTECT

Comprehensive cooling solutions

FOR TEST & MEASUREMENT PURPOSES AND DEPLOYMENT IN BIG SCIENCE APPLICATIONS

- The infrastructure to keep your electronics up and running
- Air or water cooled cabinets for optimized temperature control
- Managed air cooling inside MircoTCA.4 or AdvancedTCA Crates

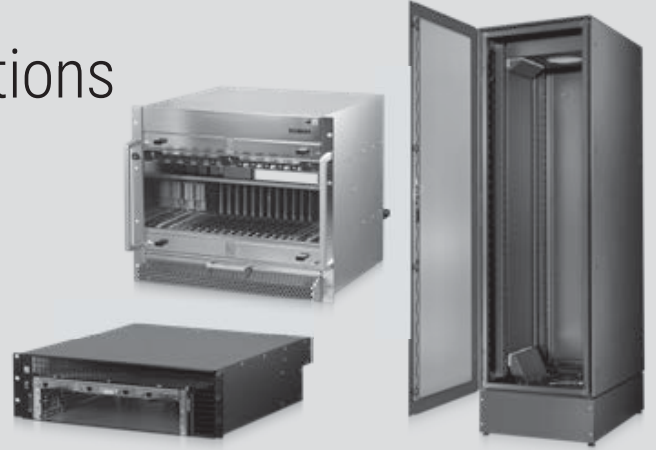

Comprehensive cooling solutions
@ nVent.com/SCHROFF

Our powerful portfolio of brands:

CADDY ERICO HOFFMAN RAYCHEM SCHROFF TRACER

nvent

SCHROFF

Industry Exhibition and Poster Session

Location: Kuppel and Dome Hamburg Luruper
Chaussee 30 – see Campus Map

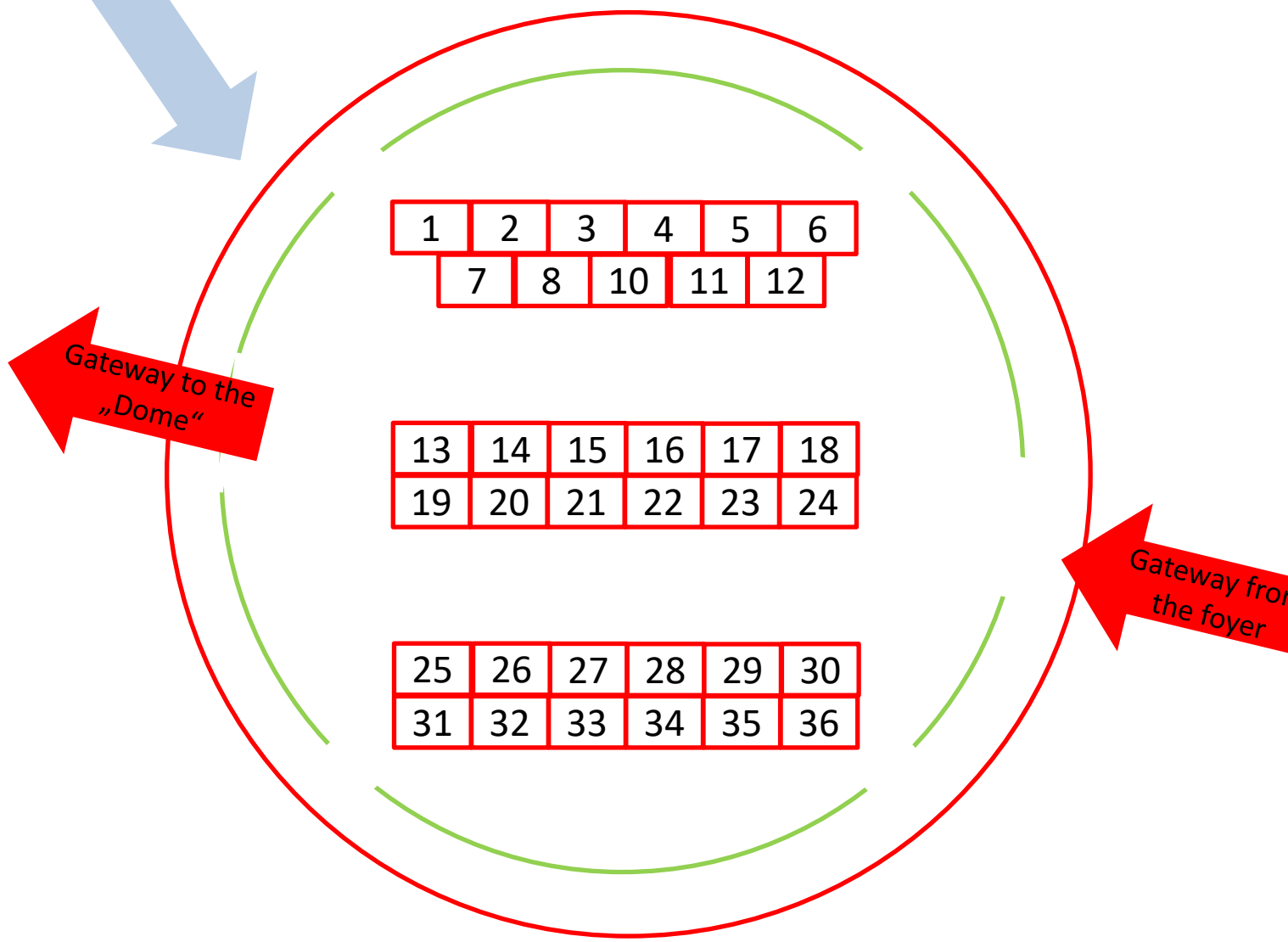
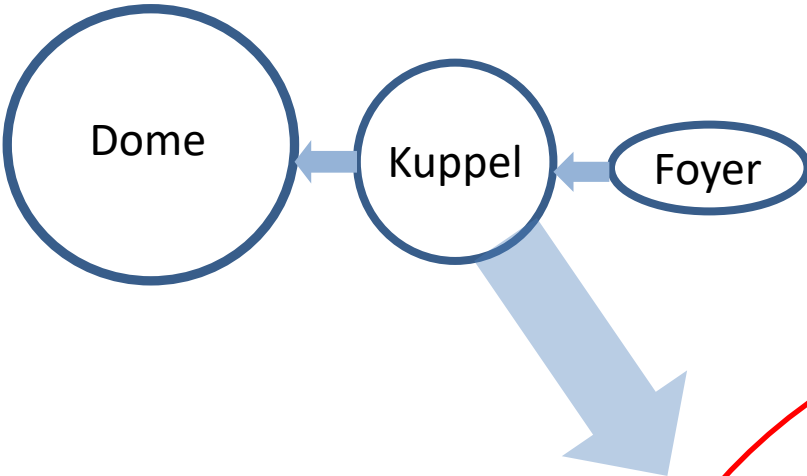

1	2	3	4	5	6
7	8	10	11	12	

13	14	15	16	17	18
19	20	21	22	23	24

25	26	27	28	29	30
31	32	33	34	35	36

Industry Exhibition and Poster Session

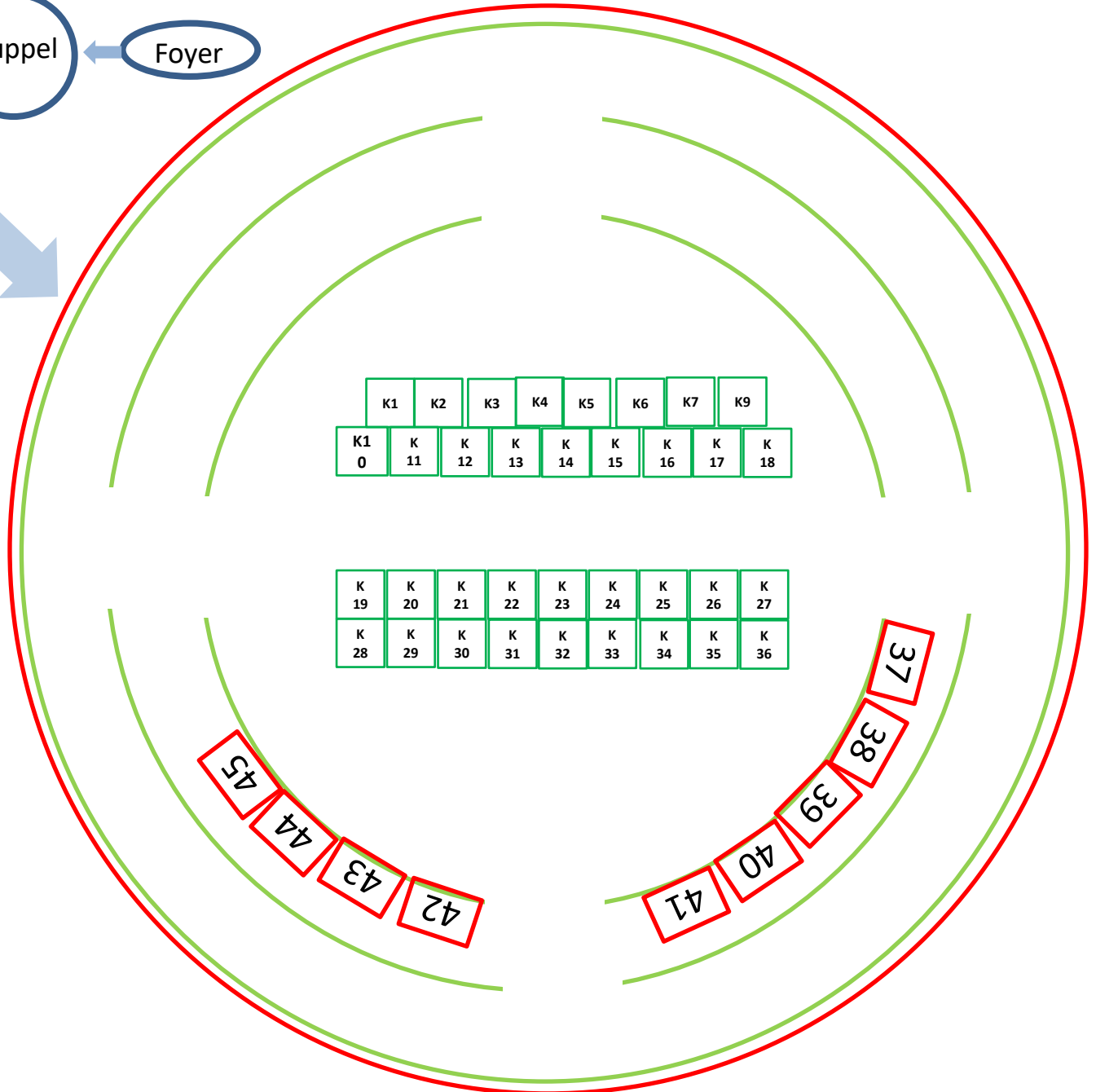
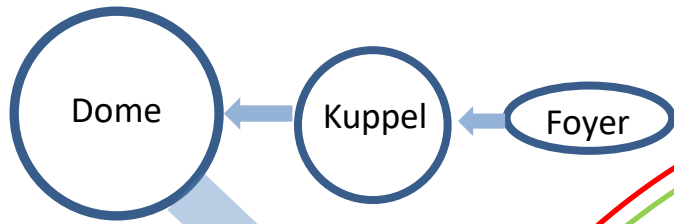

K1	K2	K3	K4	K5	K6	K7	K9	
K10	K11	K12	K13	K14	K15	K16	K17	K18

K19	K20	K21	K22	K23	K24	K25	K26	K27
K28	K29	K30	K31	K32	K33	K34	K35	K36

45	44	43	42
----	----	----	----

37	38	39	40	41
----	----	----	----	----

DESY-Campus Hamburg-Bahrenfeld

Poster session/Vendor exhibition
(Kuppel Hamburg)

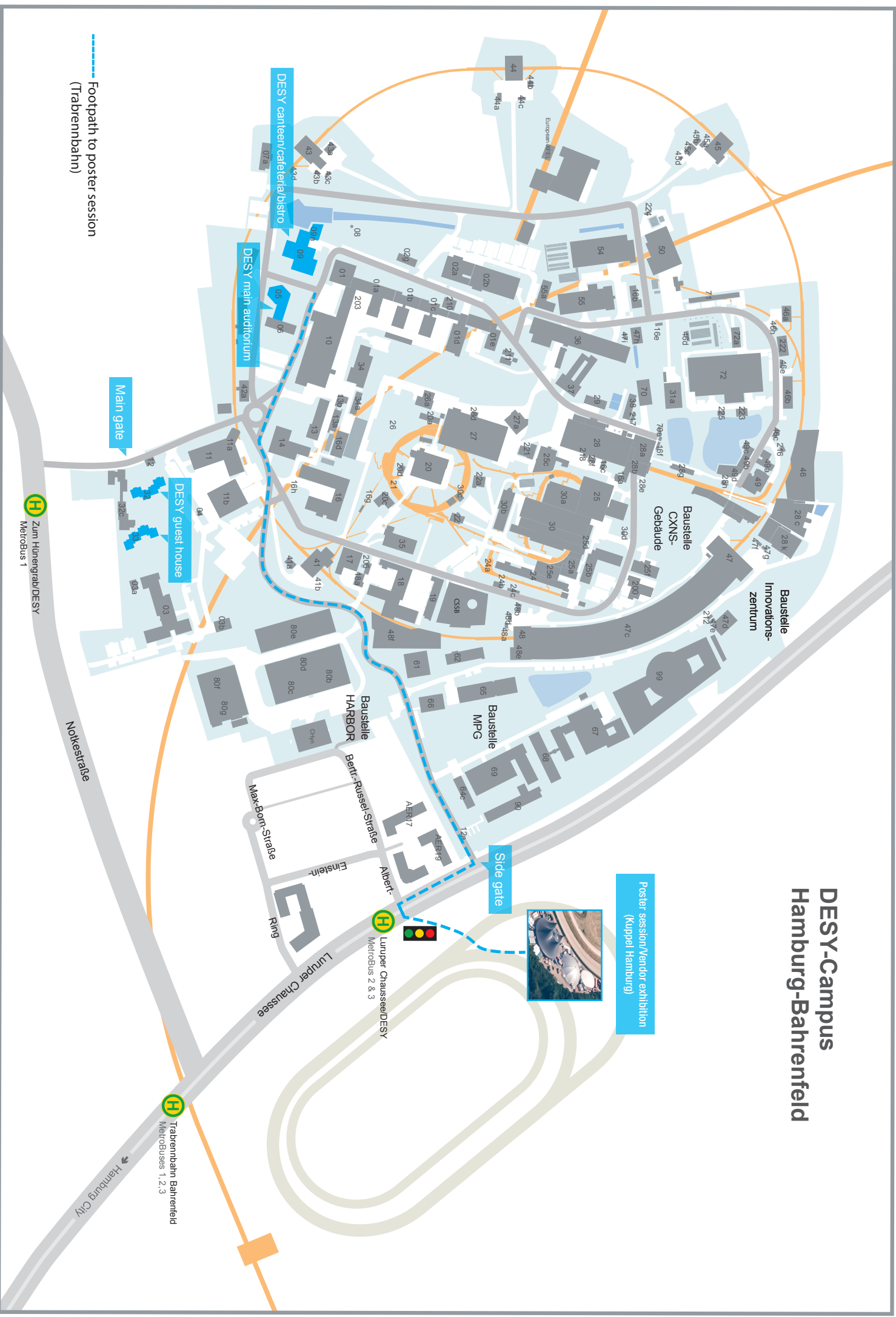

Footpath to poster session
(Trabrennbahn)

Zum Hünengrab/DESY
Metrobus 1

Lurper Chaussee/DESY
Metrobus 2 & 3

Trabrennbahn Bahrenfeld
Metrobuses 1, 2, 3

Hamburg City