

HIE-ISOLDE R&D project

M. Pasini

CERN and K. U. Leuven

Including 3 supplementary slides on the layout of the test cryostat

Courtesy O. Capatina

The ISOLDE facility

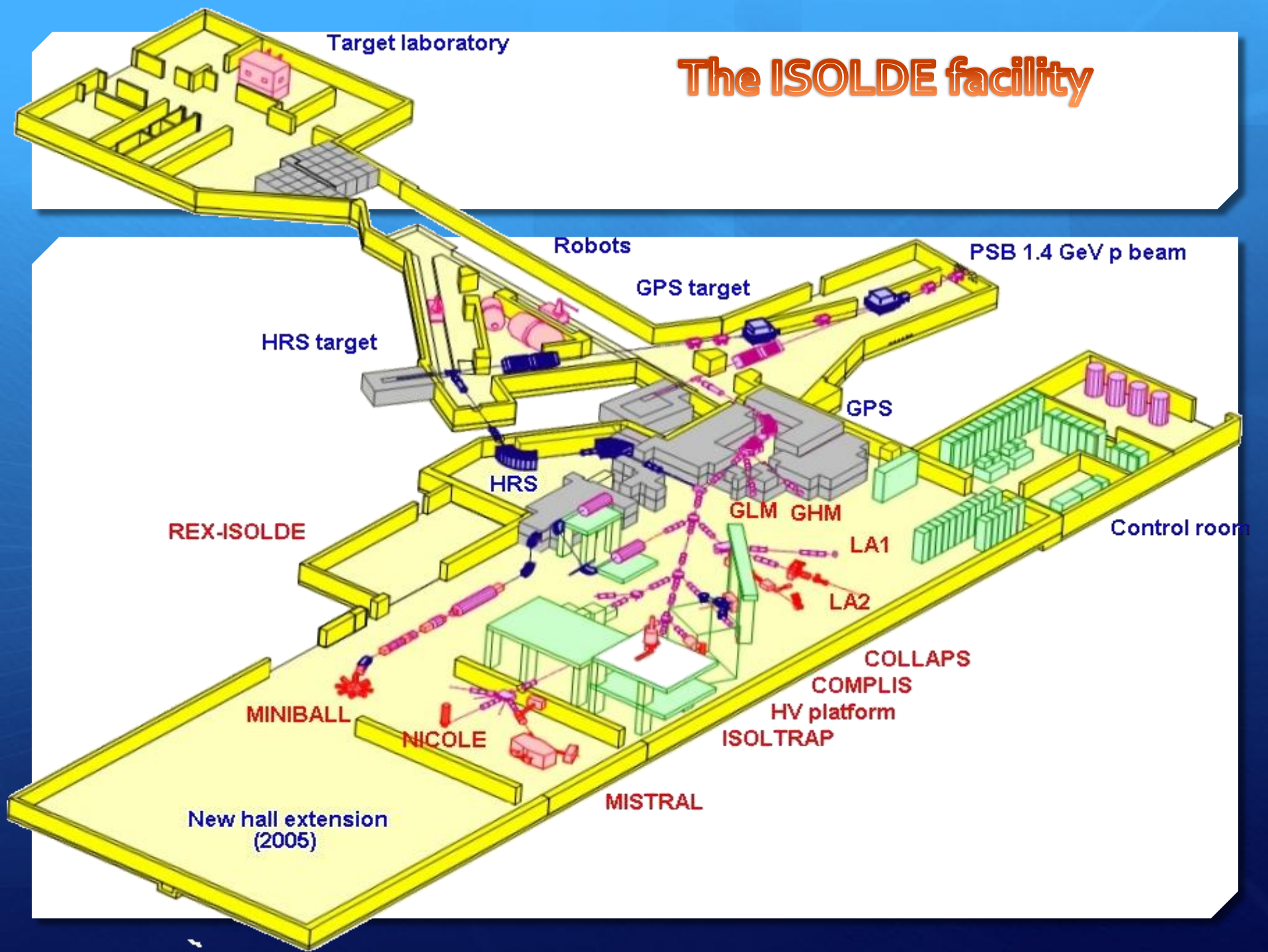

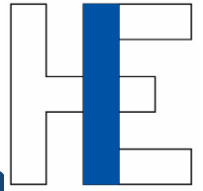

HIE-ISOLDE project description (1/2)

- + The HIE-ISOLDE project concentrates on the construction of the SC LINAC and associated infrastructure in order to upgrade the energy of the post-accelerated radioactive ion beams to **5.5 MeV/u in 2013** and **10 MeV/u by 2014/2015**
- + **The design study** for the intensity upgrade, also part of HIE-ISOLDE, **starts in 2011/2012**, and addresses the technical feasibility and cost estimate for operating the facility at **10 kW** once LINAC₄ and PS Booster are online. **The 30 kW option (SPL beam) will be studied at a later stage**

SC-linac for the HIE-ISOLDE project

- + SC-linac between 1.2 and 10 MeV/u (energies below 1.2 MeV are achievable but the machine is not optimized)
- + 32 SC QWR (20 @ $\beta_0=10.3\%$ and 12 @ $\beta_0=6.3\%$)
- + Energy fully variable; energy spread and bunch length are tunable.
- + $2.5 < A/q < 4.5$ limited by the room temperature cavity
- + 16.02 m length (without matching section)
- + New beam transfer line to the experimental stations

QWR cavities (Nb sputtered)

Low β



High β

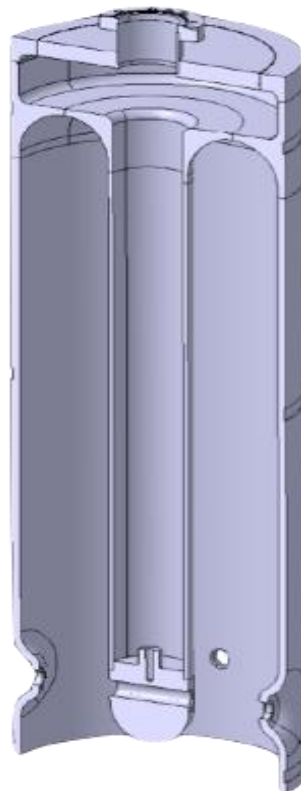
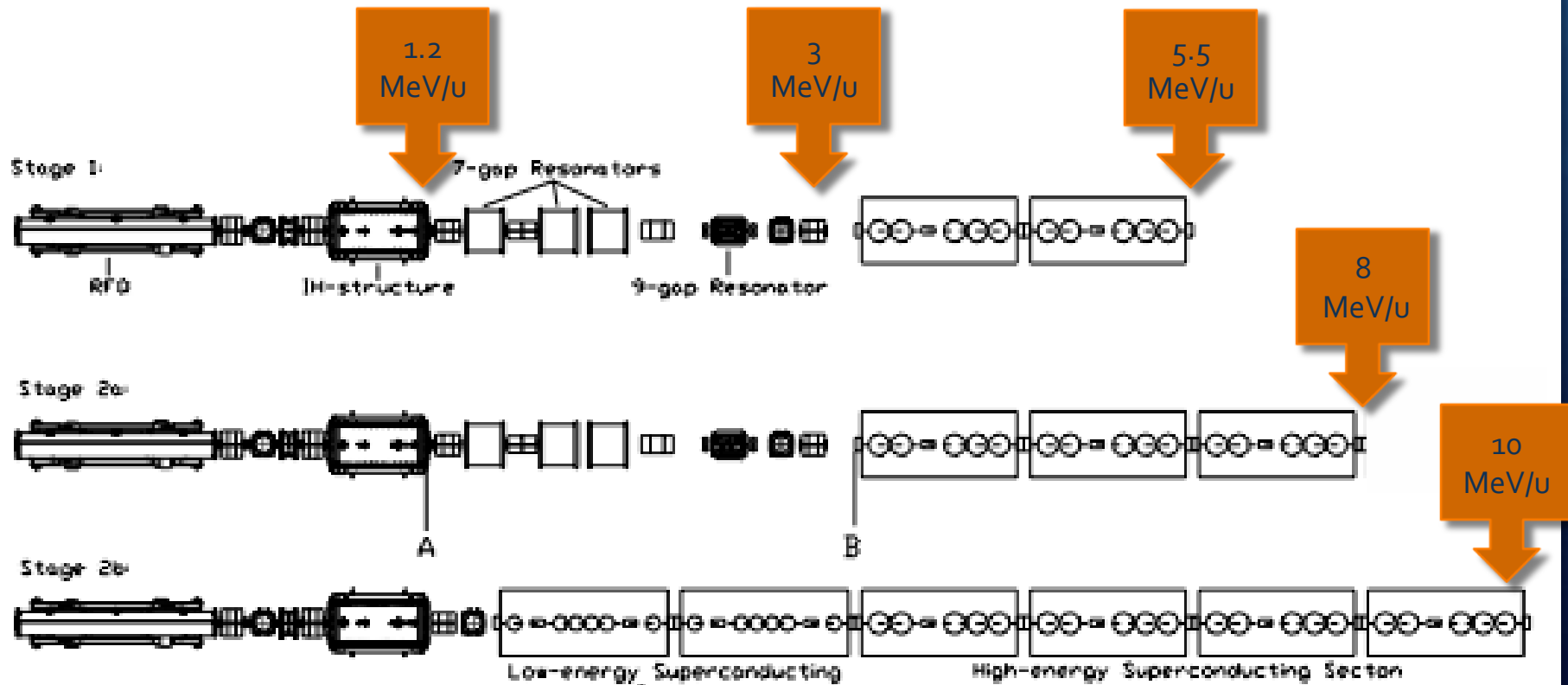

Table 1: Cavity design parameters

Cavity	Low β	high β
No. of Cells	2	2
f (MHz)	101.28	101.28
β_0 (%)	6.3	10.3
Design gradient E_{acc} (MV/m)	6	6
Active length (mm)	195	300
Inner conductor diameter (mm)	50	90
Mechanical length (mm)	215	320
Gap length (mm)	50	85
Beam aperture diameter (mm)	20	20
U/E_{acc}^2 (mJ/(MV/m) ²)	73	207
E_{pk}/E_{acc}	5.4	5.6
H_{pk}/E_{acc} (Oe/MV/m)	80	100.7
R_{sh}/Q (Ω)	564	548
$\Gamma = R_s \cdot Q_0$ (Ω)	23	30.6
Q_0 for 6MV/m at 7W	$3.2 \cdot 10^8$	$5 \cdot 10^8$
TTF max	0.85	0.9
No. of cavities	12	20

HIE-ISOLDE LINAC - layout

3 stages installation



Cu Substrate Mechanical design criteria

- + Avoid any brazing or annealing:
 - + Negative experience from LNL for coating performance
 - + Loss of mechanical properties
- + Cu-OFE C10100 cold worked (rolled sheets, forged billets).
- + Choice of manufacturing 100% at CERN workshop, thus using only available techniques:
 - + Long distance EB welding possible
 - + Inner EB welding not possible
 - + Deep drawing and now full 3D machining for beam ports.

Cavity copper substrate



THPPO010

From Bias to Magnetron sputtering

DE

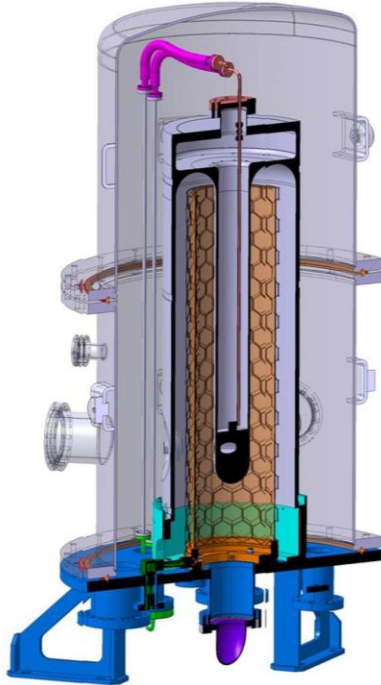

Bias Diode Sputtering:

Outcomes:

- Unstable plasma: after 20-40 min the plasma disappeared from the outer part of the cathode. Non homogeneous distribution of the plasma.

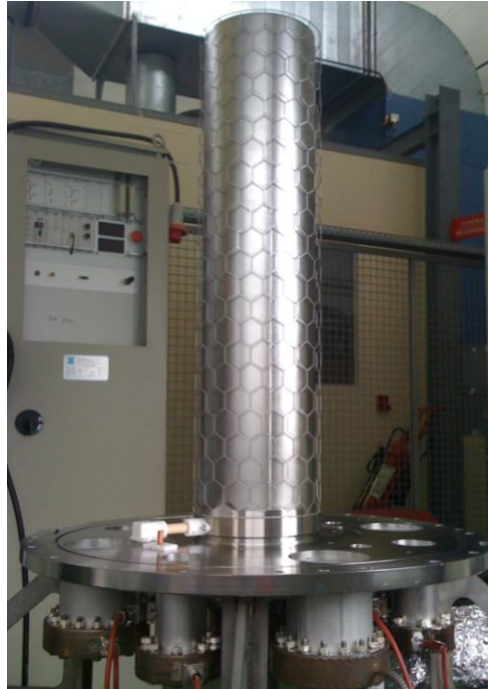

Magnetron Sputtering:

Outcomes:

- Stable plasma
- Improvements on the thickness
- More homogeneous distribution of the plasma between outside and inside



Cavity successfully sputtered

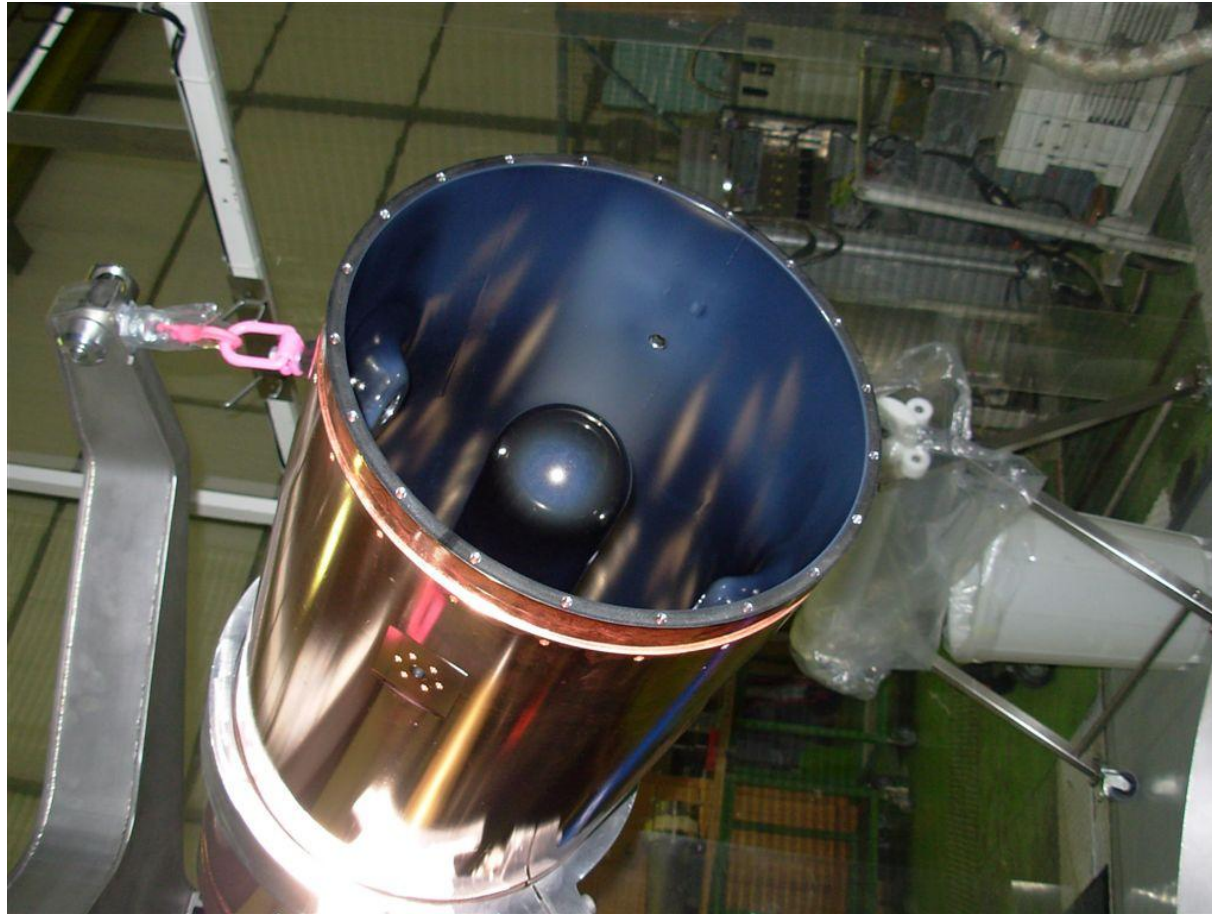

High β cryomodule

Features:

- ❑ Single vacuum cryostat
- ❑ Side loading of the cold masses
- ❑ Independent alignment of the cavities w.r.t. solenoid
- ❑ Heat shield cooled by He cold gas

COUPLER

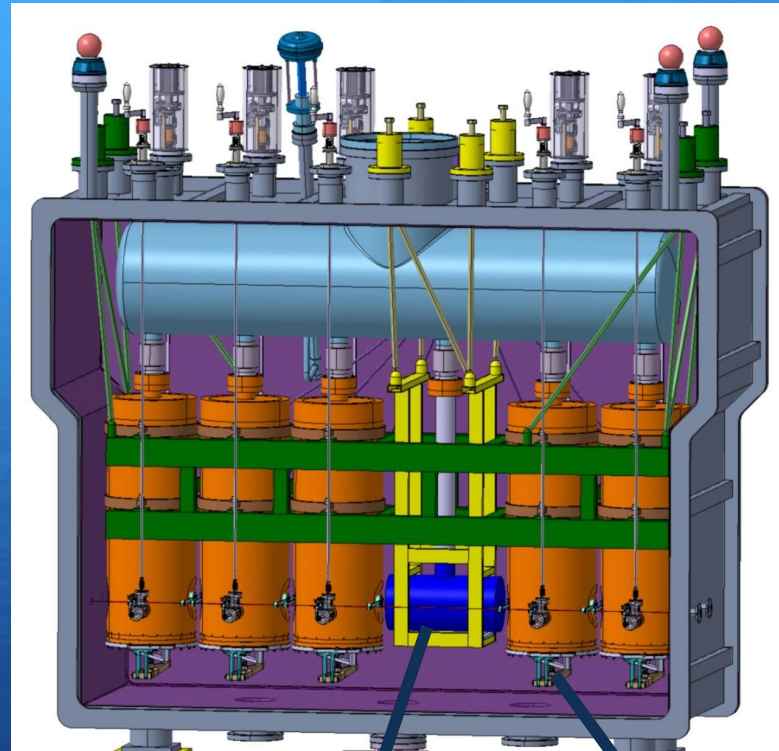
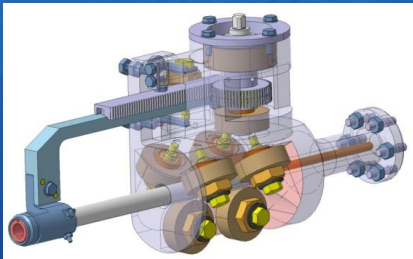

MOTORISATION
DRIVE
TUNER

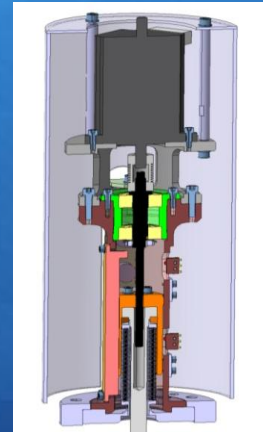

TUNER RF



PROTOTYPE
SOLENOID
Nb3Sn

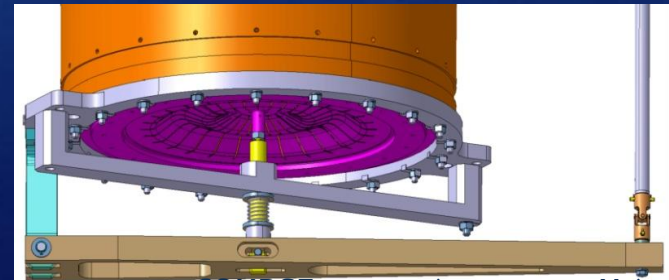

COURSE= 20mm (pour 20000 Hz)

Layout of cryostat insert

courtesy O. Capatina, T. Renaglia



Overview

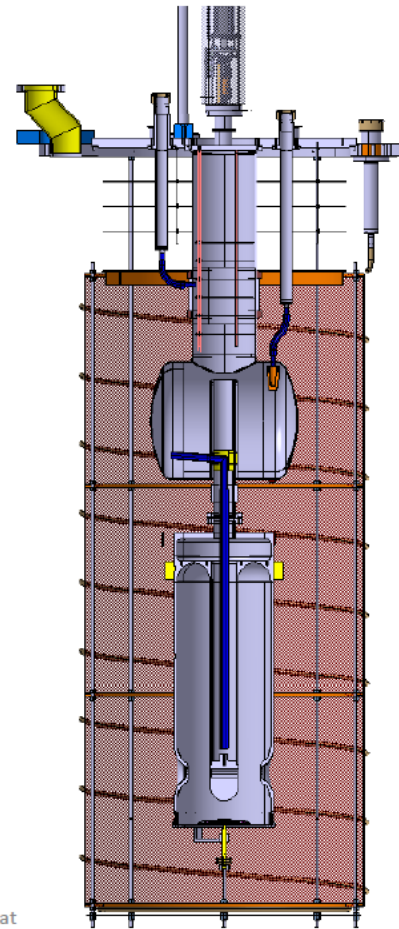
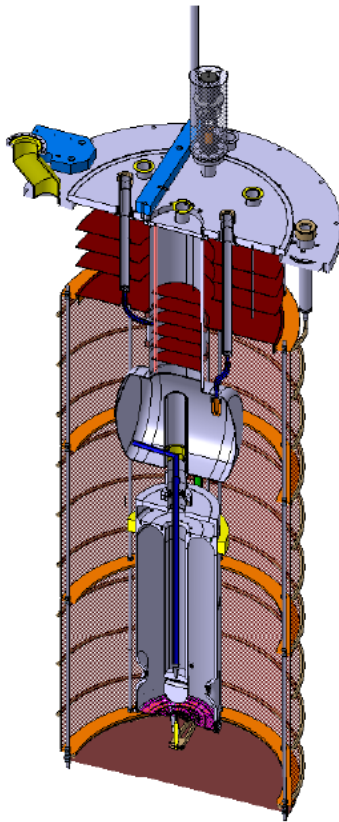

30/Nov/2009,
OC, TR, EN/MME

SRF meeting - HIE Isolde test cryostat

Thermosyphon principle



Thermosyphon used for CMS

- Several studies done for the 4 Tesla superconducting solenoid CMS:
 - Two-phase natural circulation loops commonly called thermosyphons - are thermofluid-dynamic systems mainly used to refrigerate a heat source by means of the buoyancy driven motion of a fluid in a loop, instead of mechanical pumping =>

They are able to generate larger circulation rates than single-phase loops and therefore capable of larger heat transfer rates. In view of this, thermosyphons have large industrial applications in energy plants as nuclear reactor, electrical machines and superconducting magnets.

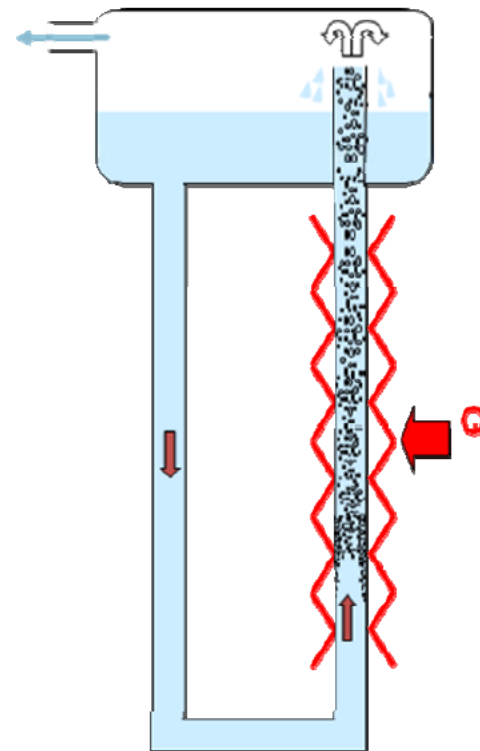

Thermosyphon for test cryostat

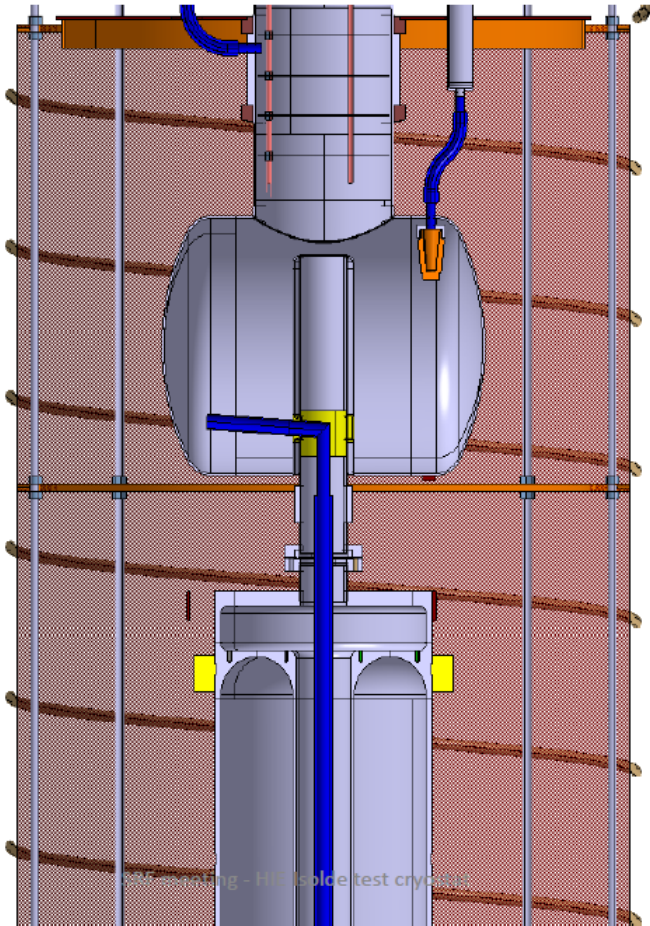

© 2015 by Intel - High Power test cryostat

In our case

- The steady state estimated total (gas + liquid) massflow 30 g/s
- Represents $v_{liq\ alim} = 0.5\ m/s$
- Pressure drop $alim < 0.2\ mbar$

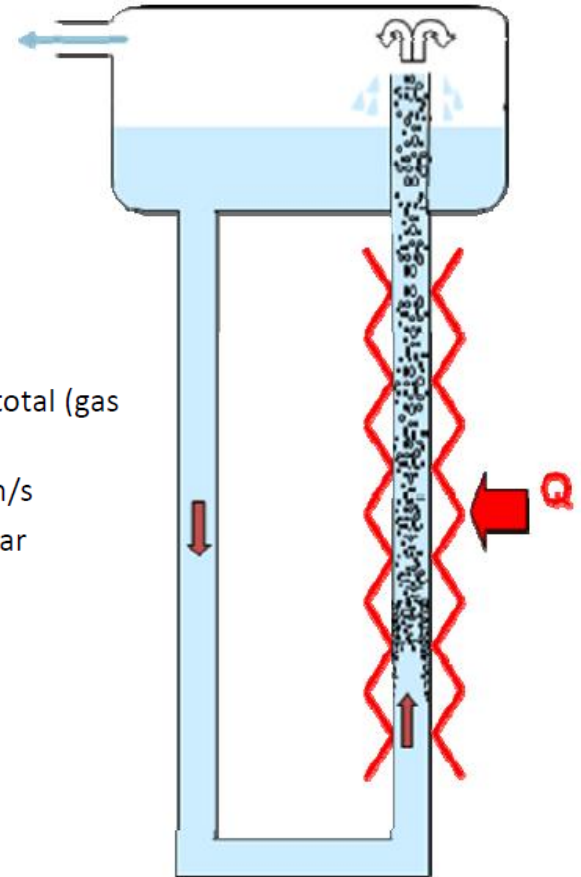

R&D summary

- + The sputtering of the first cavity prototype is done, RF cold test are ongoing
- + Concept study of the high beta cryomodule is complete. Detailed study has started.
- + A new test stand for QWR cavity testing is under construction at CERN. We expect to start first measurement in June 2010.
- + All cavity subsystems (coupler, tuner, driving motors and controls) are in fabrication.

Hot news from today (e-mail)

+ First $Q(E)$ measurements done at TRIUMF (Vancouver)

