

# First Online Reinforcement Learning on Hardware at a Particle Accelerator

Luca Scomparin, Michele Caselle, Andrea Santamaria Garcia, Chenran Xu, Edmund Blomley, Johannes L. Steinmann, Erik Bründermann, Andreas Kopmann, Marc Weber, Anke-Susanne Müller

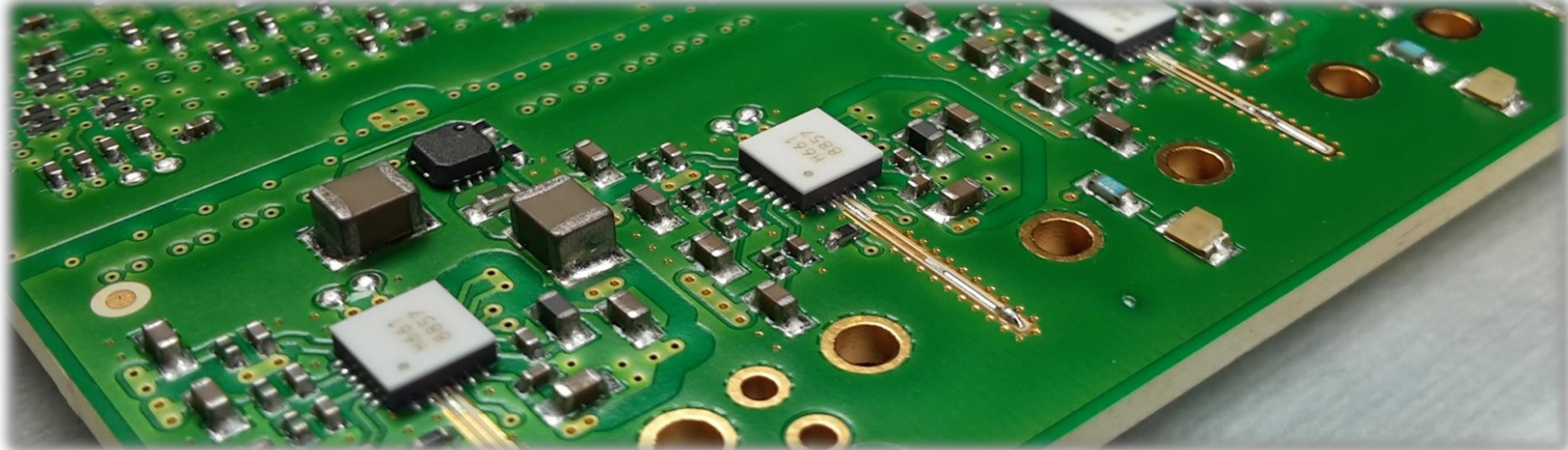

# Damping Horizontal Betatron oscillations

Challenge: damp betatron oscillations induced by kicker @ KARA by acting on stripline kicker

Impossible with conventional hardware due to latency and throughput

Using of KINGFISHER platform running on novel Xilinx Versal

Damping improves with experience, the system is learning!

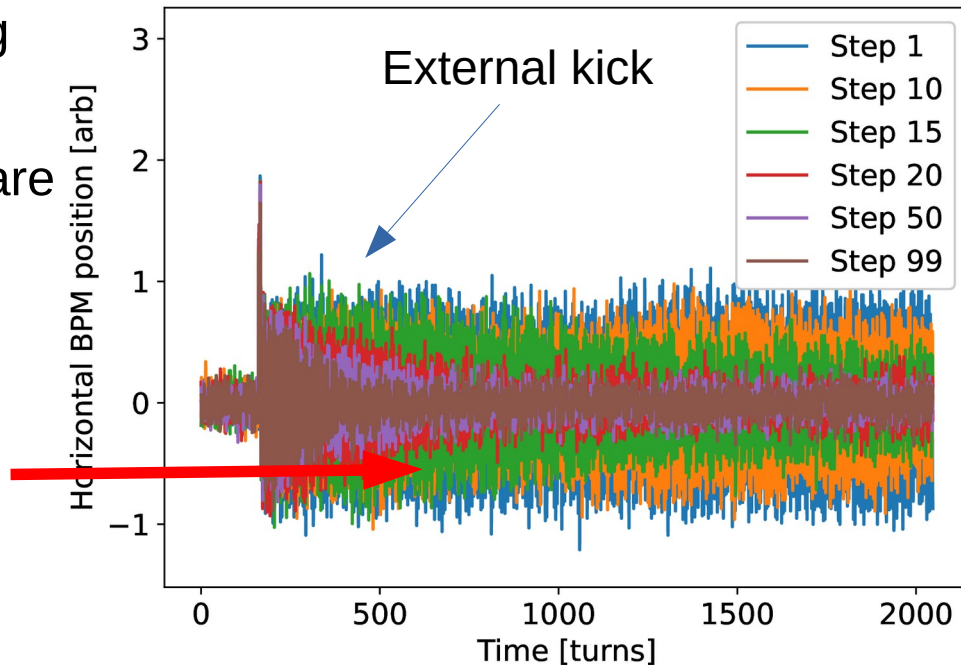

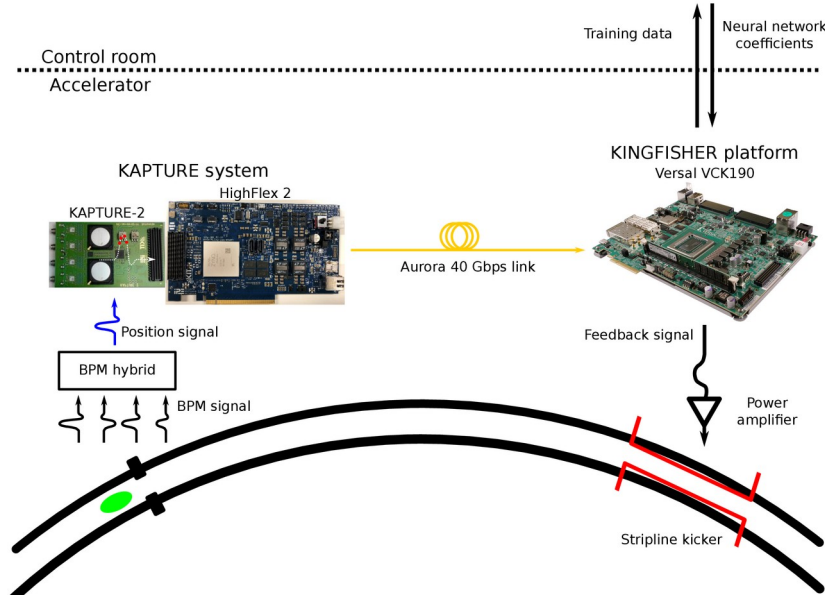

Computer by symbolic from Noun Project

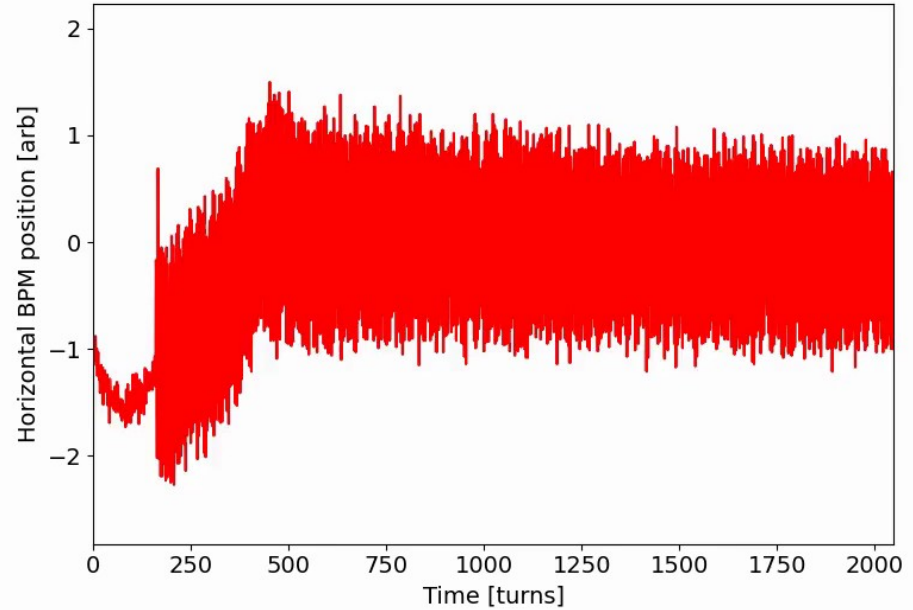

# See you at the poster!