



HAMBURG · ZEUTHEN

DESY

Tier 2 and NAF

Peter Wegner, Birgit Lewendel
for DESY-IT/DV

Tier 2: Status and News

NAF: Status, Plans and Questions

DESY



Basics T2:



HAMBURG · ZEUTHEN

- **1.5 average Tier 2 are requested by CMS-groups for Germany**
- **Desy commitment: 1 av. Tier 2 for CMS**
- - “ - **1 av. Tier 2 for Atlas**
- - “ - **1 av. Tier 2 for LHCb**
- **Aachen commitment: 0.5 average Tier 2**
- **Desy's Tier 2 is distributed between Hamburg and Zeuthen**

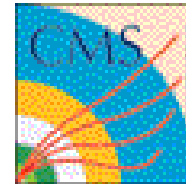

DESY



The Tier 2 is part of larger Grid@DESY



HAMBURG · ZEUTHEN

Managed via Virtual Organisations (VOs)

see: grid.desy.de

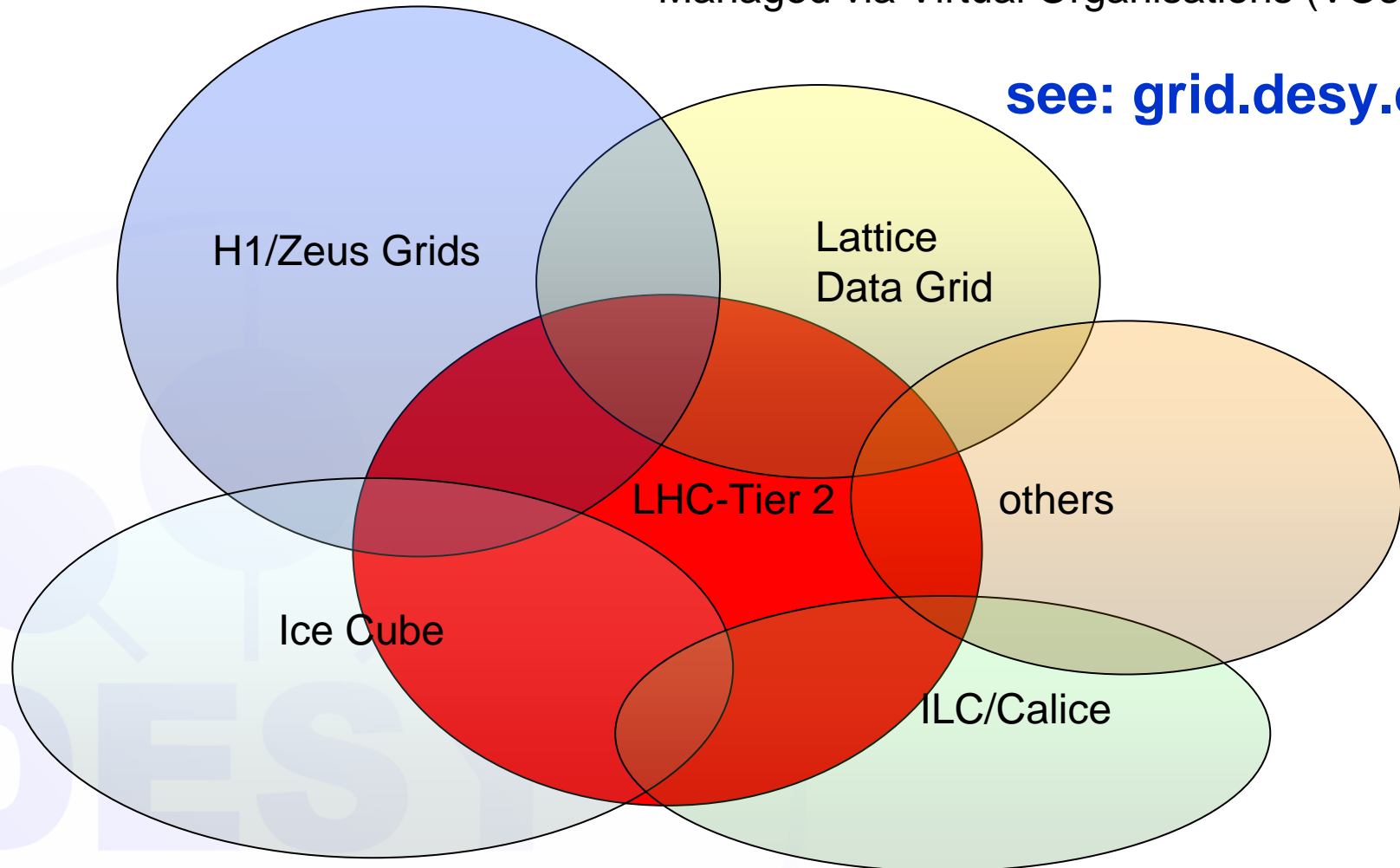

Grid Infrastructure and T2



HAMBURG · ZEUTHEN

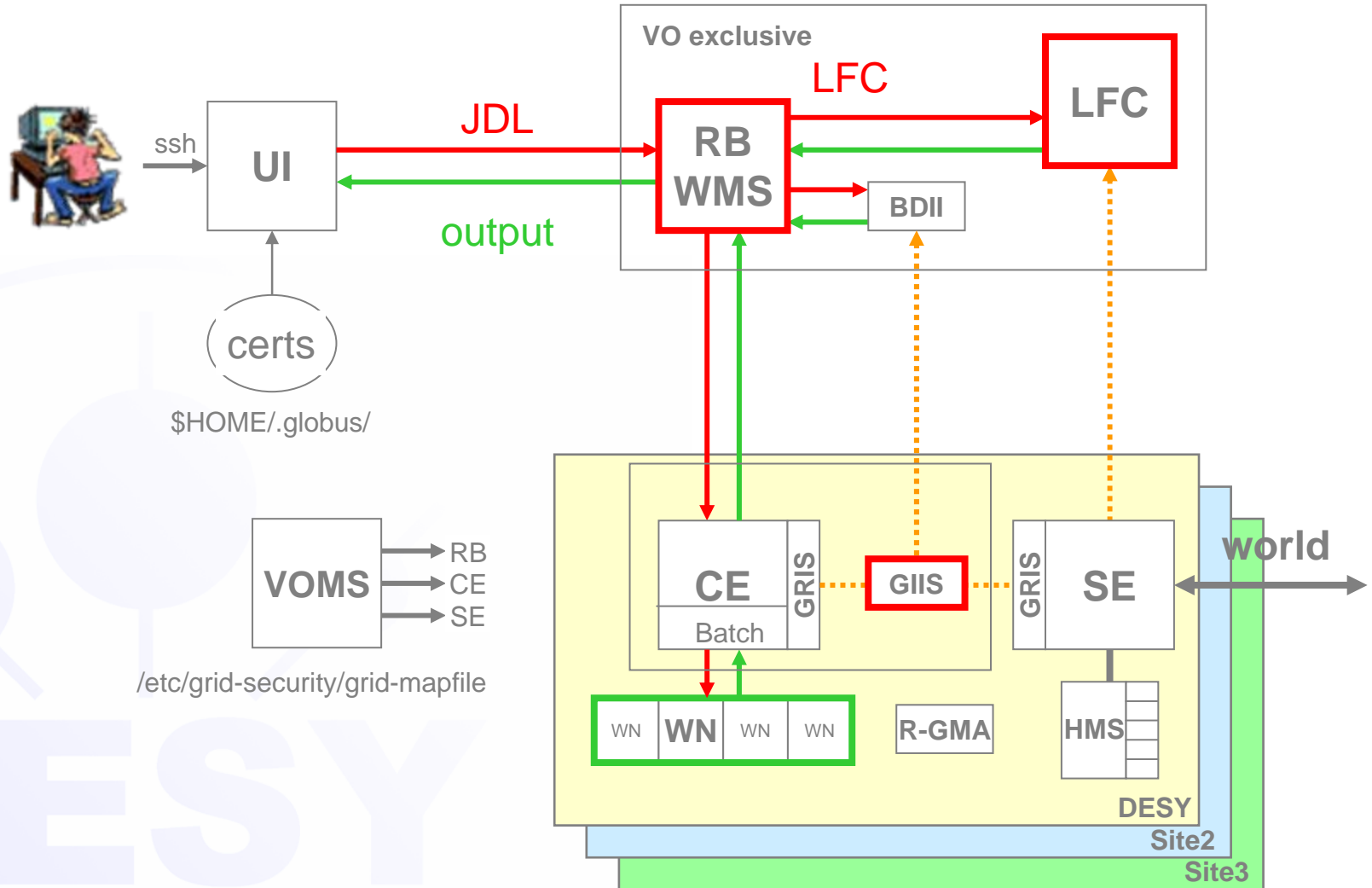

▪ **Grid@DESY/HH**

- **~580 CPU cores (~770kSpecInt), 900GB, ~250TB disk**
- **All cores on SL4, 32bit (grid-ce3, grid-batch3)**
- **Several dCache SE, 1 dedicated for CMS (default SE), 1 for Atlas**
- **~30 boxes, core services - steering/management (RB(4), WMS, VOMS, LFC, ...)**

▪ **Grid@DESY/ZN**

- **180 CPU cores (~280kSpecInt)**
- **100 cores on SL3, 32bit, 80 cores on SL4, 64bit**
- **~45TB disk dCache SE**

Counts , Developments, Limits (2)



HAMBURG · ZEUTHEN

- **networking - wide area**
 - **1 Gb/s connectivity to XWIN officially**
 - **10 Gb/s in place (XWIN)**
 - **10 Gb/s VPN to Zeuthen**
- **pool accounts as deployed by yaim and EGEE**
(special treatment for CMS software deployment needed?)
- **2GB/core RAM, 5GB/job disk**
- **VO user support by CMS**



DESY T2 Usage 2007



HAMBURG · ZEUTHEN

Wallclock time HH+ZN

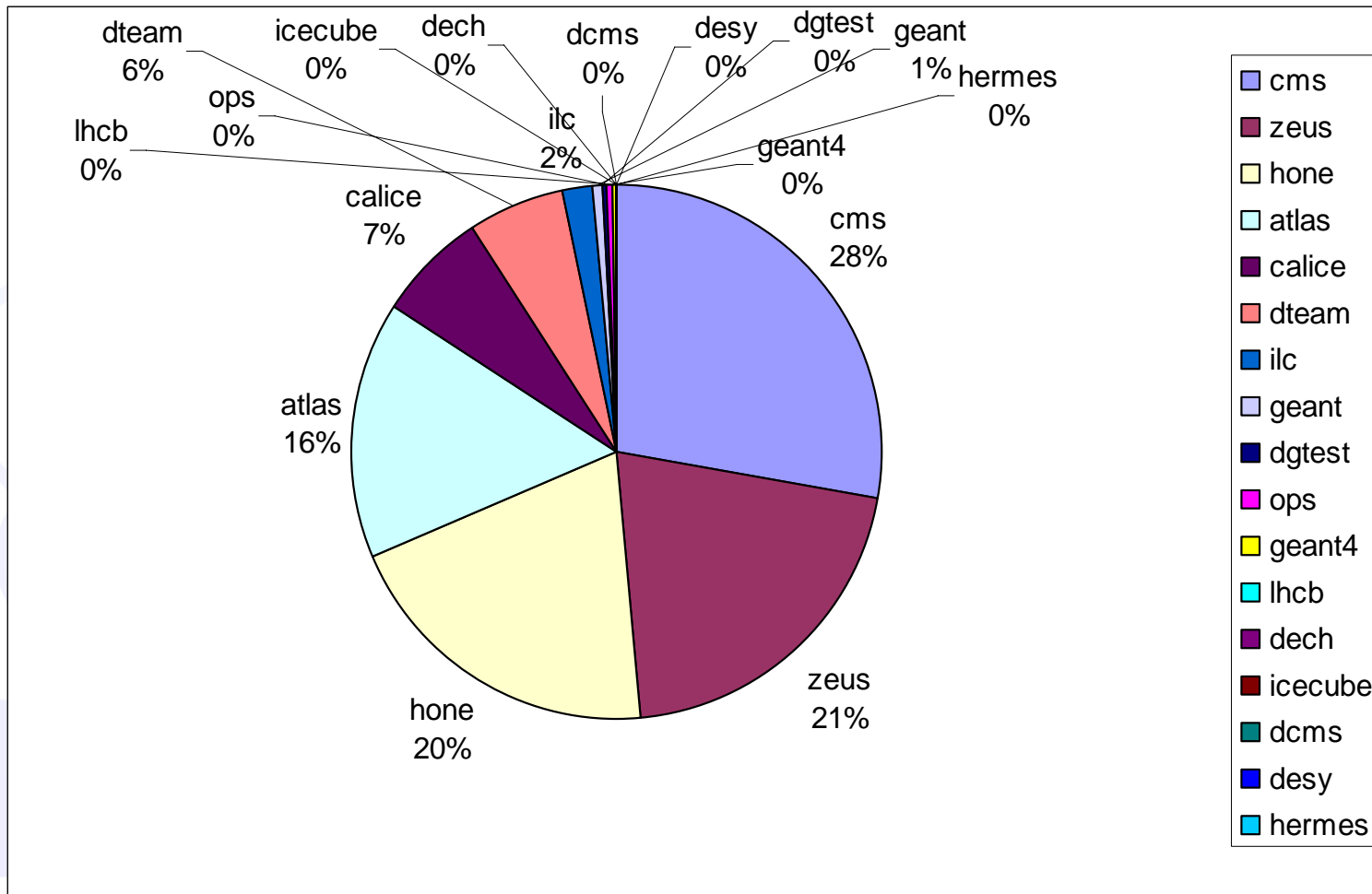

DESY T2 Usage 2007



HAMBURG · ZEUTHEN

CPU time HH+ZN

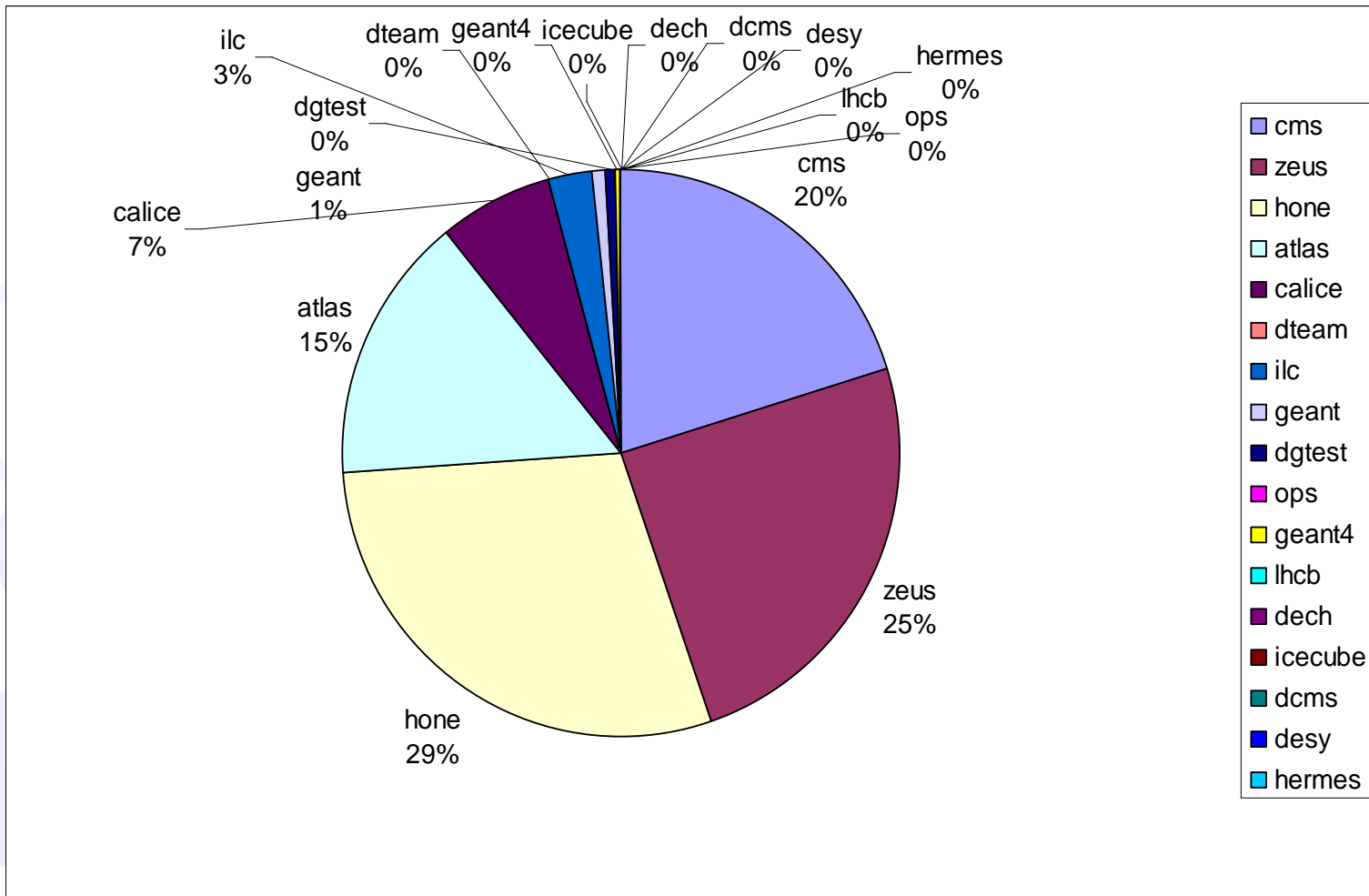

DESY T2 Usage 2007



HAMBURG · ZEUTHEN

Wallclock/CPU time (h) HH+ZN

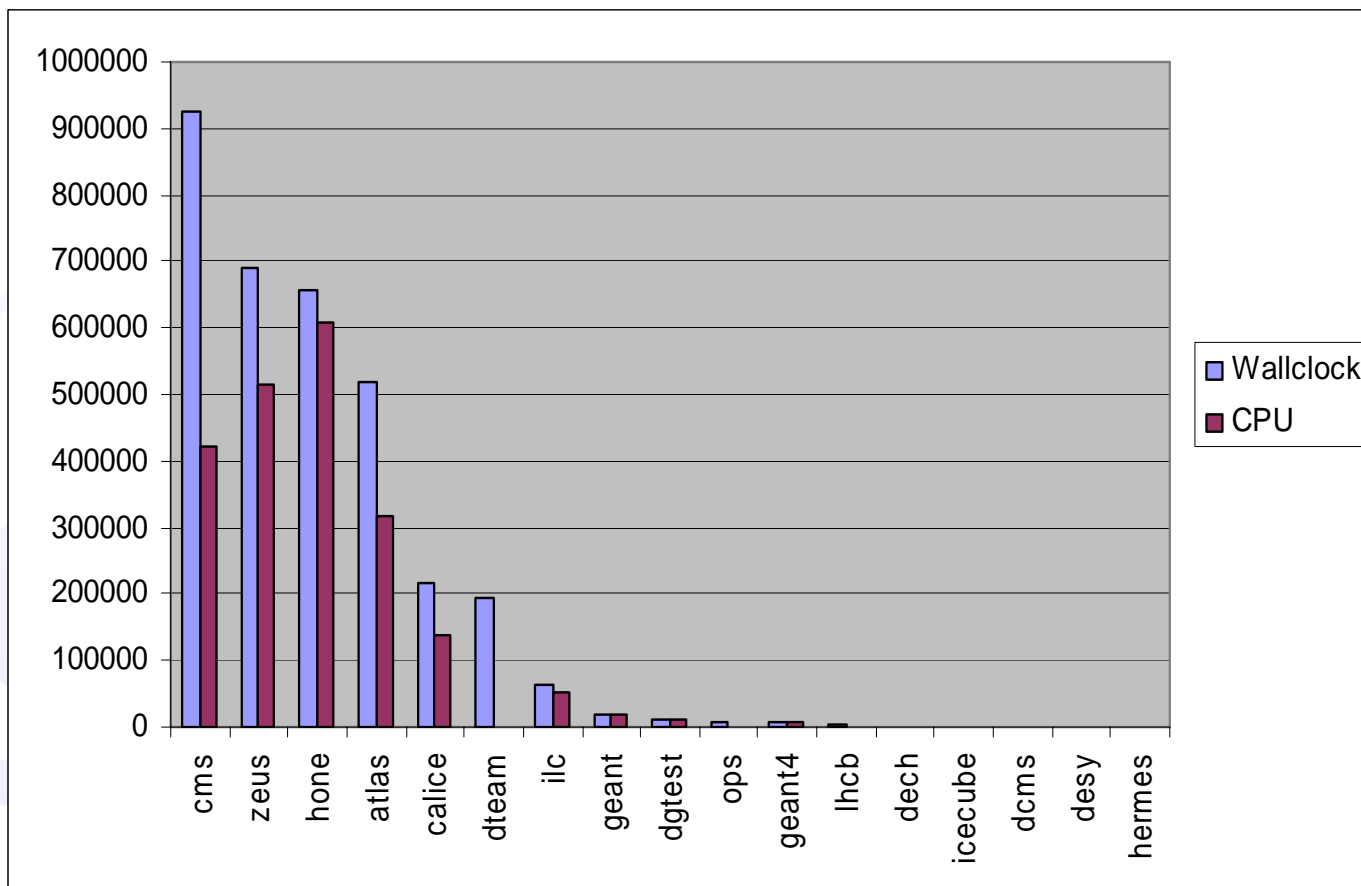

ATLAS/CMS: Relative high I/O fraction



DESY T2 Usage 2007



HAMBURG · ZEUTHEN

Total Wallclock/CPU time (days) HERA vs LHC

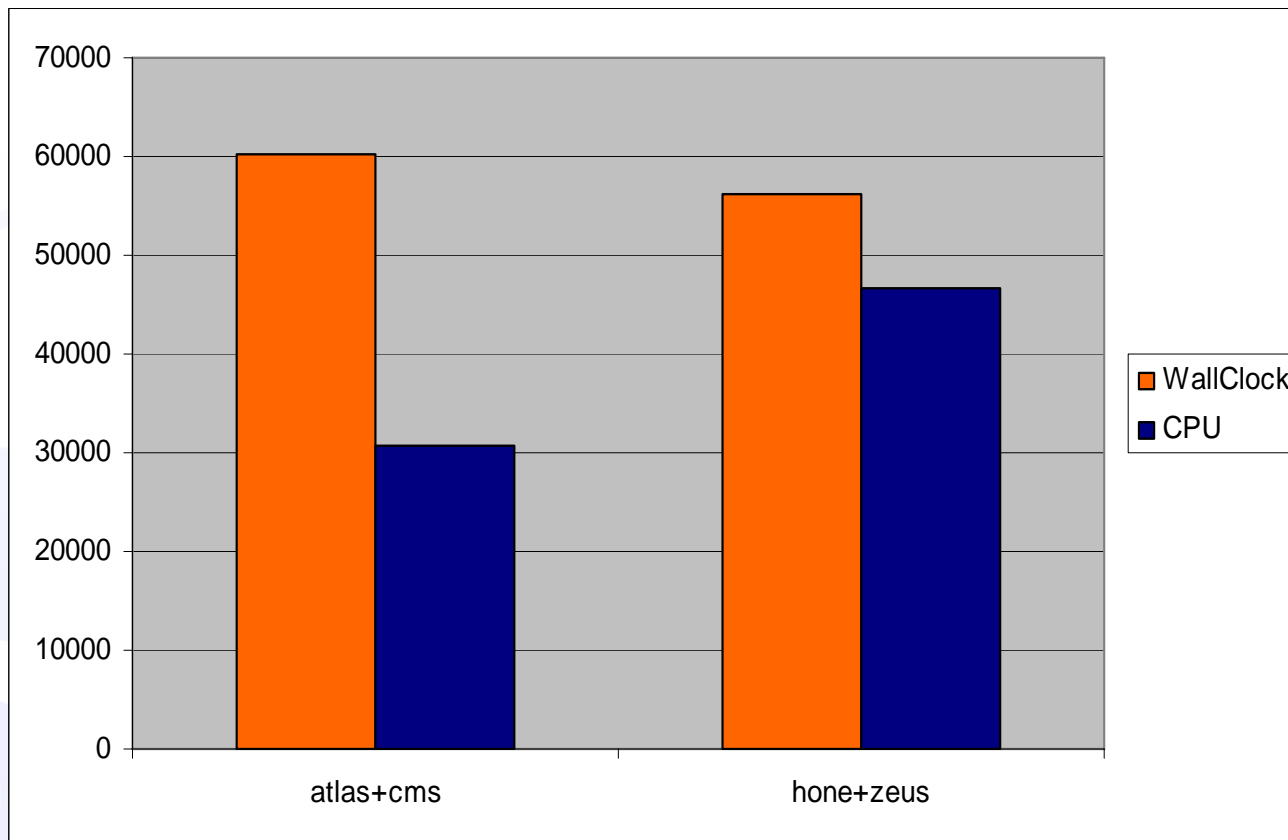

DESY T2 Usage 2007



HAMBURG · ZEUTHEN

Wallclock time ZN

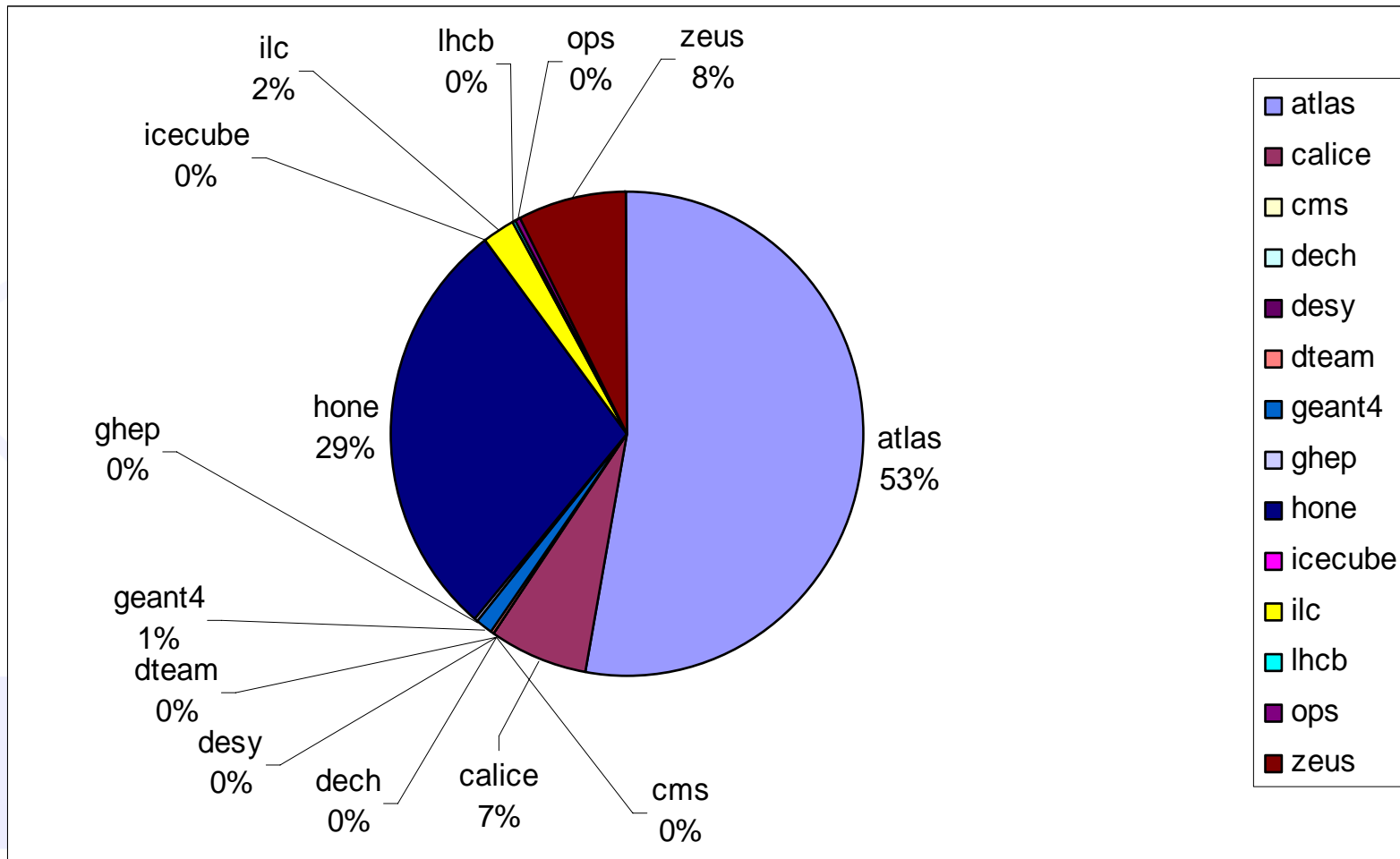

DESY T2 Usage 2007



HAMBURG · ZEUTHEN

CPU time ZN

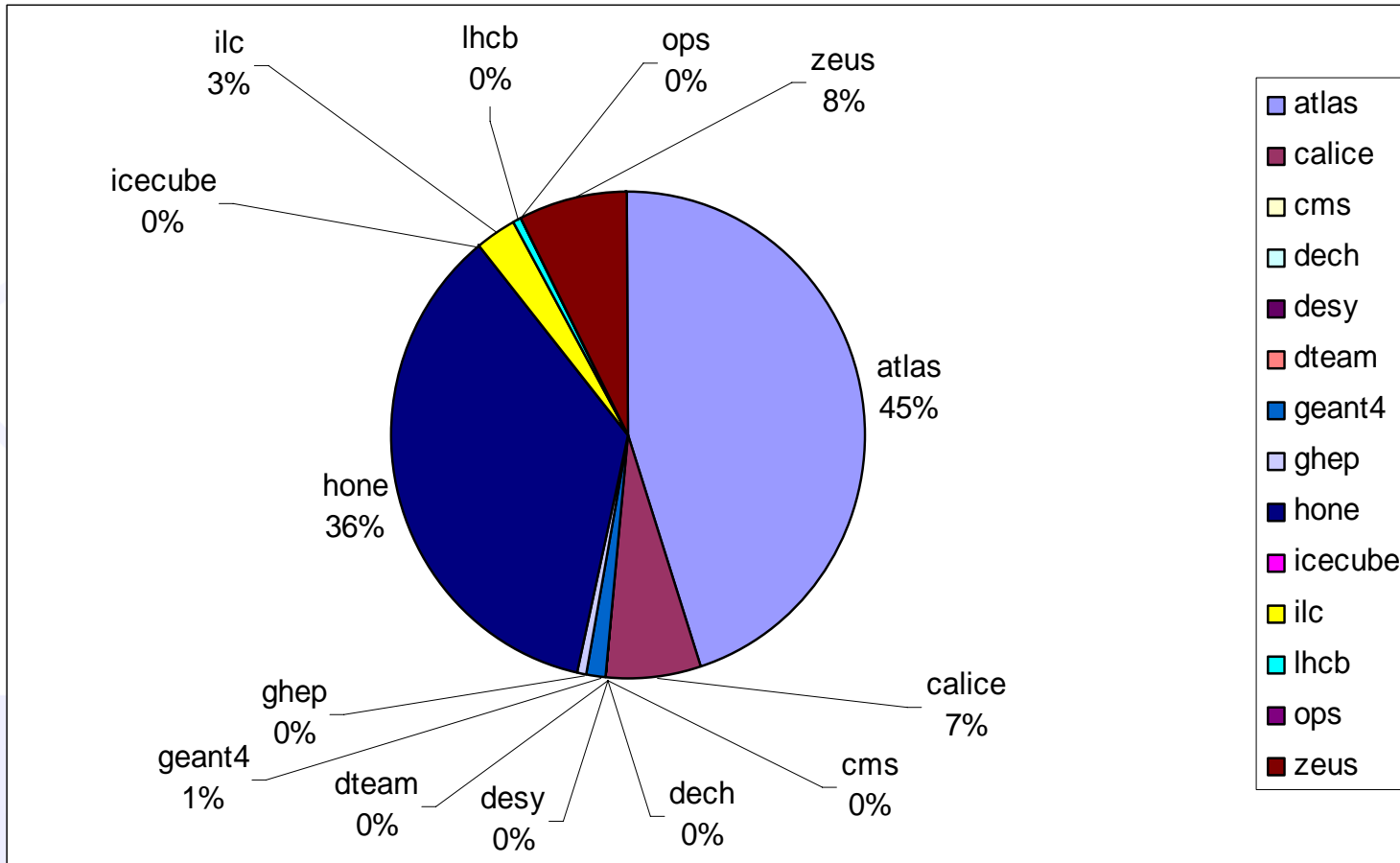

CMS VO
Supported (!)



Overview National Analysis Facility (NAF) architecture (simplified)



HAMBURG · ZEUTHEN

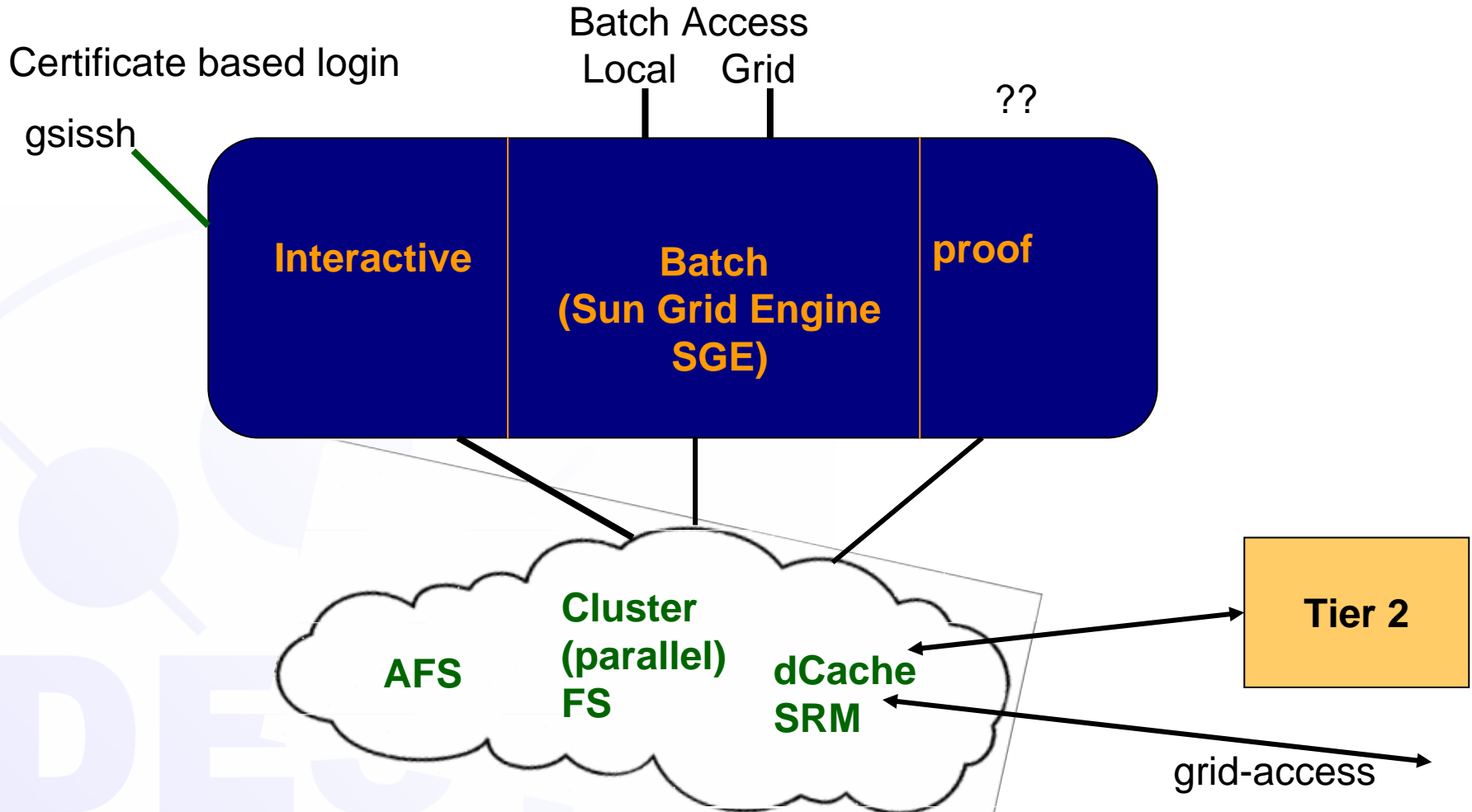

Overview NAF (2)



HAMBURG · ZEUTHEN

Distributed at DESY Zeuthen and Hamburg for users from german institutes from CMS, Atlas, LHCb and ILC.

Hardware Computing:



same blades to keep number flexible

1. order: blades with several hundred cores, 2GB/core, 2*150GB disk/blade, Infiniband

Hardware

Storage: probably SUN thumpers (17.5TB/box at raid 6)
for dCache pools, for afs home and group space, high-performance I/O

Back-up: more user input needed



NAF Worker Node Architecture



HAMBURG · ZEUTHEN

CPUs – today Quad-Core Intel CPUs 5435 („Clovertown“),
if appropriate Dual-Core (5160 “Woodcrest”)

Per **core**

- 2 GB main memory
- 20 GB disk
- 20 MB/s bandwidth for I/O applications (PROOF - 100 MB/s ?)
- n(?) MB/s bandwidth for disk I/O

LO Management incl. digital KVM,
IPMI – at the minimum, service processor, interface for automatic upgrades,
diagnostics...

RedHat certified

redundant power supply (not clear whether necessary)

good **performance/Watt** ratio

Service Level: 3-years **On-side service** NBD

Format: **Blade**



NAF: Org., Plans, Schedule



HAMBURG · ZEUTHEN

Def. of work packages, each WP with 3-5 people and a convener

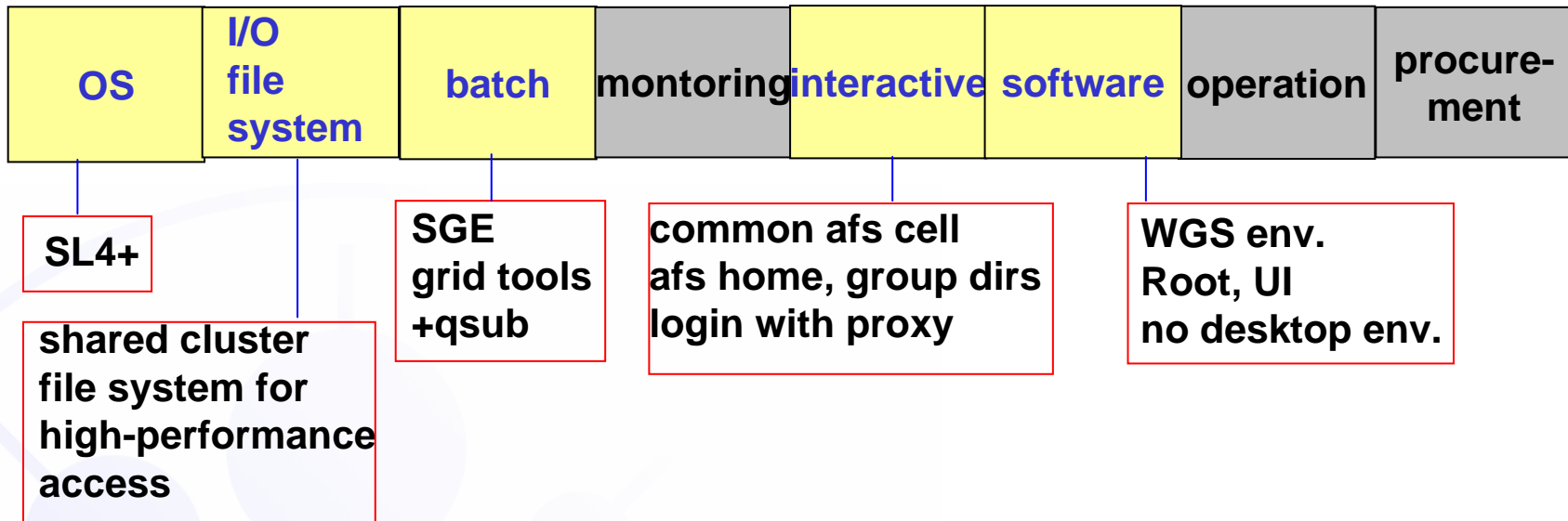

Soon (October?) meeting with users from all groups to review the plans.

Pilot system should be ready to use end of November (Helmholtz Alliance kick-off meeting Dec 3rd-5th)

Finances: Helmholtz Alliance and DGrid Sonderinvestition





Summary

- Grid Infrastructure and T2
 - in good shape and ready for ramp up
 - heavily in use by several VOs
 - shows good performance in CMS tests
(thanks to UniHH T2 monitoring shift team)
- National Analysis Facility in preparation
 - many open questions, items
 - user feedback meeting soon

DESY



Back-up



HAMBURG · ZEUTHEN



Revised hardware resources plan

(C=CTDR, N=New) for a average CMS Tier 2

(Ass.: 25 Tier 2's)



HAMBURG · ZEUTHEN

	2007	2008	2009	2010
CPU [kSI2k]	300 N 400 C	600 N 900 C	1000 N 1400 C	1810 N 2300 C
Disk [TB]	50 N 100 C	170 N 200 C	340 N 400 C	530 N 700 C
Tape [TB] (?)				



Revised hardware resources plan

ramp up (total for DESY)



HAMBURG · ZEUTHEN

	2007	2008	2009	2010
CPU [kSI2k]	380	1500	2300	4000
Disk [TB]	150	460	840	1440
Tape [TB] (?)				

