

Status of efforts to develop the next generation infrastructure for cavity processes (with industrial participation)

Shekhar Mishra

Fermilab

Goals for SRF Infrastructure



- To perfect U.S. fabrication & processing of SRF cavities and modules and to demonstrate performance with a full range of testing
 - Deploy ILC design / processing / assembly techniques
 - Establish process controls to reliably achieve high gradient cavity operation and module performance
 - Test cavities and cryomodules at the component level and in a systems test to demonstrate yield, reproducibility and beam performance
- Facilitate commercial production of SRF components and modules
 - Train and transfer SRF technology to the US industry
 - Allow industrial participation and input to the process
- Participate in SRF Research and Development
 - Develop expertise in SRF technology and provide training base for construction and operation of future accelerators
 - Our attempt to fit into the world's SRF community
- All of this work will be carried out with US/international collaboration
- **US and Fermilab to be a**
 - **“Credible” and “Qualified Host” of ILC**

Present: US SRF Infrastructure



- **Limited cavity fabrication capability in US industry**
 - One US company (AES) fabricating SRF cavity
 - Developing two new companies (Niowave and Roark)
 - European Industry much advanced in ILC cavity fabrication
- **Cavity Processing and Vertical Testing R&D Facility**
 - Jlab (~30 FY07, ~40 FY08, ~50 FY09) cycles/yr
 - ANL/FNAL (~50 FY08, ~60 FY09) cycles/yr
 - Cornell ~12 cycles/yr
 - VTS @FNAL ~50 cycles/yr (late FY07)
 - Significant fraction of this capacity is used to support R&D Program
 - Process development
 - Single cell Processing
- **Horizontal Test Stand**
 - FNAL ~24 cavities/yr
- **Cavity Dressing and Cryomodule Assembly**
 - FNAL 2-4/yr (FY07)

Cavity and Cryomodule

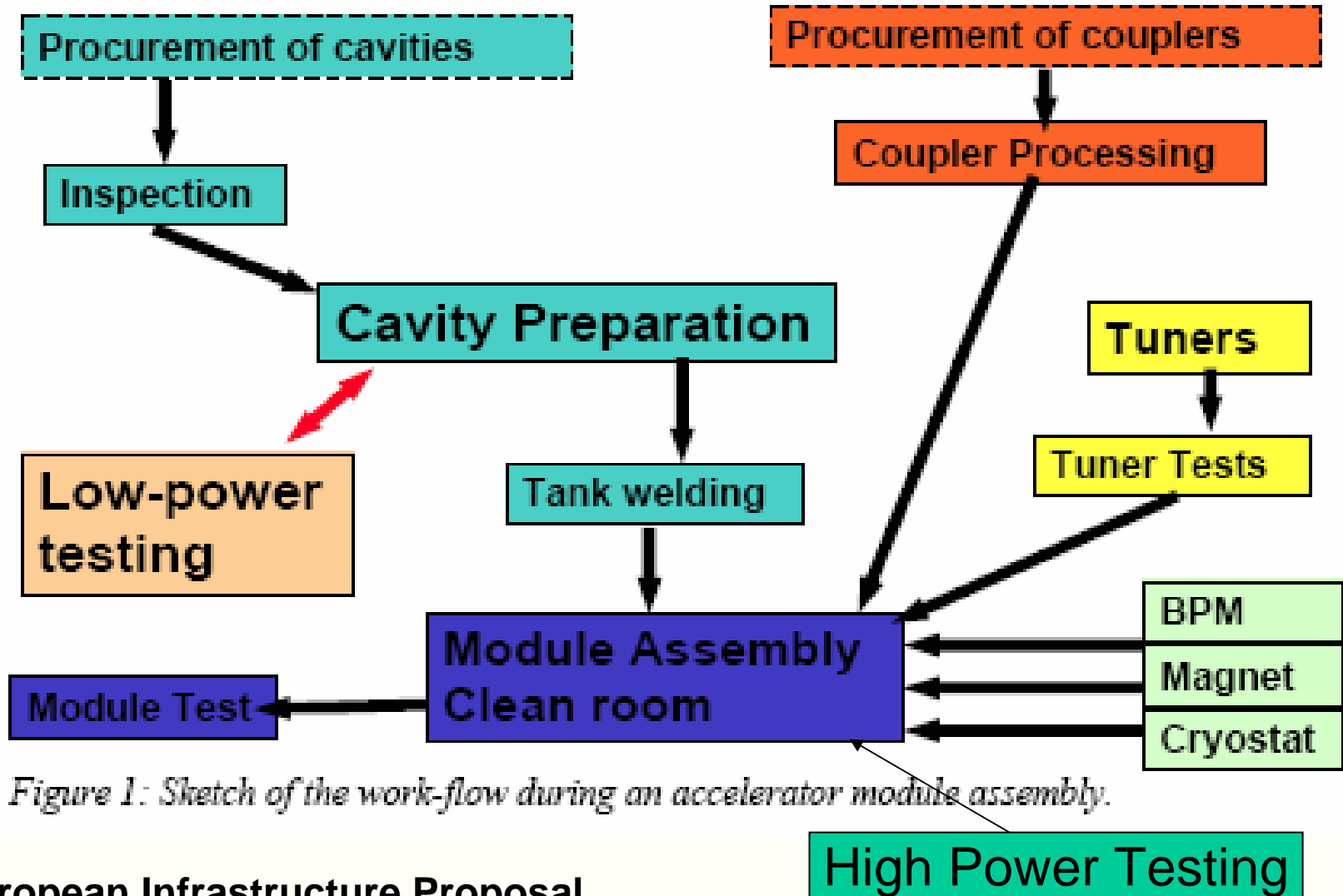

Figure 1: Sketch of the work-flow during an accelerator module assembly.

Infrastructure for Cavity and Cryomodule Fabrication, Testing



- **Bare cavity production**
 - Niobium QC
 - Fabrication facilities (e.g. Electron beam welders)
 - Buffered Chemical Polish facilities (BCP) for cavity parts pre-welding
- **Pre-Production Cavity Processing**
 - Tuning for field flatness
 - Surface Processing (Tumbling, BCP and Electro Polishing)
 - Ultra clean H₂O & High Pressure Rinse systems
 - Furnace for 600 – 800 C bake (removal of H)
- **Vertical Test facilities (Cryogenics + low power RF)**
- **Cavity Dressing Facilities (cryostat, tuner, coupler)**
 - Class-10/100 clean room
- **Horizontal cavity test & Coupler test facilities (RF pulsed power)**
- **String Assembly Facilities**
 - Large class-100 clean rooms, Large module assembly fixtures
 - Class-10 enclosures for cavity inner connects

US Program (ILC-ART & OPR)



Cavity and Cryomodule Production

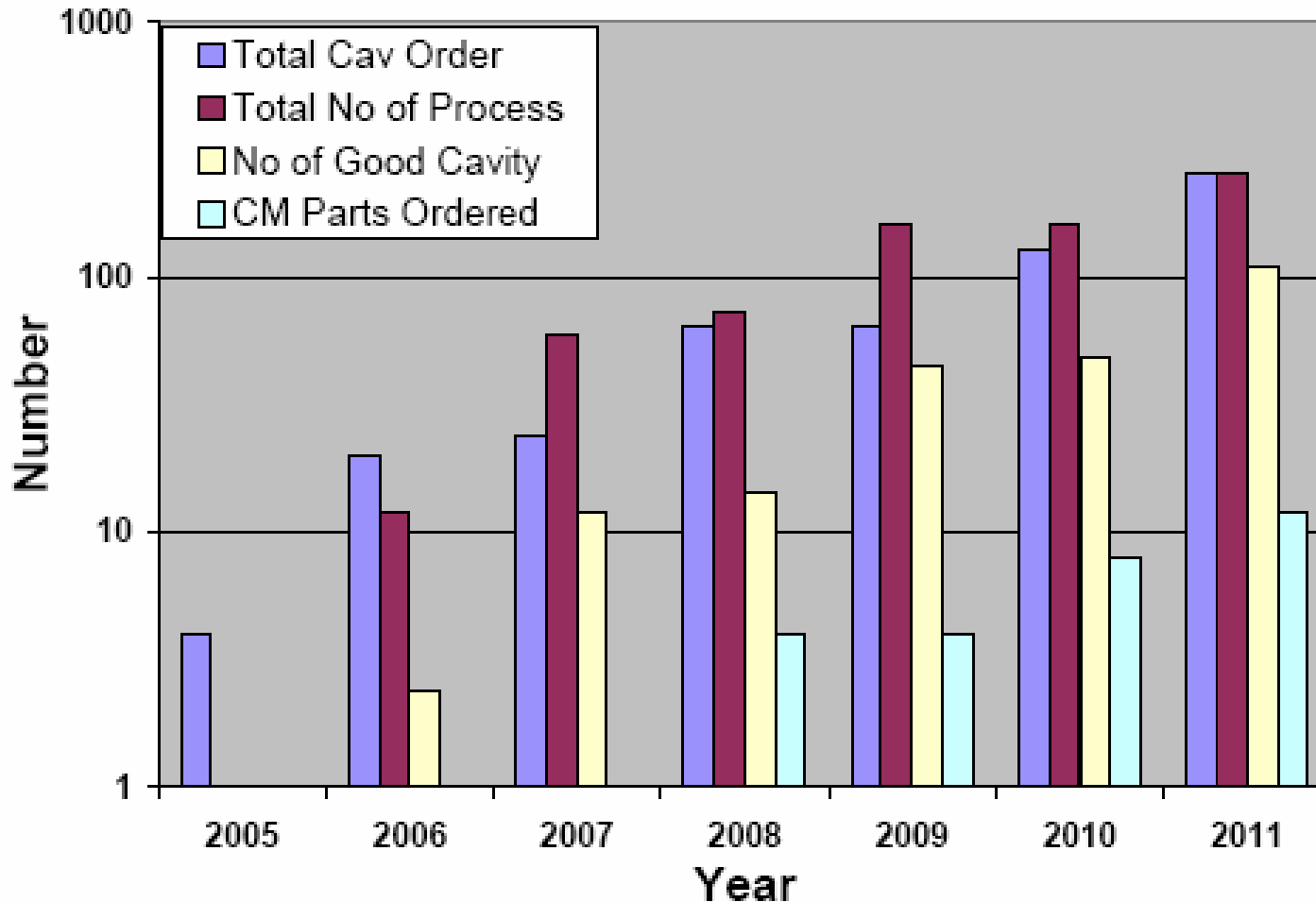

Scope: US Laboratories Capacity



Program	FY07	FY08	FY09	FY10	Capacity Needed/yr by FY10
Cavity Processing (EP, HPR, Bake) Cycles/yr	Jlab-30 Cornell-10	Jlab-40 Cornell-10 ANL-40	Jlab-40 Cornell-10 ANL-40 Fermilab-20	Jlab-40 Cornell-10 ANL-40 Fermilab-100	200
Vertical Testing	Jlab-30 Cornell-10 Fermilab-20	Jlab-40 Cornell-10 Fermilab-75	Jlab-40 Cornell-10 Fermilab-75	Jlab-40 Cornell-10 Fermilab-200	200
Horizontal Testing	Fermilab-6	Fermilab-24	Fermilab-24	Fermilab-72	72
Cryomodule Assembly	Fermilab-1	Fermilab-4	Fermilab-8	Fermilab-12	12
Cryomodule Test	Fermilab: ILCTA_NML	Fermilab: ILCTA_NML	Fermilab: ILCTA_NML	Fermilab: ILCTA_NML CMTS	12

Scope: Fermilab SRF Infrastructure



- **Cavity Fabrication**
 - **Increased cavity fabrication R&D and training US industry**
 - **Electron Beam Welder**
 - **Eddy Current Scanner**
 - **Automated Cavity Tuning**
 - **100+ Cavity/yr (by FY09)**
- **Cavity Processing Facility (Pre-Production Facility, existing technology with industry, modular and redundancy)**
 - **100+ Cycles/yr (by FY09)**
- **Vertical Testing**
 - **Additional 100+ Cavity/yr (by FY09)**
- **Horizontal Test Stand**
 - **Additional 48 Test/yr (Maximum US Capacity needed)**
- **Cryomodule Assembly**
 - **1 per month**
- **Material R&D**

Development of Industry



Cryomodule Process	Starts with	Transitions to
Cavity Fabrication	Lab/Industry Collaboration	Industry
Cavity Processing	Lab/Industry Collaboration	Industry
Low Power Test (VTS)	Laboratory	Laboratory
Cavity Dressing	Lab/Industry Collaboration	Industry
High Power Test (HTS)	Laboratory	Laboratory
Cryomodule Fabrication	Lab/Industry Collaboration	Industry
Cryomodule Test (CTS)	Laboratory	Laboratory

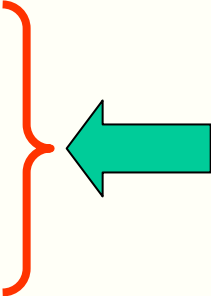

The technology for cavity fabrication & processing, cavity dressing and cryomodule fabrication will be transferred to Industry.

Cryogenic testing of cavities and cryomodules along with beam tests will remain the responsibility of US laboratories.

- **The proposed infrastructure will improve over the existing infrastructures**
 - **Present infrastructures are single-line processing R&D infrastructure**
 - Failure in one process chain leads to unacceptable delay in schedule
 - **New Infrastructure will have**
 - All cavity processing under one clean environment
 - Redundancy in layout
 - Modularized for maintainability and flexibility
 - Flexibility: Implementing change in the overall production scheme
 - Quality Assurance and control process
 - Available for use for other projects

Model: Processing and Testing Infrastructure



- Degrease & EP 80 um (3 days)
- HPR 1 day
- Drying 1 day
- H-removal, 600 – 800 C (3 days)
- Tune field flat (1 day)
- EP 10 um (1 day)
- HPR (1 day)
- dry (1 day)
- First stage assembly & HPR (1 day)
- Dry 1 day
- Final assembly to bake stand, evacuation (1 day)
- 120 C on bake stand (2 days)
- Assembly to test stand (1 day)
- Cold test, warm up (3 days)

Total 21 days (4 weeks)

Test set-up has maximum 4-day, rate limiting time

- Assume one set-up each per facility
- Max cycles = 5 per month (20 days) = 60 per year
- Down time and maintenance time may reduce this
- Calculation Estimates: 50 per year max
- Jlab estimates : 40/year

A R&D Model Cavity Processing

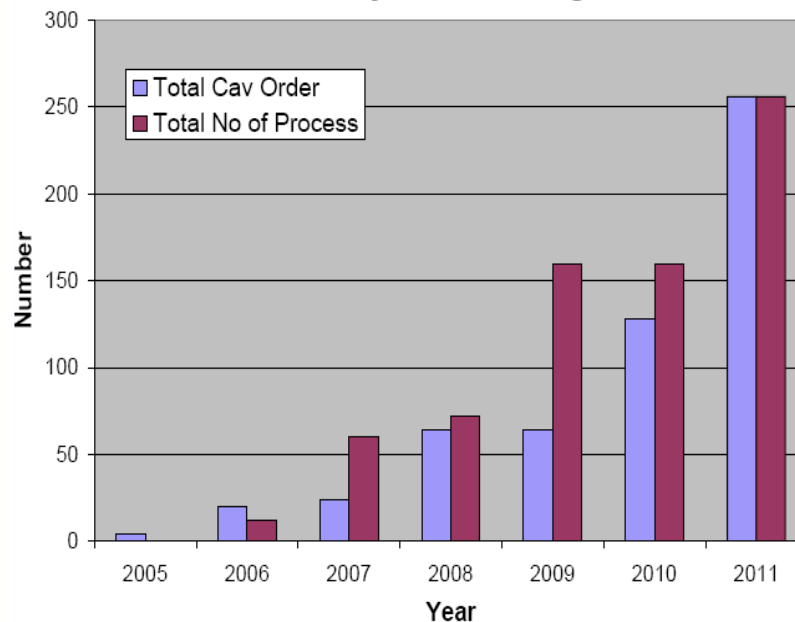

As defined by ILC-ART & OPR

Schematic of Cavity Processing Facility



Each EP, HPR .. System can do ~40 cy/yr



- EP Systems: 2 (1 Spare)
- HPR Systems: 2 (1 Spare)
- BCP Systems: 1 (1 S)
- Vacuum Furnaces: 2
- Low Temp Furnaces: 2
- Cavity Tuning: 1
- Tumbling: 1
- Clean Rooms

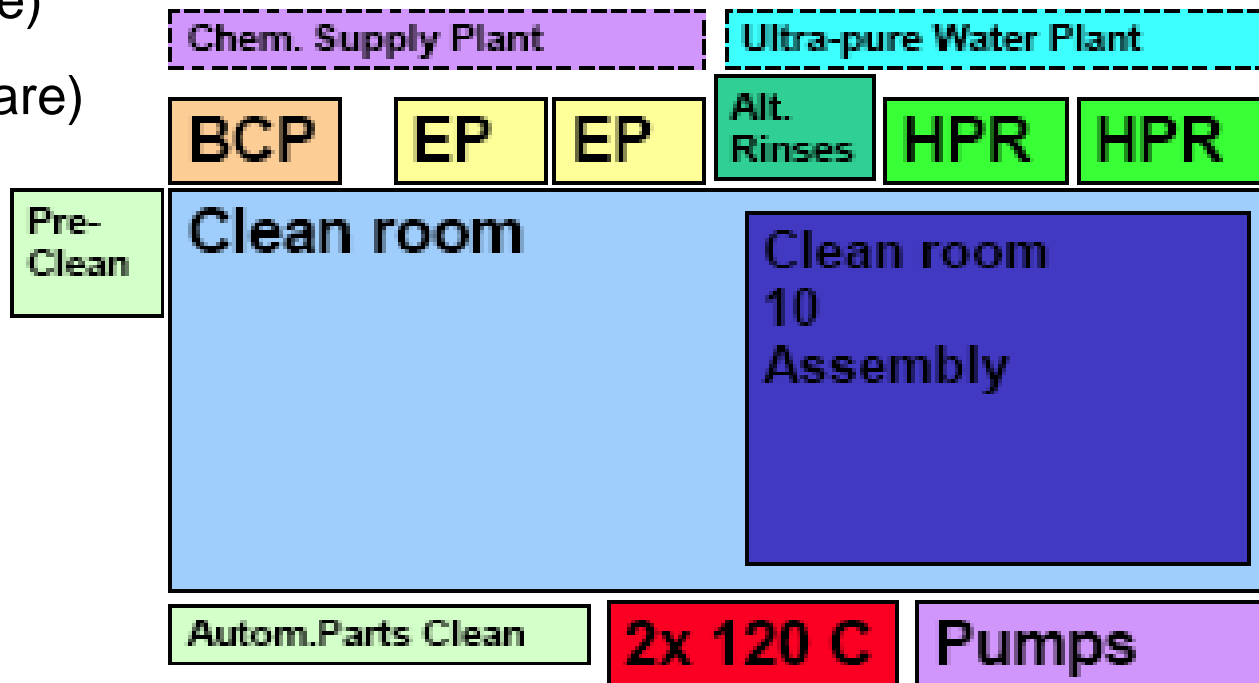
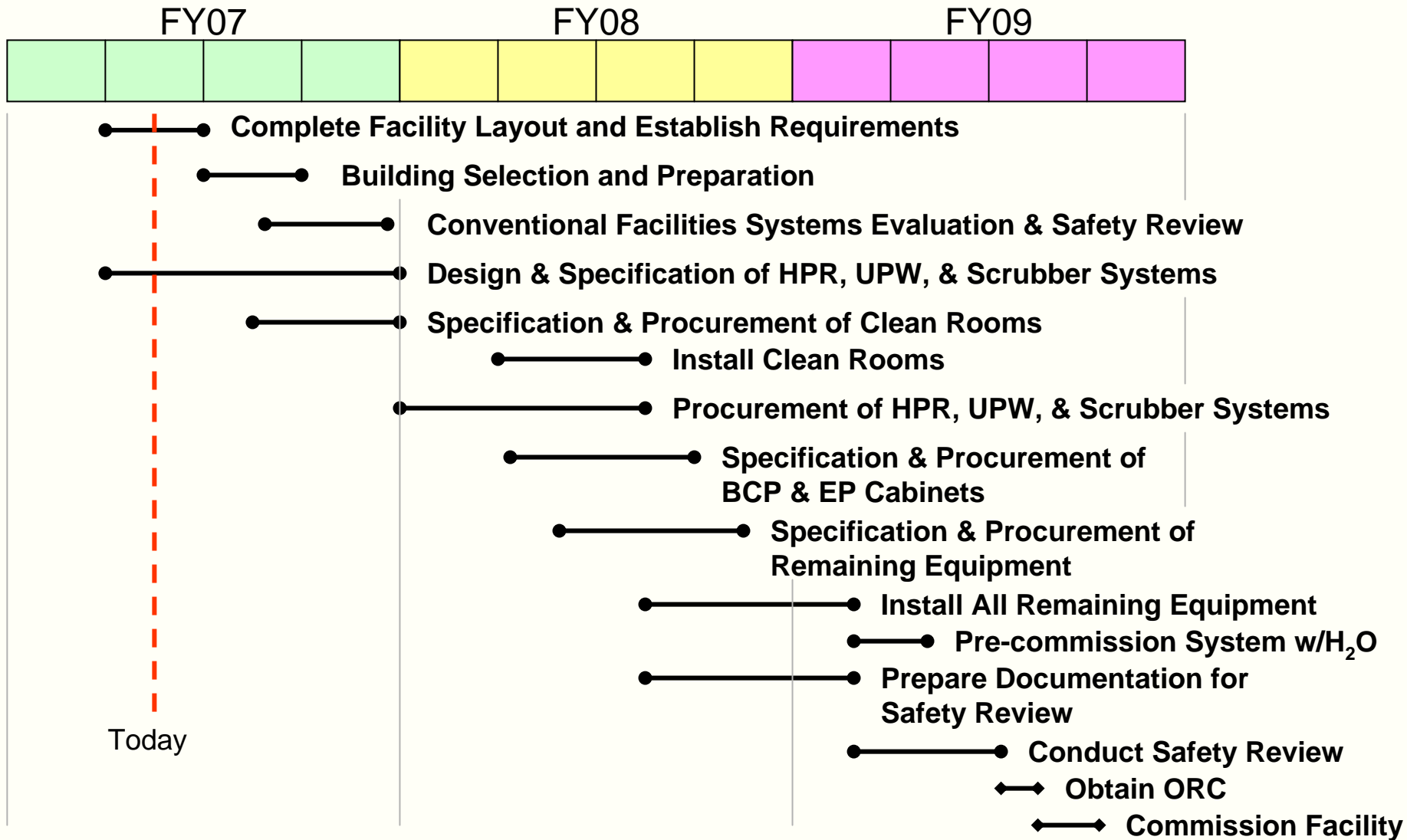

Figure 2: Sketch of the cavity preparation infrastructure.

European Infrastructure Proposal

CPF Schedule Timeline



Alternative: An Off-Site CPF



- A contract could be written for the design, construction, and operation of an off-site facility located very near FNAL.
- Facility would be financed by ILC funds and owned by government, but operated by industry
- Advantages:
 - Operation by an experienced electropolishing industrial firm using their manpower
 - Significantly reduces the need for large quantities of nasty chemicals on FNAL site
 - Initiates the industrialization program cavity processing
- Unknown total cost, estimate

Off-Site CPF Scope of Work



- Perform initial cavity inspection
- Perform bulk chemistry operations
 - Internal 80u EP
 - External 20u BCP
- Possibly include HPR; otherwise, ship cavity to FNAL in container filled with UPW

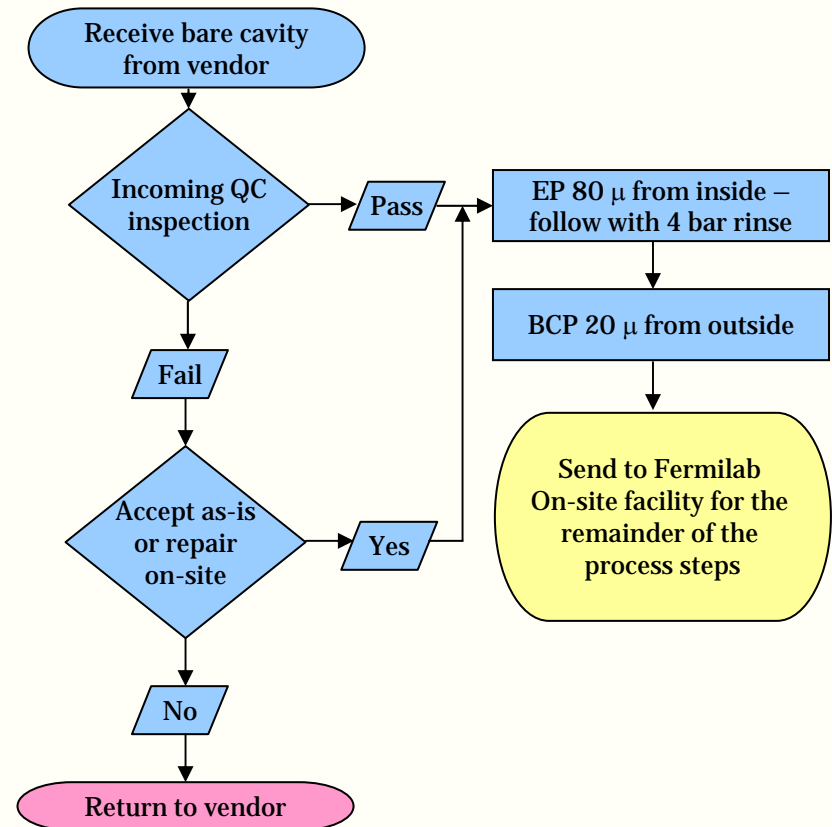

Present: Vertical Test Facility-1

- A Vertical Test Stand is under Construction at Fermilab (IB1)
 - Existing Cryogenic plant in IB1 has the capacity of 125 W at 2 K (250 W available for intermittent test)
 - Test Stand will be capable of testing ~50 Cavities/yr
 - Commissioning late summer 07

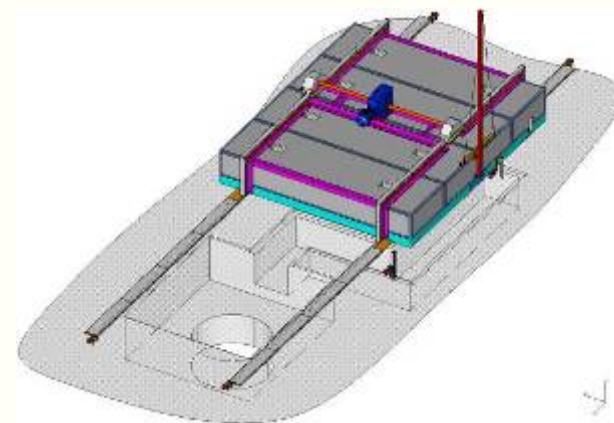
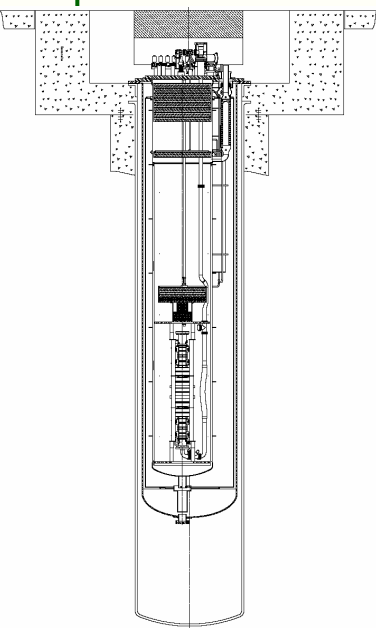

Proposed: Vertical Test Stand 2 & 3



- To increase the capacity of the VTS
 - Upgrade the VTS-1 for 2 cavity operation (~75 cy/yr)
 - Add 2 more VTS pits (VTS-2 and VTS-3) (~200 cy/yr)
 - Upgrade the cryogenic infrastructure (decouple from superconducting Magnet test)
 - Upgrade the cavity staging area
- To support cavity R&D: Field emission studies and Quench Location

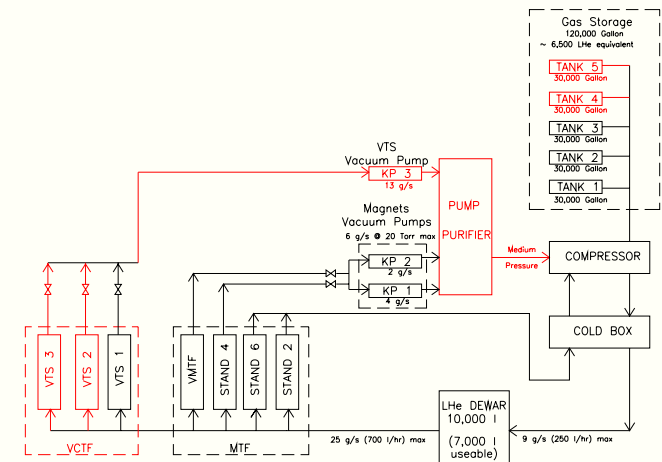
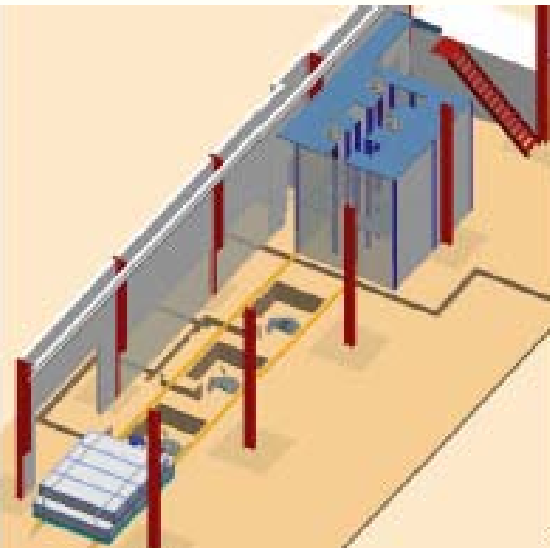

Vertical Test Stand 2 & 3

Present: Horizontal Test Stand - 1

- Horizontal Test Stand -1 is getting ready for commissioning at Meson.
 - The maximum capacity of this test stand is ~24 cavities/yr
- It will be debugged with a cavity from DESY in early spring.
 - This cavity is getting prepared by Jlab.
- The commissioning of the HTS will happen with AC7 (9-cell, 41 MV/m) cavity.
 - Coupler from DESY
 - Tuner and He Vessel from INFN to Penn, Getting commissioned at Penn
 - Will be dressed at Jlab



Cavity Testing Infrastructure

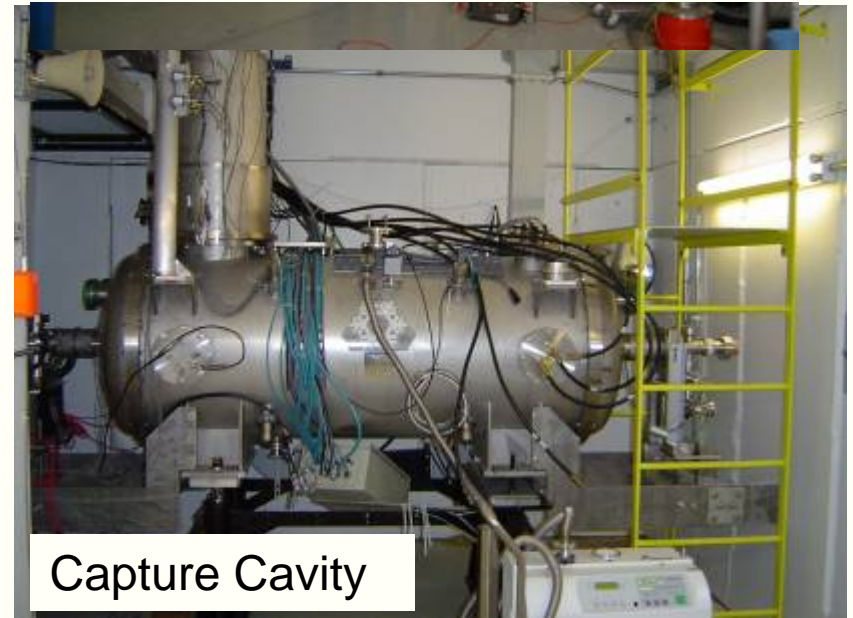
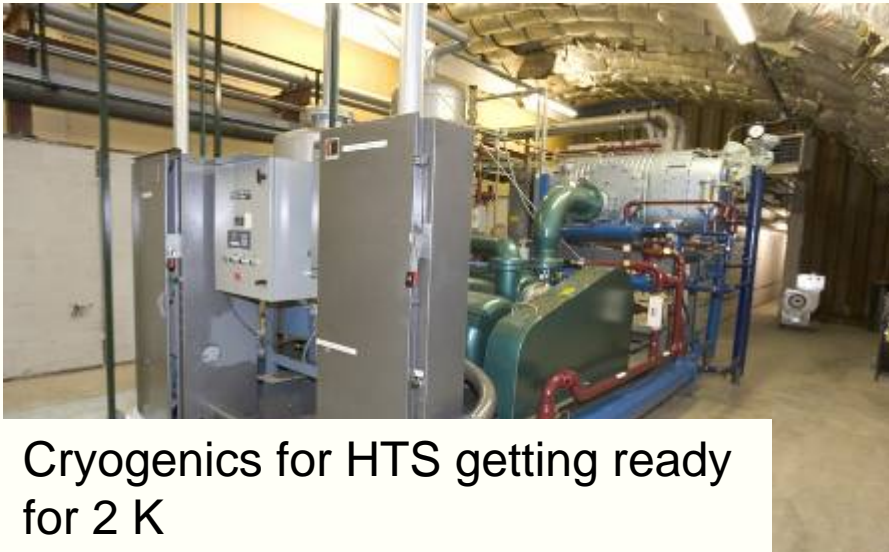
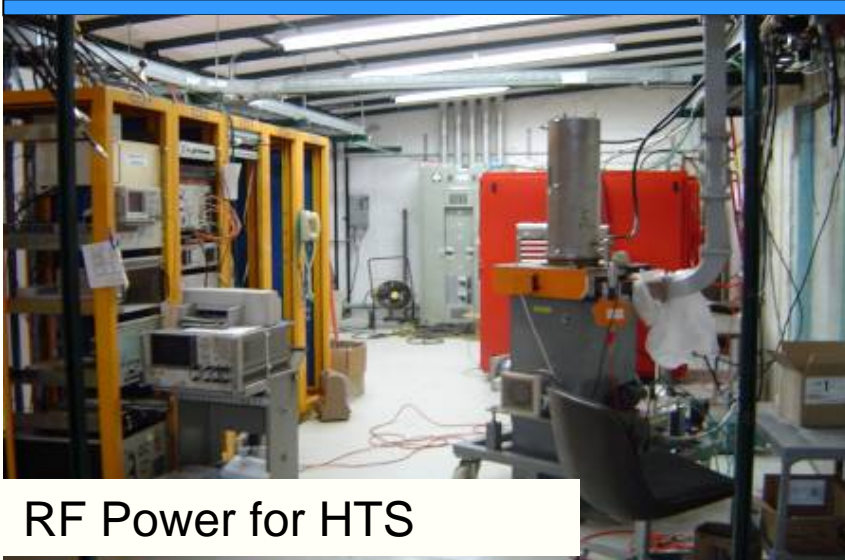

Summary



- **The Main Linac Cavity and Cryomodule R&D program and Infrastructure development**
 - **Impact and contribute toward the critical ILC R&D**
 - **Build a minimal facility at Fermilab**
 - **Train people in SRF at Fermilab**
- **Get the US industry involved from the initial phases**